

# INSTALLATION MANUAL FOR VOLKSWAGEN T5 AIRTRONIC D2



# IMPORTANT INFORMATION

While every care has been taken to ensure its accuracy, all information contained in this document should only be used in conjunction with the relevant Technical Description Manual which is provided on the CD supplied with every Airtronic heater.

It is the responsibility of the installing engineer to ensure that the system can be installed in accordance to the safety instructions contained within the Technical Description Manual.

Eberspächer (UK) cannot be held responsible for variation in information contrary to this guide, whether it is due to vehicle manufacture or custom design.

if indoubt please contact the local dealer for assistance.

For the current dealer list please go to: [www.eberspacher.com](http://www.eberspacher.com)



**AIRTRONIC / AIRTRONIC M**  
Technical description, installation,  
operation and maintenance instructions.



AIRTRONIC		AIRTRONIC M	
	Order no.		Order no.
AIRTRONIC 02, 12 V	25 2069 05 00 00	AIRTRONIC 03, 12 V	25 2317 10 00 00
AIRTRONIC 03, 24 V	25 3070 05 00 00	AIRTRONIC 04, 12 V	25 1912 05 00 00
<b>Complete package</b>		AIRTRONIC 04, 12 V	25 2113 05 00 00
AIRTRONIC 03, 12 V	25 2115 05 00 00	AIRTRONIC 04, 24 V	25 2144 05 00 00
AIRTRONIC 03, 24 V	25 2116 05 00 00		
		AIRTRONIC 04 Plus, 12 V	25 2484 05 00 00
		AIRTRONIC 04 Plus, 24 V	25 2488 05 00 00

**Air heater for diesel and petrol**  
operating independently of the engine.



**Eberspächer**  
A world of comfort

25 2000 00 00 00  
40000

# INSTALLATION INSTRUCTIONS



1. Remove the driver seat in order to gain access to the vehicle floor and seat base.



2. Route the switch loom under the seat base in the cable track with vehicle loom. Continue to route to desired switch location.

Ensure that the loom is secured and protected from chaffing on sharp edges.

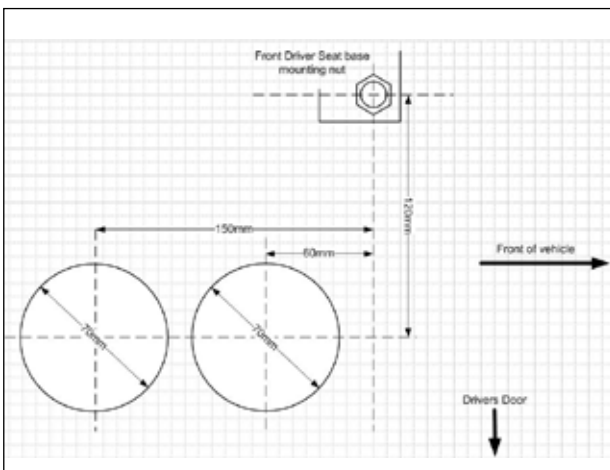

3. Drill 70mm holes for ducting through floor under seat base. Measurements shown are NOT TO SCALE.

 ENSURE AREA TO BE DRILLED IS CLEAR OF CABLES AND ANY OTHER COMPONENTS.



3a.

## INSTALLATION INSTRUCTIONS



4. Fit serial plate duplicate to driver side 'B' pillar as illustrated, this is to make the heater easily identifiable for servicing or repair work in the future.



5. Remove under body splash panels to gain access to fuel tank and the area where the heater will be fitted.



5a.



## INSTALLATION INSTRUCTIONS



6. Fit M6 Hexserts to pre-existing hexagonal holes as illustrated in Figure 6a. Point 1 and 2 will be for the heaters bracket mounting and Point 3 will be for combustion air pipe retaining clip. (Nutsert tool required).



6a.



7. Mount exhaust silencer to vehicle heat shield. Check flow direction of exhaust silencer is correct and take into account the routing of the exhaust pipe when positioning (Figure 7).



8. Fix heater to mounting plate, attach combustion air pipe and fuel line to the heater.

Secure combustion air pipe to the chassis using Hexsert fixing point 3 (Figure 6a), as fitted previously.

Ensure pipe is positioned so as to avoid ram air, do not position so it is facing the direction of travel.

Note: The combustion air pipe will be covered by vehicle splash guards when fitted.

# INSTALLATION INSTRUCTIONS



9. Cut the supplied ducting using a sharp knife to approximately 730mm and 890mm, then fit to heater using supplied clips and route to the 70mm holes in floor as illustrated in Figure 9.

Take care when bending the ducting so as not to kink or dent it, as any damage to the ducting can potentially cause the heater to overheat. Ensure that the heaters 'factor rating' is taken into account.

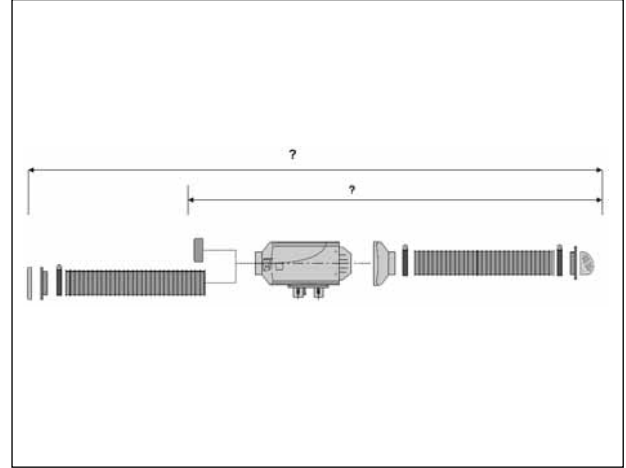

10. If more ducting is required then please ensure that the following information is taken into account:

Each heater has Factor Rating and each duct component bends in the ducting and the length of the ducting reduces this rating.

The calculation is worked out from the point of inlet to the first 'always open' outlet (Figure 10).

Item	Designation	Component rating
1	Protective grille	1.7
2	Connection piece 60 mm dia.	
3	Flex. pipe, 60 mm dia, 0.3 m long	0.3
4	Flex. pipe, 60 mm dia, 1.0 m long	1.0
5	Reduction hood 60 mm, straight	0
6	1 x 90° bends of flex. pipe	1.2
7	Swivel outlet	1.4
<b>Total of component ratings</b>		<b>5.6</b>

Rating sum = 5.6 does not exceed the heater rating 6.  
The installation is permissible.

10a. A D2 heater has a factor rating of '6' when using 60mm ducting, an example is shown in Figure 10b.

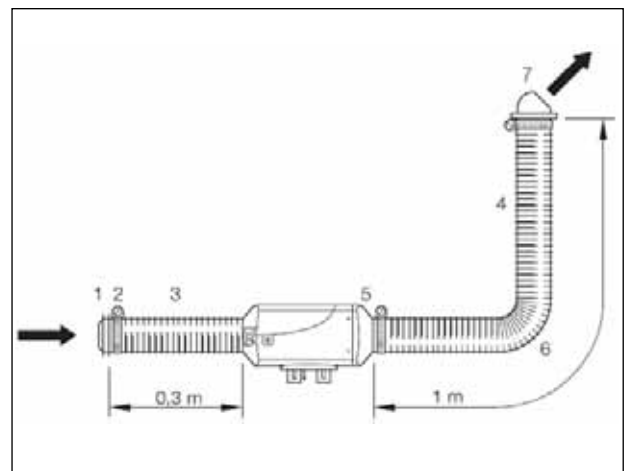

10b.

## INSTALLATION INSTRUCTIONS



11. Bend and cut exhaust to length, be aware of ducting and vehicle heat shields when routing exhaust pipe. Ensure exhaust does not come into contact with fuel line, looms, etc.

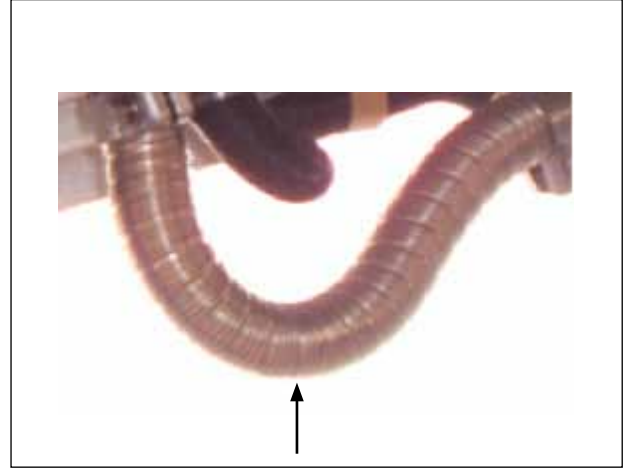

12. If required drill a 5mm drain hole at any low point of the exhaust, this will prevent any moisture build-up caused by condensation, potentially blocking the exhaust which would cause heater failure.



13.  CHECK FUEL LEVEL BEFORE DROPPING TANK, DRAIN IF NECESSARY AND SUPPORT TANK ADEQUATELY.  
Remove fixings from filler neck to allow the fuel tank to drop.



14. Loosen tank straps, removing middle strap before dropping tank to allow for tank support. Then drop fuel tank low enough to safely remove sender unit

## INSTALLATION INSTRUCTIONS



15. Unclip the fuel pipes and sender electrical connection.

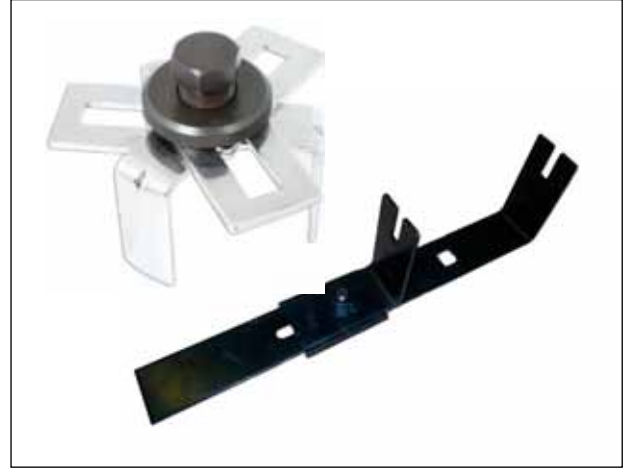

16. Undo the sender unit lock ring using a lock ring tool, these are available from all good tool suppliers.



17. Carefully remove sender unit from tank and cover sender hole whilst working on the sender unit to prevent any dirt or debris falling into the fuel tank.

-  Take extra care when drilling the sender so as not to cause damage to any components beneath the drilling point and clean out any swarf to prevent blockages after refitting.

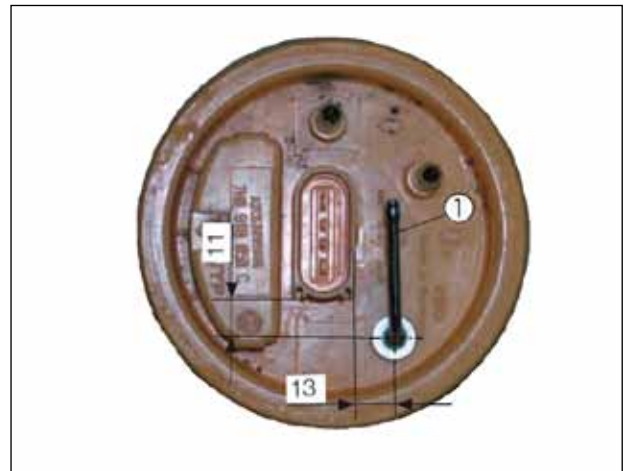

18. Drill an 8.5mm hole in sender unit for standpipe fitting as illustrated in Figure 18.



## INSTALLATION INSTRUCTIONS



19. On certain installations it may be necessary to bend the standpipe slightly, as shown. If required, LEAVE the nylon insert in the standpipe and bend it carefully to the desired angle.

Note: Remember to remove the nylon insert before fitting.



20. Cut the blue fuel line to 150mm at a 45° angle on one end, attach the blue pipe to the sender pick-up using the rubber connection piece and 9mm clips, then cable tie in place to prevent interference with the sender. Ensure that the angled cut is at the bottom of the sender.

 Ensure that the fuel line will not cause any interference when the sender is compressed on fitment to the tank.



21. Refit sender to fuel tank and tighten lock ring. Clip heater fuel line into spare clips on tank with vehicle fuel lines.

## INSTALLATION INSTRUCTIONS



22. Bolt the heaters fuel metering pump to the black splashguard bracket located at the front of the fuel tank.

Ensure that the fuel metering pump is oriented to an angle of between  $15^{\circ}$  and  $35^{\circ}$  with the electrical cables at the top of the pump.

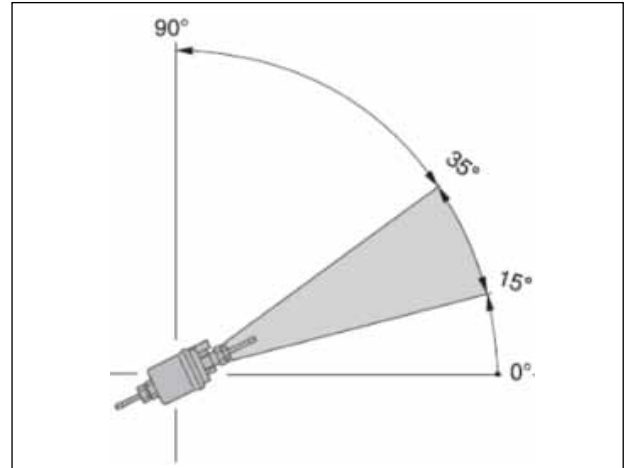

- 22a.



23. Route the battery cable and fuel pump cable from the heater towards the front of the vehicle, over the top of the exhaust heat shield towards the front of the vehicle, keeping them clear of heat sources and sharp edges.

Take the fuel pump loom to the fuel metering pump and connect. Continue to run the power loom, following the brake/fuel lines and use the spare clips above vehicle fuel lines to secure it to.

 DO NOT CLIP UNPROTECTED CABLES TO BRAKE/FUEL LINES.



24. Refit the plastic covers to the underside of the vehicle and ensure that there is no interference with any parts of the heater or exhaust.

# INSTALLATION INSTRUCTIONS



25. Once the 801 controller is positioned (example of 801 modulator mounted shown in Figure 25), connect the switch loom to the 801 loom using the terminals and housing provided, connection should be as follows:

Red cable	Connect to pin 1	BAT +
Yellow cable	Connect to pin 2	ON +
Brown/White cable **	Connect to pin 3	** ECU -
Grey/Red cable	Connect to pin 4	MOD $\Omega$
Grey cable *	Connect to pin 5	* $\Omega$
Blue/White cable	Connect to pin 6	DIAG

\* The grey cable is an optional connection for measuring the temperature at the 801 rather than internally at the heater.

\*\* The brown/white Digital Modulator cable must be connected to the heater brown/white (ECU-) cable.



26. Position the fuse holder in an area located close to the battery and then connect the power loom using a 20 amp and 5 amp fuse.



27. Trim ducting and fit outlets to suit the vehicle as interiors may vary across different installations.



28. Example of a rotary outlet mounted in a finished van.

© Eberspächer (UK) Ltd. 2015

No part of this manual may be copied or reproduced in any form without the express permission of Eberspächer (UK) Ltd.

This publication was correct at the time of going to print however, Eberspächer (UK) Ltd have a policy of continuous improvement and reserve the right to amend any specifications without prior notice.

---

**Eberspächer (UK) Ltd**

Climate House

Yeoman Road, Ringwood

Hampshire BH24 3FA

Tel: 01425 480151

Fax: 01425 480152

[enquiries@eberspaecher.com](mailto:enquiries@eberspaecher.com)

[www.eberspaecher.com](http://www.eberspaecher.com)

