

Eberspächer Climate Control Systems
GmbH & Co. KG
Eberspächerstraße 24
73730 Esslingen
Germany
info@eberspaecher.com
www.eberspaecher.com

EN

**The troubleshooting and repair instructions
are applicable to the following unit versions only**

Heater		Order no.	Heater		Order no.
Hydronic M8 Biodiesel	12 V	25 2470 05 00 00	Hydronic M12	12 V	25 2472 05 00 00
	24 V	25 2471 05 00 00		24 V	25 2473 05 00 00
Hydronic M10	12 V	25 2434 05 00 00			
	24 V	25 2435 05 00 00			

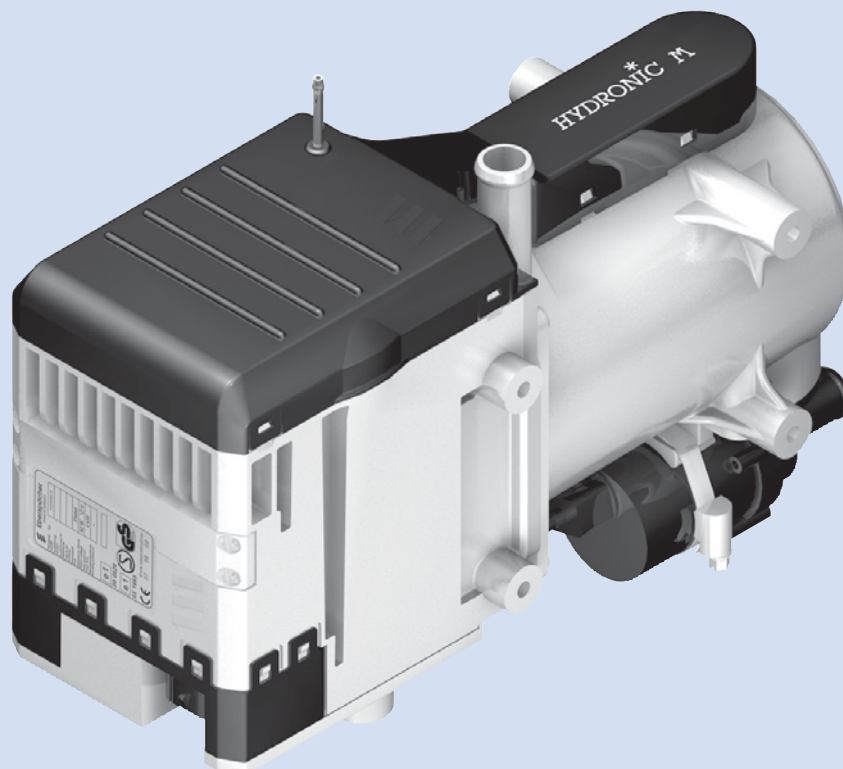

1 Introduction

Contents

This list of contents gives you precise information about the contents of the Troubleshooting and Repair Instructions.

If you are looking for a term, technical term or you would like an abbreviation explained, please use the relevant index at the end of the instructions, from page 54.

Chapter	Title	Contents	Page
1	Introduction	<ul style="list-style-type: none"> • Contents 2 – 3 • Foreword 4 • Safety instructions for installation and repair 4 • Accident prevention 4 • Special text structure, presentation and picture symbols 4 	
2	Function	<ul style="list-style-type: none"> • Cutaway view 5 • Description of functions 6 • Control and safety devices 7 • Forced ADR / ADR99 shutdown 7 • Emergency stop (EMERGENCY OFF) 7 	
3	Product information	<ul style="list-style-type: none"> • Technical data, heater 8 – 10 • Technical data, water pump 11 	
4	Troubleshooting	<ul style="list-style-type: none"> • What to check first in case of faults 12 • Cancel the control box lock 12 • Overview of testing equipment 13 • Fault diagnosis using the diagnostic unit 14, 15 • Fault diagnosis using the EDITH diagnostics tool 16 • Fault diagnosis using the EasyStart R+ radio remote control and EasyStart T timer 17 • Fault code table 18 – 20 	
5	Repair instructions	<ul style="list-style-type: none"> • Repair instructions 21 • Always observe the following safety instructions before working on the heater 21 • Special tool, AMP release tools 21 • Assembly drawing 22 • Component parts / Notes on various components 23 • Preparatory work for all repairs 24 • Repair step 1 <ul style="list-style-type: none"> – Dismantle control box / blower unit and jacket 24 – Remove overheating and temperature sensor 24 – Remove water pump connector 25 – Remove side cover and jacket 25 – Remove electric motor cover 25 – Disconnect 14-pin connector at control box and release cables 26 – Remove flame sensor 27 – Dismantle combustion chamber 27 • Repair step 2 <ul style="list-style-type: none"> – Assemble control box / blower unit and jacket 28 – Install combustion chamber seal 28 – Install grommet 28 – Insert combustion chamber 28 – Install combustion chamber 29 – Lay sensor lead harness and leads for glow plugs 29 – Install flame sensor 30 – Connect flame sensor lead harness and electric motor leads 30 – Connect the glow plug leads 31 – Install electric motor cover 32 – Assemble control box / blower unit and jacket 32 – Lay water pump lead harness 33 – Install overheating and temperature sensor 33 – Install impeller cover 34 	



1 Introduction

Contents

Chapter	Title	Contents	Page
5	Repair instructions	<ul style="list-style-type: none">• Repair step 3 35<ul style="list-style-type: none">– Remove / check glow plug 35– Install glow plug 35– Clean ignition air drillhole..... 35• Repair step 4 36<ul style="list-style-type: none">– Remove spark plug socket lining..... 36– Install spark plug socket lining..... 36• Repair step 5 37<ul style="list-style-type: none">– Check overheating and temperature sensor..... 37• Repair step 6 38<ul style="list-style-type: none">– Check flame sensor 38• Repair step 7<ul style="list-style-type: none">– Remove / attach water pump 39• Measuring the fuel quantity..... 40	
6	Circuit diagrams	<ul style="list-style-type: none">• Heater wiring..... 41• Notes on rewiring the 12-pin cable harness connector 41• Circuit diagram: Hydronic M-II – 12 volt / 24 volt 42• Parts list: Hydronic M-II – 12 volt / 24 volt 43• Circuit diagram: Hydronic M-II – ADR – 12 volt / 24 volt 44• Parts list: Hydronic M-II – ADR/ADR99 – 12 volt / 24 volt 45• Parts list: EasyStart R+ / R / T and EasyStart T – ADR control units 46• Circuit diagram, EasyStart R+ control units 47• Circuit diagram, EasyStart R+ control units 48• Circuit diagram, EasyStart T control units..... 49• Circuit diagram, control units, EasyStart T – ADR 50	
7	Service	<ul style="list-style-type: none">• Certifications 51• Disposal 51• EC Declaration of Conformity 51• List of keywords..... 52• List of abbreviations 53	

1 Introduction

Foreword

These Troubleshooting and Repair Instructions are applicable to the heaters listed on the title page, to the exclusion of all liability claims.

Depending on the version or revised status of the heater, there may be differences between it and these troubleshooting and repair instructions.

The user must check this before carrying out the repair work and, if necessary, take the differences into account.



Caution!

Safety instructions for installation and repair!

Improper installation or repair of Eberspächer heaters can cause a fire or result poisonous exhaust entering the inside of the vehicle. This can cause serious and even fatal risks.

The heater may only be installed according to the specifications in the technical documents or repaired using original spare parts by authorised and trained persons. Installation and repairs by unauthorised and untrained persons, repairs using non-original spare parts and without the technical documents required for installation and repair are dangerous and therefore are not permitted.

A repair may only be carried out in connection with the respective unit-related technical description, installation instructions, operating instructions and maintenance instructions. This document must be carefully read through before / during installation and repair and followed throughout. Particular attention is to be paid to the official regulations, the safety instructions and the general information.

Please note!

The relevant rules of sound engineering practice and any information provided by the vehicle manufacturer are to be observed during the installation and repair.

Eberspächer does not accept any liability for defects and damage, which are due to installation or repair by unauthorised and untrained persons.

Compliance with the official regulations and the safety instructions is prerequisite for liability claims. Failure to comply with the official regulations and safety instructions leads to exclusion of any liability of the heater manufacturer.

Accident prevention

General accident prevention regulations and the corresponding workshop and operating safety instructions are to be observed.

Special text structure, presentation and picture symbols

Special text formats and picture symbols are used in these instructions to emphasise different situations and subjects. Please refer to the following examples for their meanings and appropriate action.

Special text formats and presentations

- A dot (•) indicates a list, which is started by a heading.
 - If an indented dash (–) follows a "dot", this list is a subsection of the black dot.

Picture symbols



Danger!

This information points out a potential serious or fatal danger. Ignoring this information can result in severe injuries.



Caution!

This information points out a dangerous situation for a person and / or the product. Failure to comply with these instructions can result in injuries to people and / or damage to machinery.



2 Function

Cutaway view

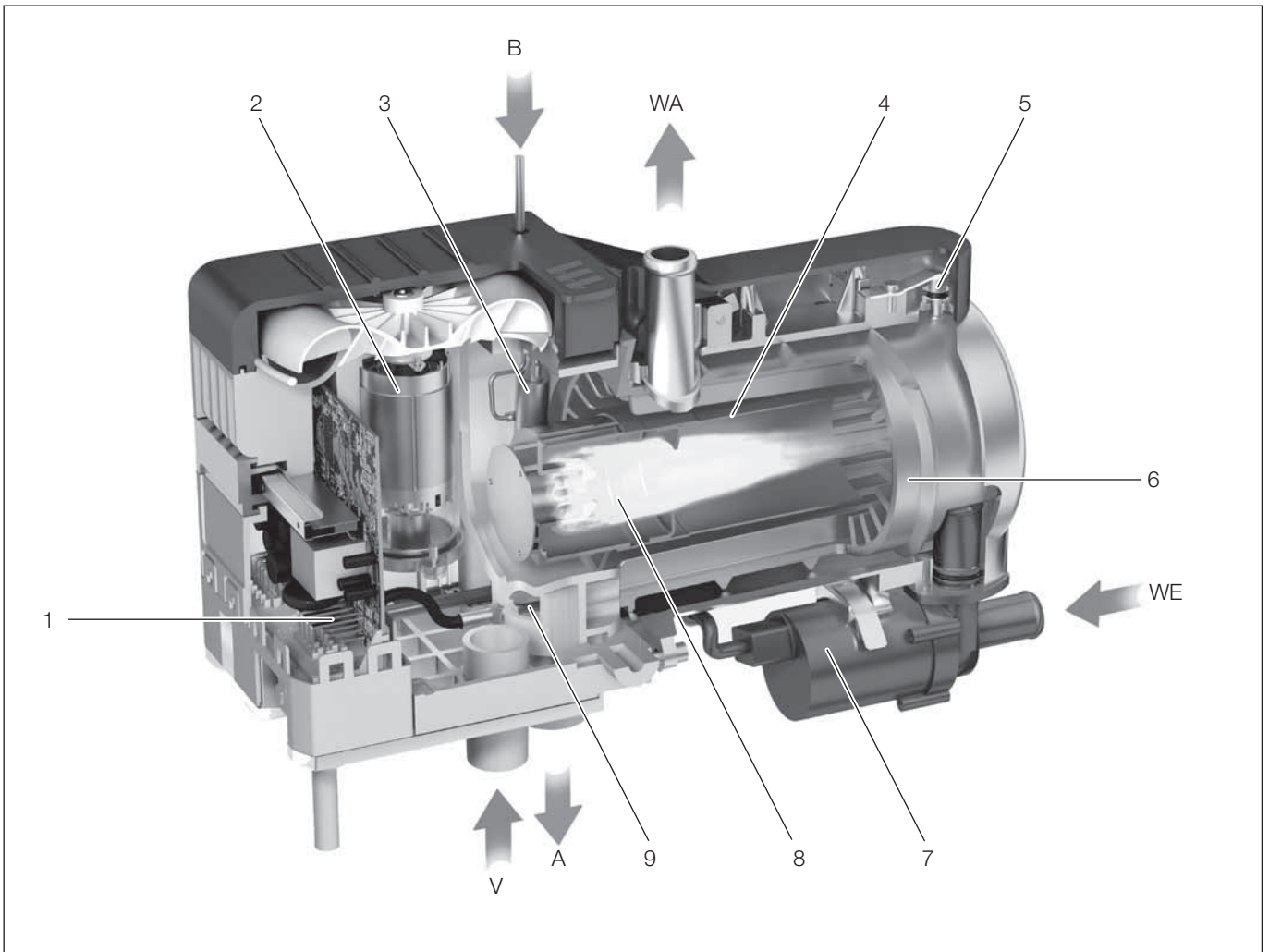

- 1 Control box
- 2 Burner motor
- 3 Glow plug
- 4 Flame pipe
- 5 Overheating sensor
- 6 Heat exchanger
- 7 Water pump
- 8 Combustion chamber
- 9 Flame sensor

- WE = Water inlet
- WA = Water outlet
- A = Exhaust
- B = Fuel
- V = Combustion air

2 Function

Description of functions

Switching on

On being switched on, the switch-on check is displayed in the control unit (EasyStart R+ / EasyStart T). The heater starts with a pre-set program, whereby the water pump and the combustion air blower start up first.

The metering pump starts pumping the fuel with a slight delay. The glow phase of the glow plugs starts at the same time as discharge of the combustion air.

The glow plugs are switched off once a stable flame has formed in the combustion chamber.

Heating mode

The first time it is started up, the heater is run with the "POWER" stage until the water temperature exceeds the "POWER" / "HIGH" changeover threshold.

Hydronic M8 / M10

Then, depending on the heat requirement, the heater runs in the "HIGH – MEDIUM – LOW – OFF" stages only.

If the heating requirement in the "LOW" stage is so small that the cooling water temperature reaches 85 °C, the heater switches from "LOW" to "OFF".

Hydronic M12

Then, depending on the heat requirement, the heater runs in the "HIGH – MEDIUM 1 / MEDIUM 2 / MEDIUM 3 – LOW – OFF" stages only.

If the heating requirement in the "LOW" stage is so small that the cooling water temperature reaches 85 °C, the heater switches from "LOW" to "OFF".

The after-run follows with additional after-glowing of the glow plugs (as when the heater is switched off).

After the cooling water has cooled to approx. 70 °C the Hydronic M8 / M10 heater starts in "MEDIUM" stage, the Hydronic M12 heater in "MEDIUM 1" stage.

If the cooling water temperature reaches approx. 55 °C the temperature sensor switches on the vehicle fan.

Switching off

On being switched off the heater starts the after-run of 180 sec. During the after-run, after 90 seconds the first glow plug is switched on for 45 seconds, then the second glow plug is switched on until the end of the after-run.

Temperature drop

Temperature drop only becomes active while the vehicle is running and if the heater is switched on. The control stages are reached earlier; 58 °C instead of 68 °C and 45 °C instead of 63 °C. The heater's control action is adjusted to the lower heat requirement.

The temperature drop is made possible by connecting the positive cable (D+) to connector S2, terminal C3, of the heater (see circuit diagrams, page 42 and 44).



2 Function

Control and safety devices

The heater is equipped with the following control and safety devices.

- If the heater does not ignite within 74 seconds after the fuel starts to pump, the start is repeated.
If the heater still does not ignite after another 65 seconds of fuel being pumped, the heater is automatically shut down. After an unacceptable number of failed start attempts, the control box is locked.*
 - If the flame goes off by itself during operation, the heater is restarted.
If the heater does not ignite within 74 seconds after the fuel starts to pump again, the heater is automatically shut down. The shutdown on faults can be cancelled by briefly switching off and on again.
 - In the case of overheating (e.g. water shortage, poorly ventilated cooling water circuit), the overheating sensor triggers, the fuel feed is interrupted and the heater is automatically shut down.
Once the cause of the overheating has been eliminated, the heater can be re-started by switching it off and on again (provided that the heater has cooled down sufficiently, cooling water temperature < 70 °C).
After the heater has been shut down due to overheating an unacceptable number of times, the control box is locked.*
- * The lock can be cancelled and the faults read out:
- with the EasyStart T timer
 - with the EasyStart R+ radio remote control.
- In other control units
- with the diagnostics unit
 - using the EDITH diagnostics tool.
- For operation and fault list, please refer to the enclosed operating instructions or these troubleshooting and repair instructions.
- If the water temperature is +50 °C or higher, the heater can also switch to control stage OFF if the water throughput rate is too low. An afterrun of approx. 180 seconds follows.
 - If the lower or upper voltage limit is reached, the heater is automatically shut down.
 - The heater does not start up if the electric cable to the metering pump is interrupted.
 - If one of the two glow plugs is defective, the start sequence takes place with one glow plug only.
 - The speed of the blower motor is continuously monitored. If the blower motor does not start up, if it is blocked or if the speed differs by > 12.5 % of the desired speed, the heater is automatically shut down after 60 sec.
 - The function of the water pump is continuously monitored.

Please note!

Do not repeat the switching off / on routine more than twice.

Forced shutdown during ADR / ADR99 operation

In vehicles for the transport of dangerous goods (e.g. tanker trucks), the heater must be switched off before the truck drives into a danger area (refinery, petrol station, etc.) Failure to comply results in the heater automatically switching off if:

- The vehicle engine is switched off.
- An additional unit is started up (auxiliary drive for unloading pump, etc.)
- A vehicle door is opened (ADR99 regulation, only in France). This is followed by a short after-run of the blower for max. 40 seconds.

Emergency stop – EMERGENCY OFF

If an emergency stop – EMERGENCY OFF – is necessary during operation, complete the following:

- Switch the heater off at the control element or
- remove the fuse or
- disconnect the heater from the battery.

3 Product information

Technical data

Heater type	Hydronic M-II				
Heater	Hydronic M8 Biodiesel				
Version	D 8 W				
Heating medium	Mixture of water and coolant (50 % water, 50 % coolant)				
Control of the heat flow	Power	High	Medium	Low	
Heat flow (watt) Details for operation with diesel fuel. The heat flow can reduce by up to 15 % if operated with FAME.	8000	5000	3500	1500	
Fuel consumption (l/h)	0.90	0.65	0.40	0.18	
Electrical power consumption (watt)	during operation	55	46	39	35
	on starting – after 25 sec.	200			
	during the "OFF" pause mode	32			
Rated voltage	12 volt		24 volt		
Operating range • Lower voltage limit: An undervoltage protection installed in the control box switches off the heater if the lower voltage limit is reached.	10 volt		20 volt		
	15 volt		30 volt		
• Upper voltage limit: An overvoltage protection installed in the control box switches off the heater if the upper voltage limit is reached.					
Allowable operating pressure	up to 2.0 bar overpressure				
Water flow rate of the water pump towards 0.14 bar	1400 l/h				
Minimum water flow rate of the heater	500 l/h				
Fuel	Diesel – commercially available (DIN EN 590) FAME – for diesel engines according to DIN EN 14 214				
Allowable ambient temperature			during operation	without operation	
	Heater / Control box	Diesel	-40 °C to +80 °C	-40 °C to +85 °C	
		FAME	-8 °C to +80 °C	-40 °C to +85 °C	
	Metering pump	Diesel	-40 °C to +50 °C	-40 °C to +85 °C	
FAME		-8 °C to +50 °C	-40 °C to +85 °C		
Interference suppression class	5 according to DIN EN 55025				
Weight – with control box and water pump, without metering pump	ca. 6.2 kg				

Please note!

Provided no limit values are given, the technical data provided is with the usual heater tolerances of $\pm 10\%$ at rated voltage, 20 °C ambient temperature and reference altitude Esslingen.



Caution!

Failure to comply with the technical data can result in malfunctions.



3 Product information

Technical data

Heater type	Hydronic M-II				
Heater	Hydronic M10				
Version	D 10 W				
Heating medium	Mixture of water and coolant (50 % water, 50 % coolant)				
Control of the heat flow	Power	High	Medium	Low	
Heat flow (watt)	9500	8000	3500	1500	
Fuel consumption (l/h)	1.2	0.9	0.4	0.18	
Electrical power consumption (watt)	during operation	86	60	39	35
	on starting – after 25 sec.	120			
	during the "OFF" pause mode	32			
Rated voltage	12 volt		24 volt		
Operating range	10 volt		20 volt		
	15 volt		30 volt		
Allowable operating pressure	up to 2.0 bar overpressure				
Water flow rate of the water pump towards 0.14 bar	1400 l/h				
Minimum water flow rate of the heater	500 l/h				
Fuel	Diesel – commercially available (DIN EN 590)				
Allowable ambient temperature	during operation		without operation		
	Heater / Control box		-40 °C to +85 °C		
	Metering pump		-40 °C to +85 °C		
Interference suppression class	5 according to DIN EN 55025				
Weight – with control box and water pump, without metering pump	ca. 6.2 kg				



Caution!

Failure to comply with the technical data can result in malfunctions.

Please note!

Provided no limit values are given, the technical data provided is with the usual heater tolerances of $\pm 10\%$ at rated voltage, 20 °C ambient temperature and reference altitude Esslingen.

3 Product information

Technical data

Heater type	Hydronic M-II						
Heater	Hydronic M12						
Version	D 12 W						
Heating medium	Mixture of water and coolant (50 % water, 50 % coolant)						
Control of the heat flow	Power	High	Medium 1	Medium 2	Medium 3	Low	
Heat flow (watt)	12000	9500	5000	3500	1500	1200	
Fuel consumption (l/h)	1.5	1.2	0.65	0.40	0.18	0.15	
Electrical power consumption (watt)	during operation	132	86	46	39	35	34
	on starting – after 25 sec.	120					
	during the "OFF" pause mode	32					
Rated voltage	12 volt			24 volt			
Operating range	<ul style="list-style-type: none"> Lower voltage limit: An undervoltage protection installed in the control box switches off the heater if the lower voltage limit is reached. 			20 volt			
				<ul style="list-style-type: none"> Upper voltage limit: An overvoltage protection installed in the control box switches off the heater if the upper voltage limit is reached. 			30 volt
Allowable operating pressure	up to 2.0 bar overpressure						
Water flow rate of the water pump towards 0.14 bar	1400 l/h						
Minimum water flow rate of the heater	500 l/h						
Fuel	Diesel – commercially available (DIN EN 590)						
Allowable ambient temperature	during operation			without operation			
	Heater / Control box			-40 °C to +85 °C			
	Metering pump			-40 °C to +85 °C			
Interference suppression class	5 according to DIN EN 55025						
Weight – with control box and water pump, without metering pump	approx. 6.2 kg						

Please note!

Provided no limit values are given, the technical data provided is with the usual heater tolerances of $\pm 10\%$ at rated voltage, 20 °C ambient temperature and reference altitude Esslingen.



Caution!

Failure to comply with the technical data can result in malfunctions.



3 Product information

Technical data

Water pump

Rated voltage	12 volt	24 volt
Operating voltage	8.5 volt to 16 volt	18 volt to 33 volt
Electrical power consumption	32 watt	
Water flow rate around 0.3 bar	700 l/h	
Operating temperature	-40 °C to +100 °C	
Storage temperature	-40 °C to +120 °C	

Technical data $\pm 10\%$



Caution!

Failure to comply with the technical data can result in malfunctions.

Delivery curve of the water pump

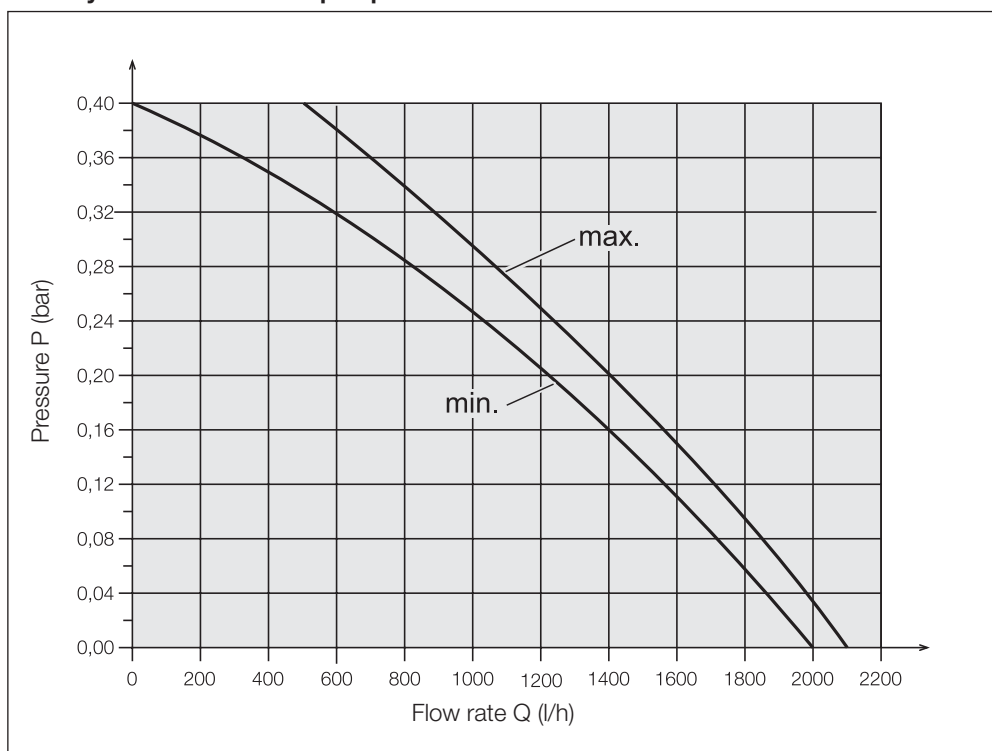

4 Troubleshooting

What to check first in case of faults

-
- **Check whether:**
 - Fuel in the tank?
 - Fuel pipes leaking? (visual check)
 - Summer diesel still in the fuel pipe?
 - Heating lever (water valve) fully set to "HOT"?
 - Combustion air system or exhaust system damaged or blocked?
- **Electrical components:**
 - Cables, connections damaged?
 - Contacts corroded?
 - Fuses defective?
 - Incorrect wiring? (short circuits, interrupted / broken)
- **Check battery voltage**
 - Battery voltage < 10 volt, the undervoltage protection of the 12 volt heater has triggered.
 - Battery voltage < 20 volt, the undervoltage protection of the 24 volt heater has triggered.
- **Check voltage supply U_{Batt} (Terminal 30)**

Disconnect the 12-pin connector (B2) and measure the voltage applied at the control box / blower unit between chamber A3 (cable 2.5² rt) and chamber A2 (cable 2.5² br). If it differs from the battery voltage, check the fuses, the supply cables, the negative connection and the positive support point on the battery for voltage drop (corrosion / interruption).
- **Check switch-on signal (S+)**

If using the EasyStart R+, R and T control units.
Disconnect the 12-pin connector (B2) at the control box / blower unit and then use the control unit to switch on the heater.
Measure the applied voltage in the connector (B2) between chamber B4 (cable 0.75² bl/ws) and chamber A2 (cable 2.5² br). If no voltage is applied, then check the supply cable (cable 1² ge), the 5 A fuse (Item 2.7.1 in the circuit diagram) and the control unit.

In all other control units

Disconnect the 12-pin connector (B2) at the control box / blower unit and then press the button  on the control unit. Measure the applied voltage in the connector (B2) between chamber C4 (cable 1² ge) and chamber A2 (cable 2.5² br). If no voltage is applied, then check the supply cable (cable 1² ge), the 5 A fuse (Item 2.7.1 in the circuit diagram) and the control unit.

Cancel the control box lock

Cancellation of the control box lock depends on the appropriate test equipment and is described on pages 14 to 17.



4 Troubleshooting

Overview of the individual test equipment and control units

The electronic control box can store up to 5 faults, which can be read out and displayed. The following test equipment can be used to query the fault memory in the control box and if necessary to delete the locking of the control box:

Testing equipment	Order No.:
• Diagnostic unit	22 1529 89 00 00
– also required: Adapter cable	22 1000 33 44 00
• EDiTH-Basic diagnostics tool	22 1541 89 00 00
– also required: Adapter cable	22 1000 33 44 00

If the diagnostics cable is connected, the following control units can also be used to query the fault memory in the control box and if necessary to delete the locking of the control box:

Control units	Order No.:
• EasyStart T	22 1000 32 88 00
• EasyStart R+	22 1000 32 80 00

Please note!

If the fault memory cannot be read out, check the diagnostics cable is properly laid and is not damaged.

External diagnostics system

With an external, vehicle-specific diagnostics system
-> Consult the vehicle manufacturer.

4 Troubleshooting

Diagnostic unit

(Order No.: 22 1529 89 00 00)

An adapter cable is also required to connect the diagnostic unit (Order No.: 22 1000 33 44 00).

The current fault is displayed as "AF" and a 2-digit number and is always written in the memory location F1. Preceding faults are moved to the memory locations F2 – F5, if necessary the content of memory location F5 is overwritten.

Please note!

- It is very important to always install in the given order.
- Not only the defective component, but also a defective current circuit results in a fault being displayed.
- Fault code, fault description, cause / remedial action are described on pages 18 to 20.

Connect diagnostic unit

Disconnect the cable loom. Connect the adapter cable to the heater. Connect the cable loom to the adapter cable, housing connector.

Connect the adapter cable with the cable loom connector of the diagnostic unit (new version)

or

Connect the adapter cable with the cable loom connector of the diagnostic unit (old version). Then connect the 8-pin connector to the diagnostic unit (old version).

Start the diagnosis query.



Query the fault memory

- Use the **D** button to switch on the heater.

The display is as follows:

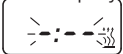

- After 8 sec. the following is displayed:

The display is as follows:



Heater has no malfunction

or

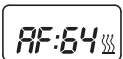

e.g. current fault / fault code 64

or



Fault diagnosis is not possible

Possible causes:

- Adapter cable is not properly connected.
- Control box is defective or has no diagnosis capability (no universal control box).



- L** – Delete fault memory
- L** – Delete fault memory
- D** – Switch heater On / Off, request diagnosis
- <** – Reverse, F5 – F1
- >** – Forward, F1 – F5, current fault (AF)

Display of the fault memory F1 – F5 or F5 – F1

- Press the button **<** or **>** once or several times to display the fault memory.

The display is as follows:

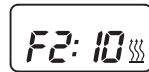

e.g. fault memory 2 / fault code 10

Please note!

Only the fault memory locations with a fault assigned to them are displayed.

Delete fault memory

- Press both **L** buttons simultaneously until the following is displayed:

The display is as follows:

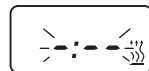

- If all the fault memory locations have been deleted the most recent fault is displayed. The current fault is not reset to 00 until the heater is restarted – provided no new fault exists.

The display is as follows:



Heater has no malfunction

4 Troubleshooting

Cancel the control box lock

- Delete the fault memory as described and use the **D** button to switch off the heater.
- The control box lock is cancelled and the diagnosis is ended.

The display is as follows:

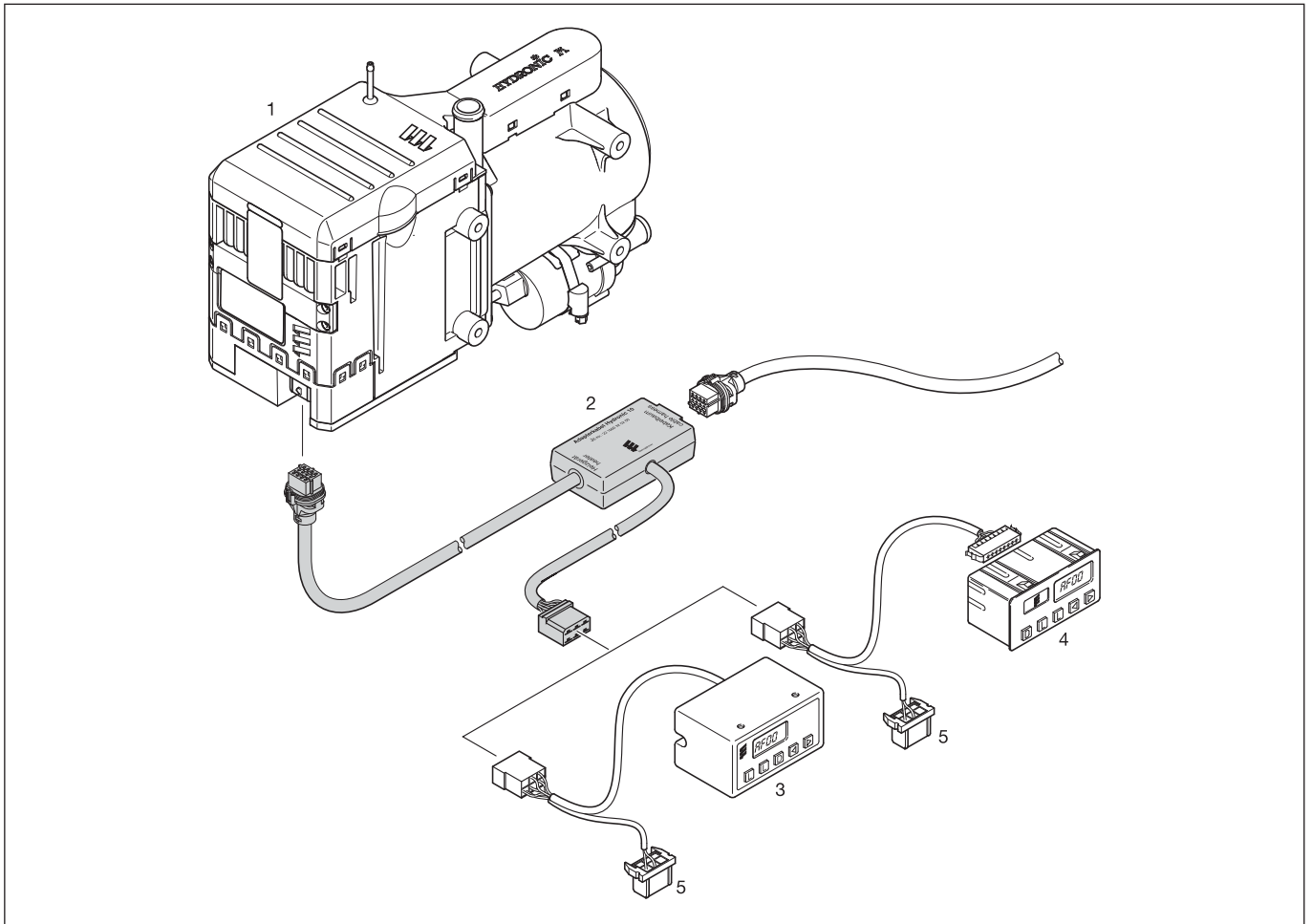

- 1 Heater
- 2 Adapter cable
- 3 Diagnostic unit
- 4 Diagnostic unit (old version, no longer available)
- 5 Connector housing, is not connected.

4 Troubleshooting

EDiTH-Basic diagnostic tool

(Order No.: 22 1541 89 00 00)

An adapter cable is also required

(Order No.: 22 1000 33 44 00).

Please note!

- It is very important to always install in the given order.
- Not only the defective component, but also a defective current circuit results in a fault being displayed.
- The fault code, fault description, cause / remedial action are described on pages 18 to 20.
- The EDiTH-Basic diagnostic tool scope of delivery does not include the software, this must be downloaded from the Service Portal.

Connect EDiTH-Basic

Disconnect the cable loom.

Connect the adapter cable connector to the heater.

Connect the cable loom to the adapter cable housing connector.

Connect the adapter cable with the cable loom connector of the EDiTH-Basic.

Connect the SUB-D connection cable with the EDiTH-Basic and at the PC.

Start the diagnosis query.

Install software on the PC

- Double-click to start the "setup.exe" file and follow the instructions of the SETUP program.

Query/Delete fault memory F1 – F5 or cancel the control box lock

- Start the software at the PC:
 - on the Desktop → double-click the "EDiTH" icon
 - select heater type
 - press the "GO" button.
- Delete fault memory or cancel the control box lock:
 - press the "Delete fault memory" button
 - the stored faults F1 – F5 are deleted and the control box is unlocked.

Quit diagnosis

- Press the "STOP" button → the fault memory query is ended.

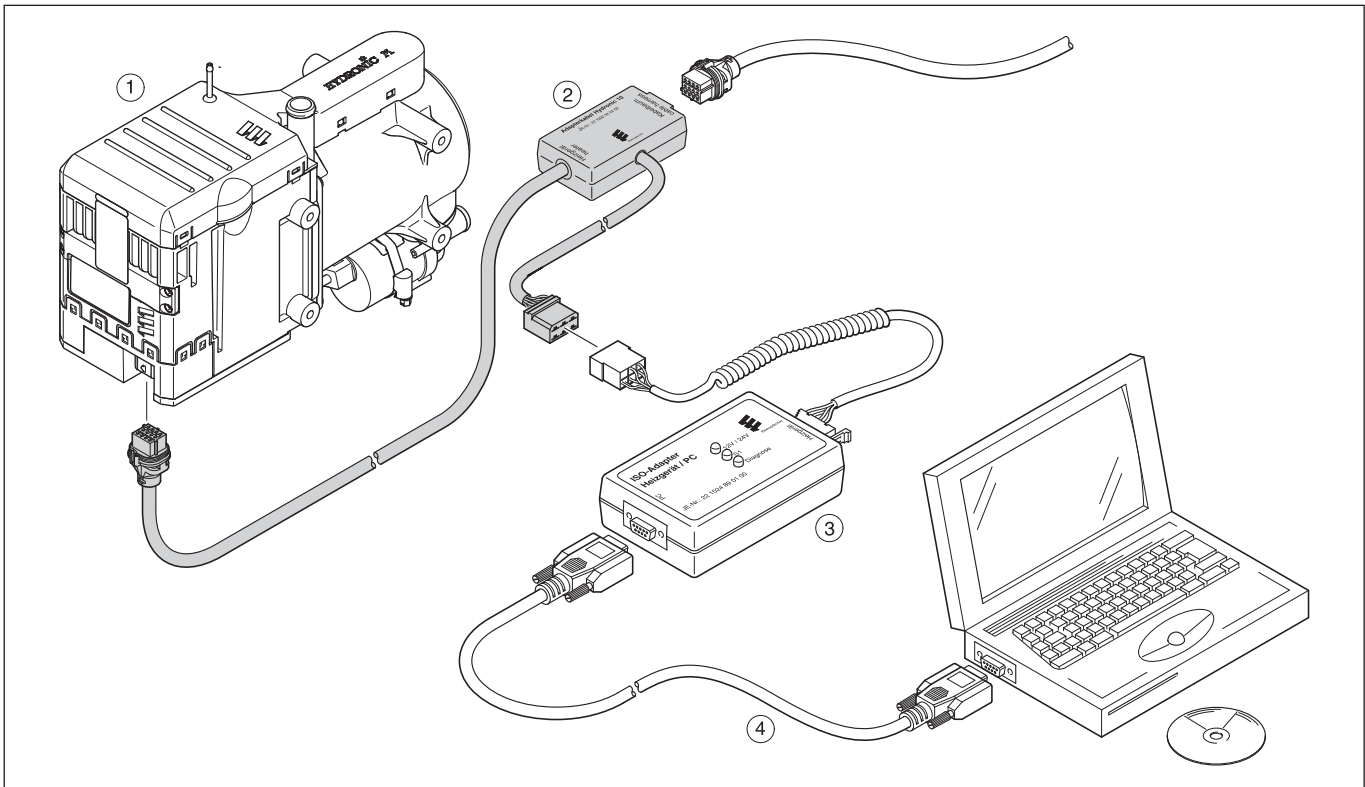

- 1 Heater
- 2 Adapter cable
- 3 EDiTH-Basic
- 4 SUB-D connection cable

4 Troubleshooting



EasyStart R+ radio remote control

(Order No.: 22 1000 32 80 00)

EasyStart T timer

(Order No.: 22 1000 32 88 00)

If faults occur in the heater while it is running, they are displayed with "Err" after the mobile unit or timer has been activated.

The current fault is displayed. The stored faults "F1" to "F5" can be queried.

Please note!

- The bl/ws diagnostics cable must be connected in order to perform the diagnosis. To this end, please refer to and follow the circuit diagram for the radio remote control or the timer and for the heater.
- If the diagnostics cable is not connected, the "Diagnosis" menu is blocked.
- Not only the defective component, but also a defective current circuit results in a fault being displayed.
- The fault code, fault description, cause / remedial action are described on pages 18 to 20.

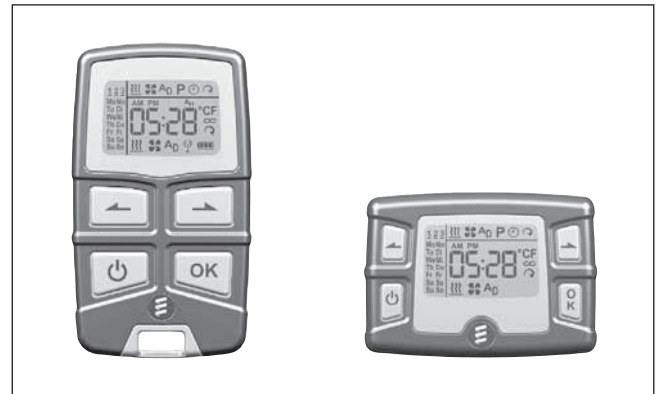

- Back control button
- Next control button
- ON / OFF activation button for mobile unit / timer
- OK button (symbol selection / input confirmation)

Query / delete fault memory

Activate mobile unit / timer
(see EasyStart R+ / EasyStart T operating instructions)

Press to confirm symbol.

Heater is switched on.

Press to confirm operating time.

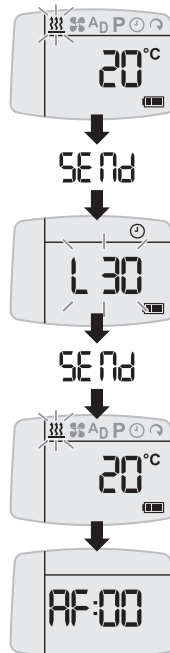

Briefly press and simultaneously.

The following actions are possible:

- Retrieve fault memory.
Use or to retrieve the fault memory F1 – F5.
- Retrieve fault memory again.
Briefly press and simultaneously.
- Delete fault memory (display dEL)
Press .

Press again.

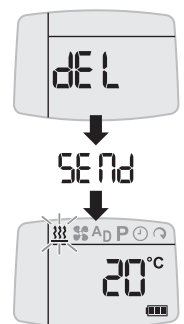

The diagnosis is completed.

Switch off the heater.

4 Troubleshooting

Fault code Display	Fault description	Comments • Remedial action
000	No faults	— —
005	Warning Short circuit in "Burglar Alarm" output	<ul style="list-style-type: none"> • Check connection and / or lead for continuity, short circuit and damage.
009	ADR / ADR99 shutdown	<ul style="list-style-type: none"> • Switch the heater off and then on again – The shutdown must be cancelled by D+ or HA / NA.
010	Overvoltage cutoff	<p>Overvoltage applied to control box for at least 6 seconds without interruption → heater not working.</p> <ul style="list-style-type: none"> • Disconnect heater / cable harness plug-in connector, start the vehicle engine, measure the voltage. Connector B2, PIN A2 and A3: <ul style="list-style-type: none"> – If the voltage is >15 volt or >30 volt, check the generator regulator and / or the battery.
011	Undervoltage cutoff	<p>Undervoltage applied to control box for at least 20 seconds without interruption → heater not working.</p> <ul style="list-style-type: none"> • Disconnect heater / cable harness plug-in connector, start the vehicle engine, measure the voltage. Connector B2, PIN A2 and A3: <ul style="list-style-type: none"> – If the voltage is <10 volt or <20 volt, then check the fuses, the supply cables, the negative connections and the positive support point at the battery for voltage drop (corrosion).
012	Overheating	<p>Overheating sensor signals temperature greater than 120 °C.</p> <ul style="list-style-type: none"> • Vent heater (water shortage), open heater slide valve, check water flow rate. • Measure the resistive value of the overheating sensor, connector B1, PIN 2 and 4, for measured values see page 28. <ul style="list-style-type: none"> – If overheating sensor ok, check connection leads for continuity, short circuit and damage.
014	Difference between the overheating and temperature sensor is too large	<p>Difference between measured value in overheating sensor and temperature sensor greater than 70 K.</p> <ul style="list-style-type: none"> • Vent heater (water deficiency), open heater slide valve and check water flow rate. • Measure the resistive value of the temperature sensor, connector B1, PIN 2 and 4 or connector B1 PIN 1 and 2; for measured values see page 28. <ul style="list-style-type: none"> – If temperature sensor ok, check connection leads for continuity, short circuit and damage.
015	Operating lock-out: Too many overheating events detected.	<ul style="list-style-type: none"> • Delete error to cancel the operating lock-out. • Check water circuit and flow rate.
017	Overheating, Hardware threshold exceeded Control box is locked	<p>Max. temperature exceeded at the overheating sensor (180 °C).</p> <ul style="list-style-type: none"> • Vent heater (water shortage), open heater slide valve, check water flow rate. • Check overheating sensor → fault code 012. • Check control box.
019	Glow plug 1, Ignition energy too low	<p>Glow plug 1 energy input is too low (< 2000 Ws)</p> <ul style="list-style-type: none"> • Check glow plug for continuity, short circuit and damage → Fault code 020. • Check control box.
020	Glow plug 1, interruption	<ul style="list-style-type: none"> • Measure cold resistance of the glow plug at approx. 20 °C ambient temperature – connector B1, PIN 7 and 10.
021	Glow plug 1, overload / short circuit downstream of earth	<p>If the values are as follows the glow plug is ok, if the values differ – replace the glow plug.</p>
022	Glow plug 1, short circuit downstream of +Ub	<p>Measured value:</p> <ul style="list-style-type: none"> • 12 volt – glow plug = 0.42 – 0.6 ohm • 24 volt – glow plug = 1.2 – 1.9 ohm – If the glow plug is ok, check the lead harness of the glow plug for continuity, short circuit and damage.



4 Troubleshooting

Fault code Display	Fault description	Comments • Remedial action
023 024	Glow plug 2, interruption Glow plug 2, overload / short circuit downstream of earth	<ul style="list-style-type: none"> • Measure cold resistance of the glow plug at approx. 20 °C ambient temperature – connector B1, PIN 11 and 14. • If the values are as follows the glow plug is ok, if the values differ – replace the glow plug. • Measured value: <ul style="list-style-type: none"> • 12 volt – glow plug = 0.42 – 0.6 ohm • 24 volt – glow plug = 1.2 – 1.9 ohm – If the glow plug is ok, check the lead harness of the glow plug for continuity, short circuit and damage.
025	JE-K line fault Heater remains ready for operation	<ul style="list-style-type: none"> • Check diagnostics cable for continuity, short circuit and damage – connector B2, PIN B4. – if ok, check control box.
026	Glow plug 2, short circuit downstream of +Ub	see fault code 023 / 024
029	Glow plug 2, Ignition energy too low	<p>Glow plug 2 energy input is too low (< 2000 Ws)</p> <ul style="list-style-type: none"> • Check glow plug for continuity, short circuit and damage. –> Fault code 023. • Check control box.
031 032 033 034	Burner motor, interruption Burner motor, overload Burner motor, speed error / blocked Burner motor short circuit downstream of +Ub or earth	<ul style="list-style-type: none"> • Check the burner motor's connection leads for continuity, short circuit and damage – connector B1, PIN 3, 6 and 9. • Check burner motor for easy movement by manually rotating the impeller – if not smooth running, remove the blockage. – if ok, replace control box / blower unit.
037	Water pump not working	<ul style="list-style-type: none"> • Check water pump. • Apply voltage to the water pump – connector B1, PIN 12 and 13 (power input = max. 4 A or 2 A) – If WP does not rotate, replace WP. – If WP is ok -> replace control box / blower unit.
041 042 043	Water pump, interruption Water pump Overload short circuit Water pump Overload downstream of +Ub	<ul style="list-style-type: none"> • Check the water pump's connection and lead harness for continuity, short circuit and damage – connector B1, PIN 12 and 13. – If ok, check water pump -> fault code 037. <p>Water pump in dry running</p> <ul style="list-style-type: none"> • Vent heater (water shortage), open heater slide valve, check water flow rate
047 048 049	Metering pump Overload short circuit Metering pump interruption Metering pump Overload downstream of +Ub	<ul style="list-style-type: none"> • Check the metering pump's connection and lead harness for continuity, short circuit and damage – connector B2, PIN A1. – If ok, check the metering pump – setpoint value approx. 20 ohm.
050	Operating lock-out: Too many start attempts detected.	<ul style="list-style-type: none"> • Delete error to cancel the operating lock-out. • Check fuel supply. • Remove combustion chamber and check for carbonization / soot formation, replace if necessary.
052	Exceeding of safety time	<p>No flame detected within the start phase. Flame sensor value < 80 °C, therefore automatic shutdown because safety time exceeded.</p> <ul style="list-style-type: none"> • Check fuel supply, exhaust and combustion air system. • Check glow plug -> see fault code 019 to 024 / 026 / 029. • Check flame sensor -> fault code 064 / 065.

4 Troubleshooting

Fault code Display	Fault description	Comments • Remedial action
053	Flame cutout in "POWER" control stage	Heater ignited (flame detected) and signals flame cutout during a power stage.
054	Flame cutout in "HIGH" control stage	<ul style="list-style-type: none"> • Check fuel quantity, blower speed, fuel supply, exhaust and combustion air system.
055	Flame cutout in "Medium" control stage (D 8 W / D 10 W) "Medium1" control stage (D 12 W)	<ul style="list-style-type: none"> • Check flame sensor → fault code 064 / 065.
056	Flame cutout in "Medium 2" control stage (D 12 W)	
057	Flame cutout in "Medium 3" control stage (D 12 W)	
058	Flame cutout in "LOW" control stage	
059	Too rapid rise in water temperature	<ul style="list-style-type: none"> • Vent heater (water shortage), open heater slide valve, check water flow rate. • Check temperature sensor → fault code 060 / 061
060	Temperature sensor interruption	Temperature sensor signals temperature value outside the measuring range.
061	Temperature sensor short circuit	<ul style="list-style-type: none"> • Measure the resistive value of the temperature sensor, Connector B1, PIN 1 and 2; for measured values see page 28. – If temperature sensor ok, check connection leads for continuity, short circuit and damage.
064	Flame sensor interruption	Flame sensor signals temperature value outside the measuring range.
065	Flame sensor short circuit	<ul style="list-style-type: none"> • Measure the resistive value of the flame sensor – connector B1, PIN 5 and 8; for measured values see page 29. – If flame sensor ok, check connection leads for continuity, short circuit and damage.
071	Overheating sensor interruption	Overheating sensor signals temperature value outside the measuring range.
072	Overheating sensor short circuit	<ul style="list-style-type: none"> • Check overheating sensor → fault code 012.
074	Overheating detection hardware is defective, operating lock-out	<ul style="list-style-type: none"> • Control box is defective. Replace control box / blower unit.
090	External reset	<ul style="list-style-type: none"> • Control box reset by external interference voltage. Check voltage supply, e.g. battery, leads, generator, fuses.
091	Internal reset	<ul style="list-style-type: none"> • Internal control box fault, replace control box / blower unit.
092	ROM error	
093	RAM error, at least one RAM cell is not working	
094	EEPROM error, checksum error within the area of the operating data, diagnostic parameters or calibration values	
095	Invalid data record, checksum error	
096	Internal temperature sensor is defective / ECU too hot	
097	Internal device error	
098	Main relay is faulty	
099	Too many resets, operating lock-out	



5 Repair instructions

Repair instructions

The permitted repair work on the heater is described in the "Repair Instructions" chapter. The heater must be removed from the vehicle for the repair work to be carried out.

The heater is assembled in the reverse order, note and follow any additional instructions.

Please note!

After completing all the work and installing the heater in the vehicle, perform a functional check on the heater.

Always observe the following safety instructions before working on the heater



Danger!

Risk of injury, burns and poisoning!

- Always switch off the heater beforehand and leave it to cool.
- Disconnect the battery.
- The heater must not be operated in closed rooms such as garages or workshops.

Exception:

Exhaust suction available directly at the entry to the exhaust pipe.



Caution!

- The seals of dismantled components must be renewed.
- During repair work, check all components for damage and if necessary replace.
- Check connector contacts, plug-in connections and cables for corrosion and damage and if necessary repair.
- Only ever use Eberspächer spare parts if replacements are necessary.
- After working on the coolant circuit the level of the coolant must be checked and if necessary topped up according to the vehicle manufacturer's instructions.
The coolant circuit must then be vented.
- Operation or the after running of the heater may only be stopped in an emergency (see "EMERGENCY OFF" page 7) by interrupting the battery current (risk of heater overheating).

Special tool

AMP release tool

The AMP release tool is used to release plug-in contacts in a connector housing.

This release tool can be ordered directly from AMP.

- For Micro Timer AMP Order No. 0-0539960-1



- For Junior Power Timer AMP Order No. 1-1579007-6

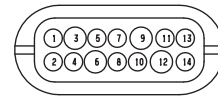
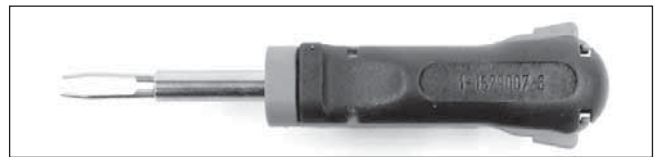

- For Standard Timer, Junior Timer AMP Order No. 1-1579007-4

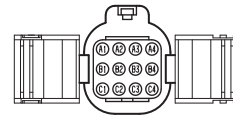

5 Repair instructions

Assembly drawing

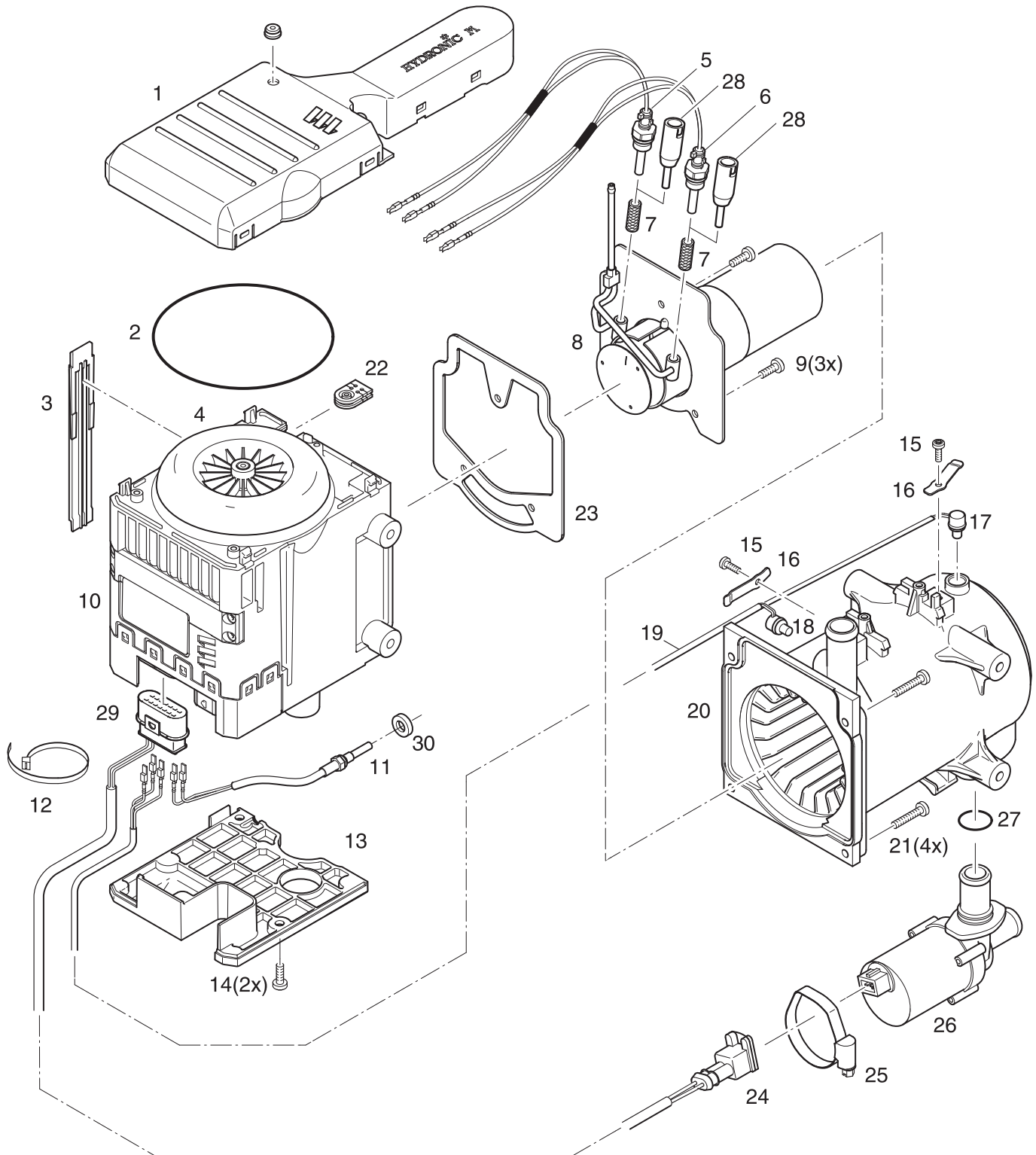



5 Repair instructions

Parts list

1	Impeller cover
2	O-ring 117.07 x 3.53
3	Cover, side
4	Impeller
5	Glow plug 1
6	Glow plug 2
7	Spark plug socket lining
8	Combustion chamber
9	M5 x 16 TAPTITE / DIN 7500 TORX screw
10	Control box / blower unit
11	Flame sensor
12	Cable tie
13	Electric motor cover
14	M5 x 16 TAPTITE / DIN 7500 TORX screw
15	M4 x 12 TAPTITE / DIN 7985 TORX screw
16	Compression spring
17	Overheating sensor
18	Temperature sensor
19	Overheating / temperature sensor cable loom
20	Jacket with heat exchanger
21	M5 x 25 TAPTITE / DIN 7500 TORX screw
22	Grommet
23	Combustion chamber seal
24	Water pump cable loom connector
25	Hose clip
26	Water pump
27	O-ring 19.8 x 2.3
28	Assembly tool for spark plug socket lining
29	14-pin connector
30	Special washer 6.4 x 11 x 3.2 (required for control box / blower unit without strengthening flange)

Please note!

Notes on various components

- **Control box / blower unit, Item 10**

Control box / blower unit and electric motor cannot be dismantled. If these components are defective the complete control box / blower unit must be replaced.

- **Jacket with heat exchanger, Item 20**

The jacket and heat exchanger cannot be dismantled. If these components are defective the complete jacket with heat exchanger component must be replaced.

- **O-ring, Item 2**

The O-ring is included in the scope of supply of the ET part "control box / blower unit". The O-ring is also available as a component part.

- **Combustion chamber seal, Item 23**

The combustion chamber seal is included in the scope of supply of the following ET parts:

- Jacket with heat exchanger (20)
- Combustion chamber (8)
- Glow plug (5) and (6)

The combustion chamber seal is also available as a component part.

5 Repair instructions

Preparatory work for all repairs

Figure 1 and 2

- Clamp the removed heater in a retaining device (vice).
- Using 2 screwdrivers, always undo 2 snap connections of the impeller cover at a time, starting at the control box / blower unit. Keep to the order shown in the figure (1. – 8.)
- Remove cover.
- Remove O-ring (2).

Please note!

The O-ring (2) must always be renewed.

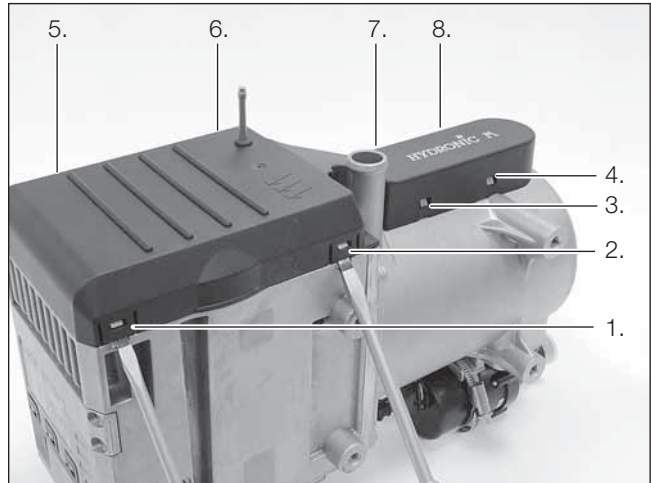
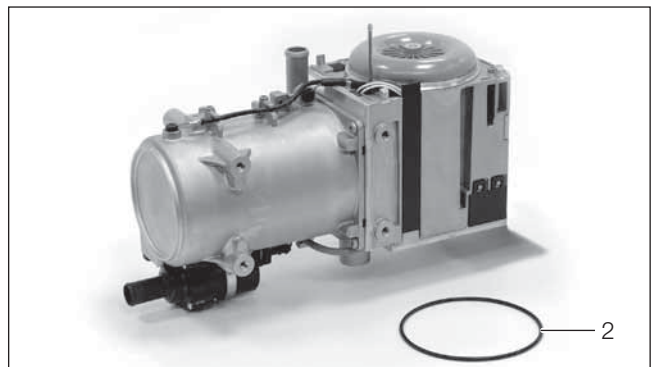

Figure 1



2 O-ring

Figure 2

Repair step 1 Dismantle control box / blower unit and jacket

Remove overheating sensor and temperature sensor

Figure 3 – 5

- Remove the (15) M4 x 12 screws of the compressive springs (16) and use pliers to pull off the overheating (17) and temperature sensor (18).

Please note!

Do not pull out the overheating (17) and temperature sensor (18) from the holder by pulling on the connection cable, always use pliers to remove them.

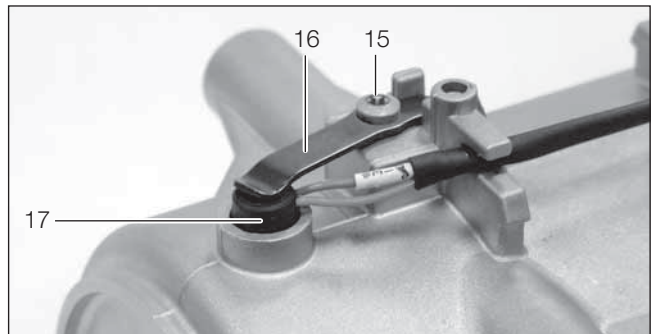

15 M4 x 12 screw
16 Compression spring
17 Overheating sensor

Figure 4

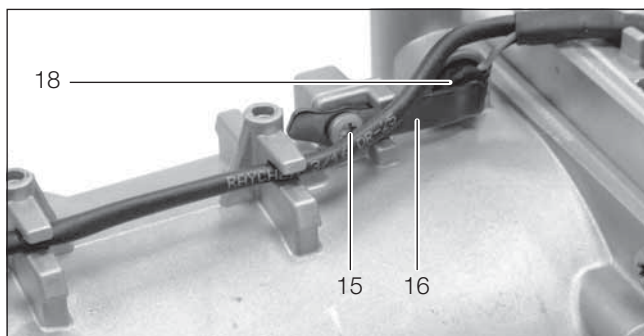

15 M4 x 12 screw
16 Compression spring
18 Temperature sensor

Figure 3

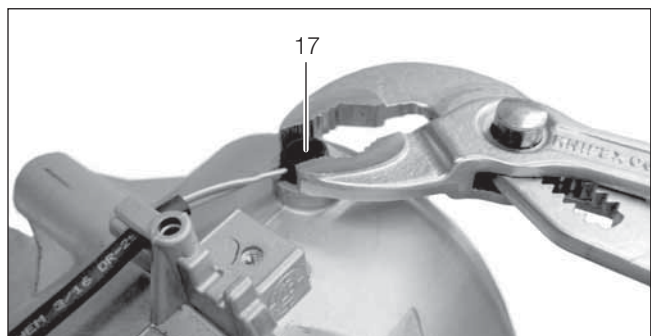

17 Overheating sensor

Figure 5



5 Repair instructions

Repair step 1 Dismantle control box / blower unit and jacket

Remove water pump connector

Figure 6

- Disconnect the connector (24) at the water pump (26) and pull the cable loom out of the holder.

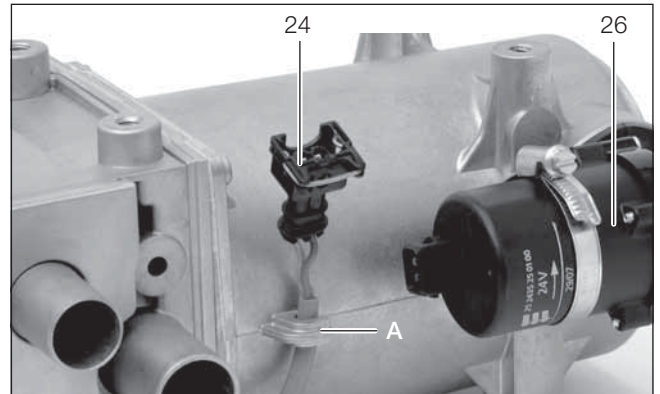

A Holder for cable loom
24 Water pump connector
26 Water pump

Figure 6

Remove side cover and dismantle jacket

Figure 7

- Pull out side cover (3) from above.
- Undo the 4 screws (21) M5 x 25 in the jacket (20) and remove the jacket from the control box / blower unit.

Please note!

The control box / blower unit may not be placed on the exposed impeller.

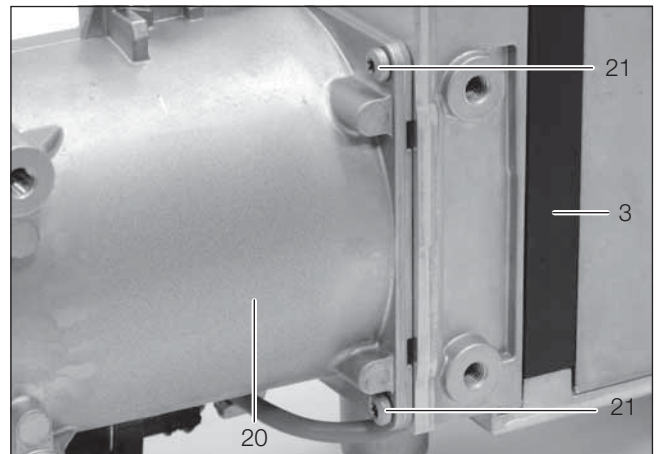

3 Cover, side
20 Jacket
21 M5 x 25 screw (4 screws)

Figure 7

Remove electric motor cover

Figure 8

- Undo the 2 screws (14) M5 x 16 of the electric motor cover (13) and remove the cover.

Please note!

The control box / blower unit may not be placed on the exposed impeller.

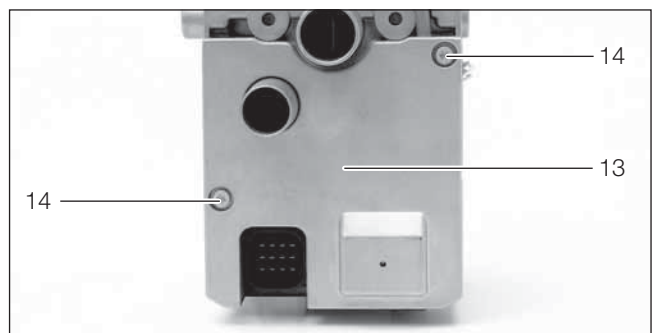

13 Electric motor cover
14 M5 x 16 screw

Figure 8

5 Repair instructions

Repair step 1 Dismantle control box / blower unit and jacket

Disconnect 14-pin connector at control box and release cables

Figure 9 – 11 / Sketch 1

- Use side cutters to open the cable tie (12).
- Disconnect the 14-pin connector (29).
- Use the AMP release tool to release plug-in contacts in the 14-pin connector (29) for the electric motor, flame sensor (11), glow plug 1 (5) and glow plug 2 (6).
- Expose the glow plug leads of both glow plugs from above (cable duct).

Please note!

When replacing the control box / blower unit, the sensor (19) and water pump lead harnesses can be left in the 14-pin connector (29).

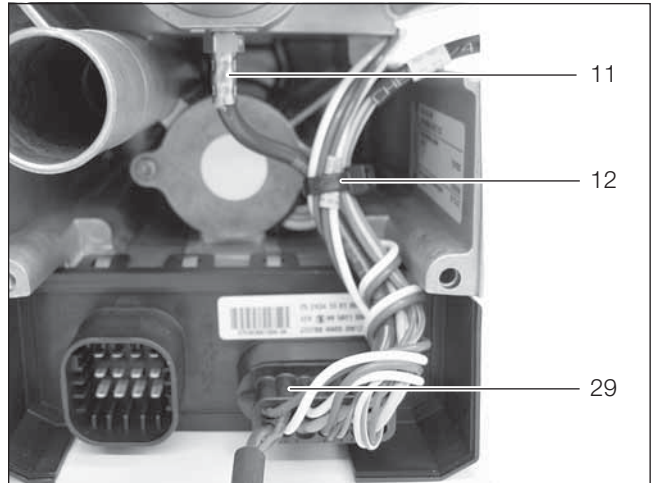

11 Flame sensor
12 Cable tie
29 14-pin connector

Figure 9

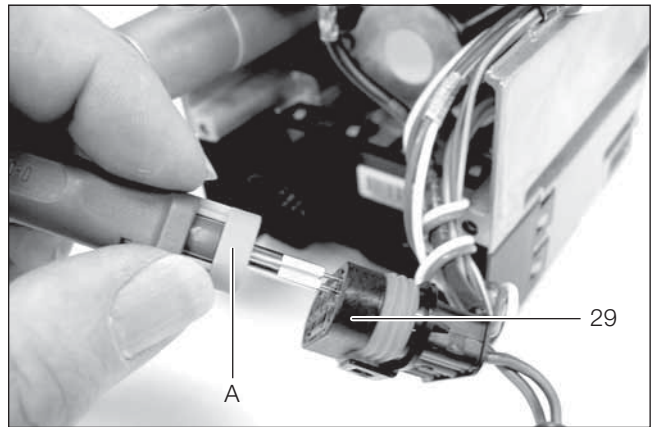

A AMP release tool
29 14-pin connector

Figure 10

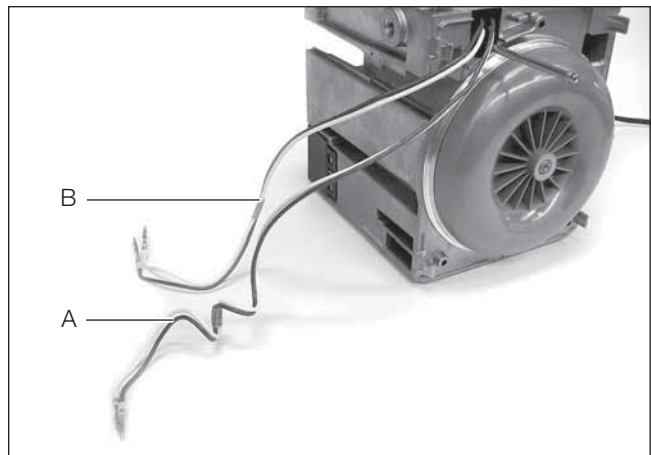

A Glow plug leads br/ws, glow plug 1 (with excess length, due to different installation positions of the glow plugs)
B Glow plug leads br/ws, glow plug 2

Figure 11

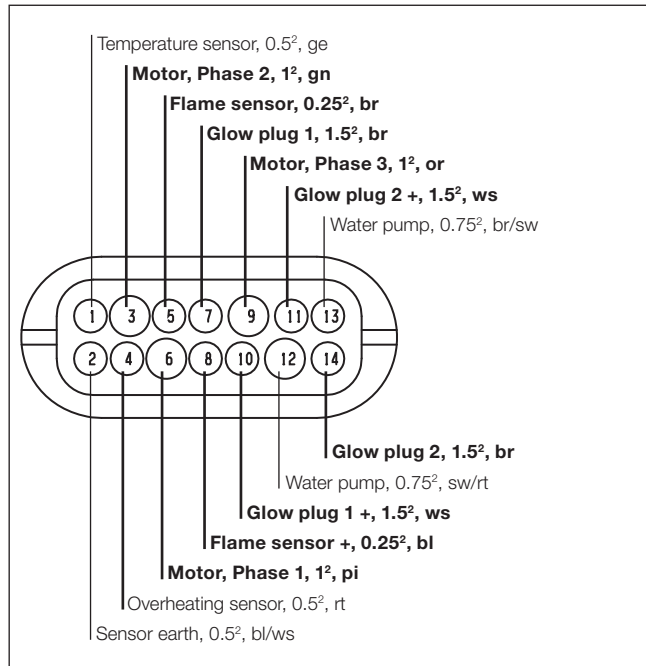

Sketch 1



5 Repair instructions

Repair step 1 Control box / blower unit and jacket

Remove flame sensor

Figure 12

- Unscrew the flame sensor (11) from the housing of the control box / blower unit.
If a special washer (30) was used for the installation of the flame sensor, it must be kept for the assembly.

Please note!

The special washer is absolutely necessary for a control box / blower unit **without** strengthening flange.

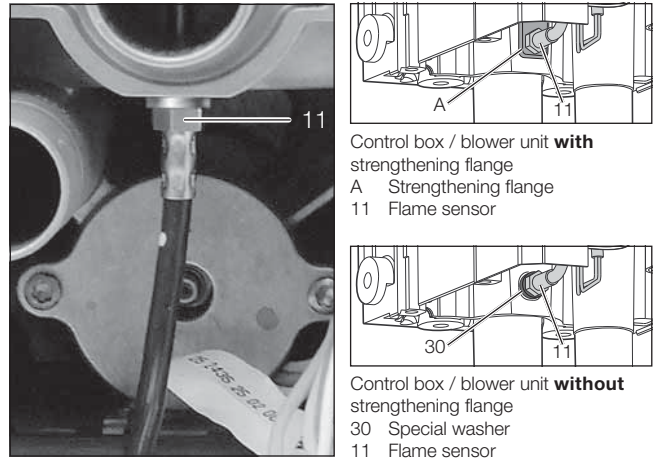

11 Flame sensor

Figure 12

Dismantle combustion chamber

Figure 13 and 14

- Undo the 3 screws (9) M5 x 16 of the combustion chamber (8).
- Lift the combustion chamber (8) with the fuel pipe until the grommet (22) is exposed, then remove the combustion chamber.
- Remove combustion chamber seal (23).

Please note!

Remove combustion chamber seal (23) without leaving residues.

Always check the glow plugs during this repair step, see repair step 3.

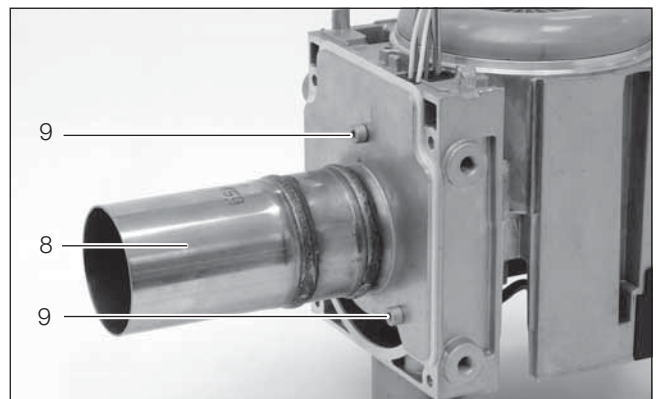

8 Combustion chamber
9 M5 x 16 screw (3 screws)

Figure 13

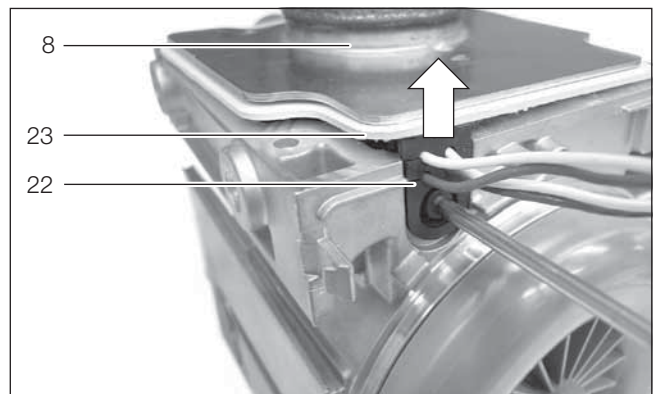

8 Combustion chamber
22 Grommet
23 Combustion chamber seal

Figure 14

5 Repair instructions

Repair step 2

Assemble control box / blower unit and jacket

Install combustion chamber seal

Figure 15 and 16

- Carefully guide the combustion chamber seal (23) over the glow plug leads and over the fuel pipes and position on the combustion chamber (8).

Please note!

Take care when installing the new combustion chamber seal (23) as there is a risk of breaking it.

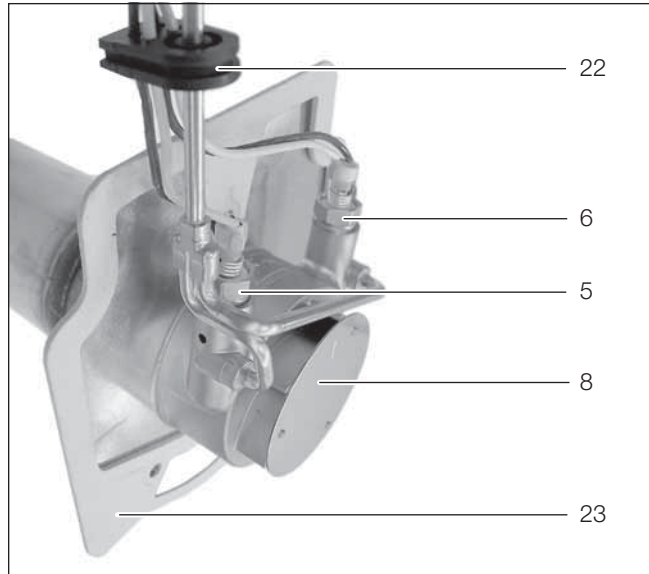

- 5 Glow plug 1
- 6 Glow plug 2
- 8 Combustion chamber
- 22 Grommet
- 23 Combustion chamber seal

Figure 15

Install grommet

Figure 16 and 17

- Carefully position the grommet (22) on the combustion chamber seal (23).

Please note!

Ensure the grommet is installed in the correct position, see Figure 17.

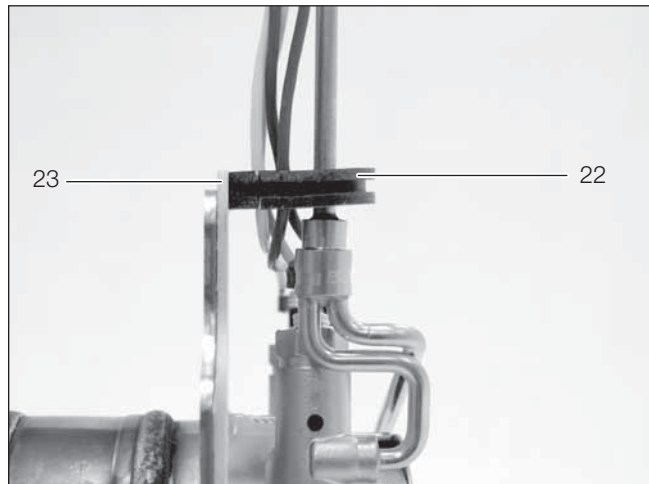

- 22 Grommet
- 23 Combustion chamber seal

Figure 16

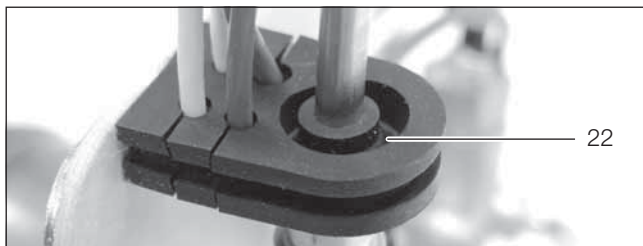

- 22 Grommet, correct position
The large opening of the grommet at the fuel tube must be visible from above

Figure 17

Insert combustion chamber

Figure 18

- First insert the combustion chamber (8) with the grommet (22) into the control box / blower unit (10). If the grommet (22) has been completely inserted, align the combustion chamber and combustion chamber seal with the control box / blower unit (10).

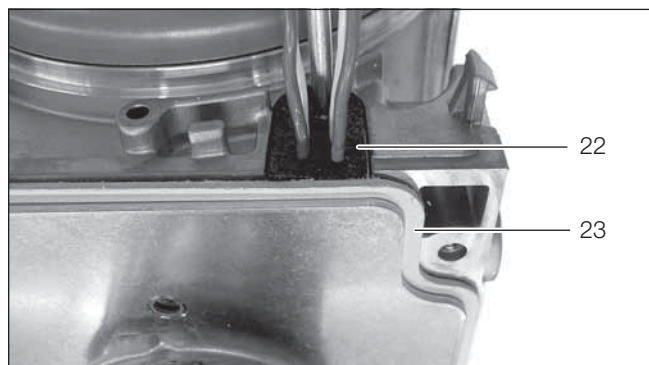

- 22 Grommet
- 23 Combustion chamber seal

Figure 18



5 Repair instructions

Repair step 2 Assemble the control box / blower unit and jacket

Install combustion chamber

Figure 19

- Use 3 screws (9) M5 x 16 to fix the combustion chamber (8).

Tightening torque M5 x 16 screw: $6^{+0.5}$ Nm

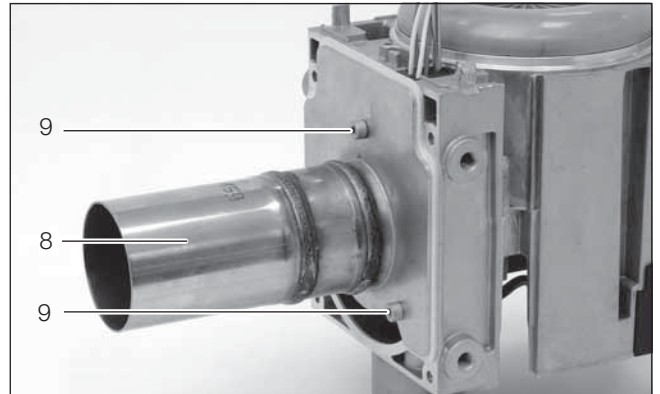

8 Combustion chamber
9 M5 x 16 screw (3 screws)

Figure 19

Lay sensor cable harness and glow plug leads

Figure 15, 20 und 21

- Lay the sensor cable harness (19) in the side cable duct first, then lay the 4 glow plug leads of glow plugs 1 (5) and 2 (6) in the cable duct.
Lay the sensor lead harness (19) and the glow plug leads to the 14-pin connector (29).
- Position the side cover (3) on the middle of the control box / blower unit (10) and push into the cable duct guide.

Please note!

It is imperative to keep to the correct laying order for the sensor lead harness (19) and the glow plug leads.

The glow plug leads may not be laid underneath the sensor lead harness (19).

The sensor lead harness (19) must be laid in the area of the fuel pipe as shown in Figure 20.

The side cover (3) is conical at the bottom to simplify installation.

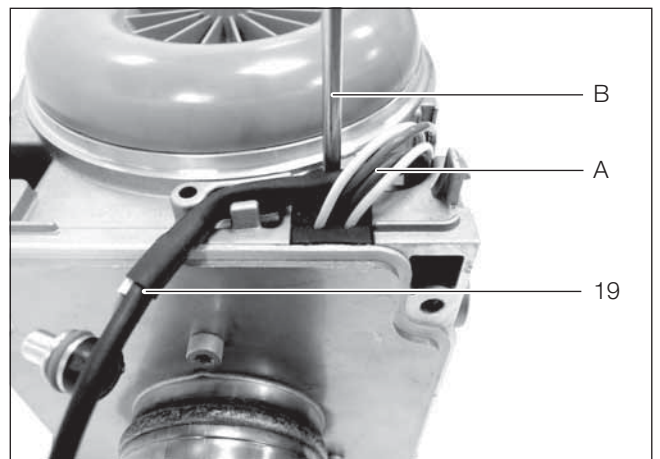

A Glow plug leads of glow plugs 1 (5) and 2 (6)
B Fuel pipe
19 Sensor cable loom

Figure 20

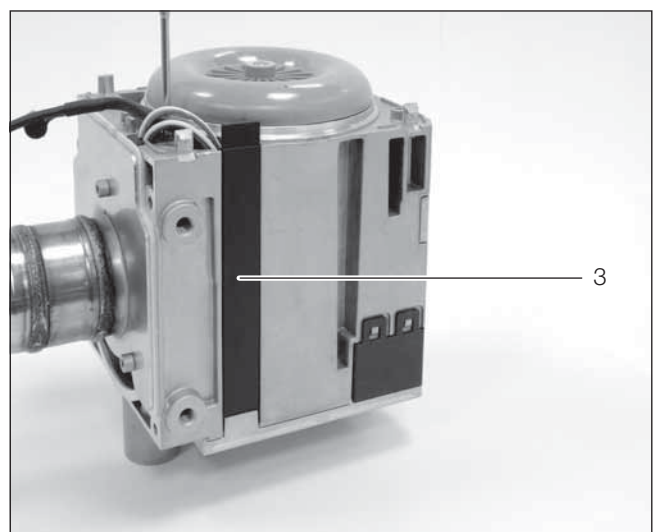

3 Cover, side

Figure 21

5 Repair instructions

Repair step 2 Assemble the control box / blower unit and jacket

Install flame sensor

Figure 22



Caution!

Before installing the new flame sensor, check whether there is a strengthening flange on the control box / blower unit housing,

- if NO, mount the flame sensor using the special washer 6.4 x 11 x 3.2 mm. Flame sensor kit with special washer 6.4 x 11 x 3.2 mm, Order No. 25 1920 36 01 00
- if YES, mount the flame sensor without the special washer 6.4 x 11 x 3.2 mm.

- Screw the flame sensor (11) into the housing of the control box / blower unit.

Flame sensor tightening torque: 2.5^{+0.5} Nm.

Connect flame sensor lead harness and electric motor leads

Figure 23 / Sketch 2

- Latch the flame sensor lead harness (11) and the three leads of the electric motor into position in the 14-pin connector (29).

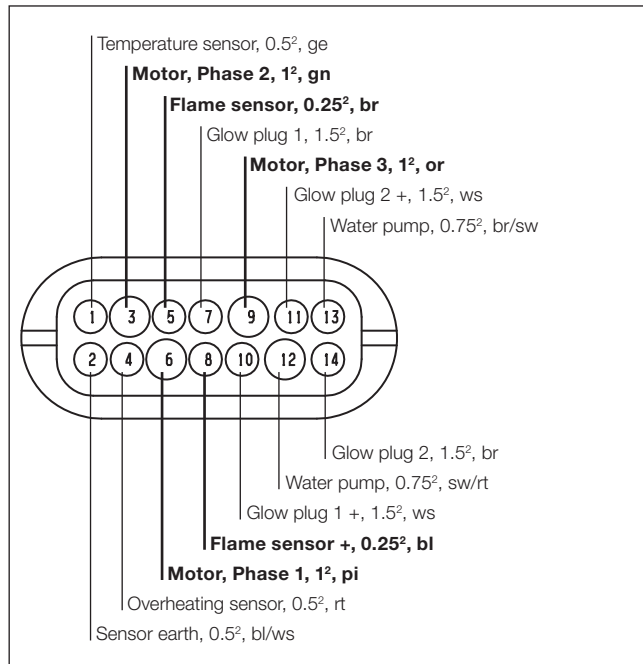

Sketch 2

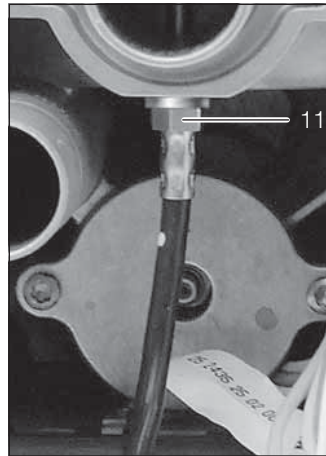

11 Flame sensor

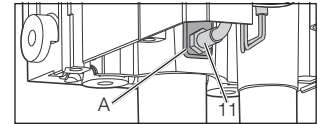

Control box / blower unit **with**
strengthening flange
A Strengthening flange
11 Flame sensor

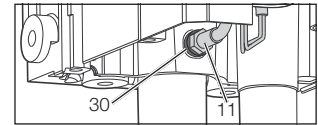

Control box / blower unit **without**
strengthening flange
30 Special washer
11 Flame sensor

Figure 22

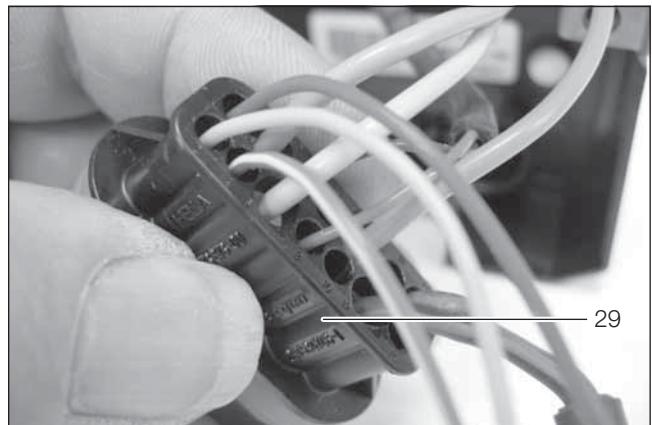

29 14-pin connector

Figure 23

Please note!

- The leads may not lay against the housing.
- Always lay the br/ws (long) leads of glow plug 1 (5) last and latch into position in the 14-pin connector (29).

5 Repair instructions

Repair step 2 Assemble control box / blower unit and jacket

Connect glow plug leads

Figure 24, 25 and Sketch 3

- Latch the glow plug leads of glow plug 2 (6) into the 14-pin connector (29) first.
Then wind the glow plug leads of glow plug 1 (5) 2 x around the leads already latched into position in the 14-pin connector and then latch into position in the 14-pin connector (29).
Use a cable tie (12) to bundle all leads above the winding.
Connect the 14-pin connector (29) to the control box / blower unit.

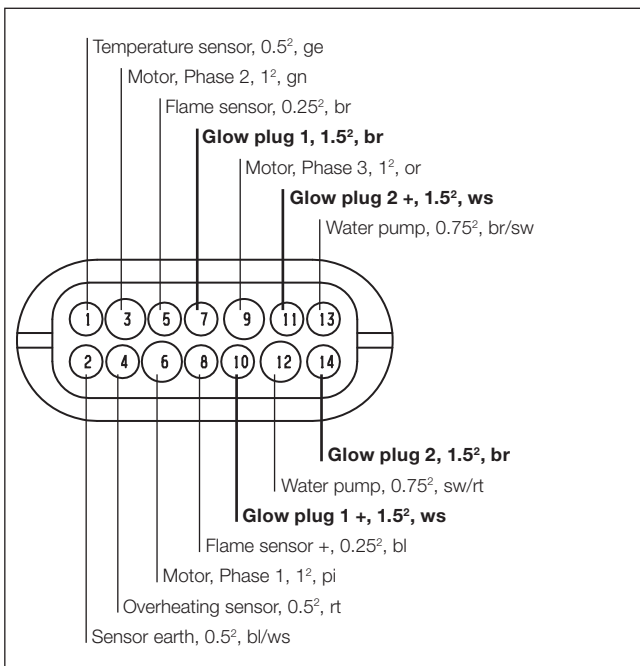

Sketch 3

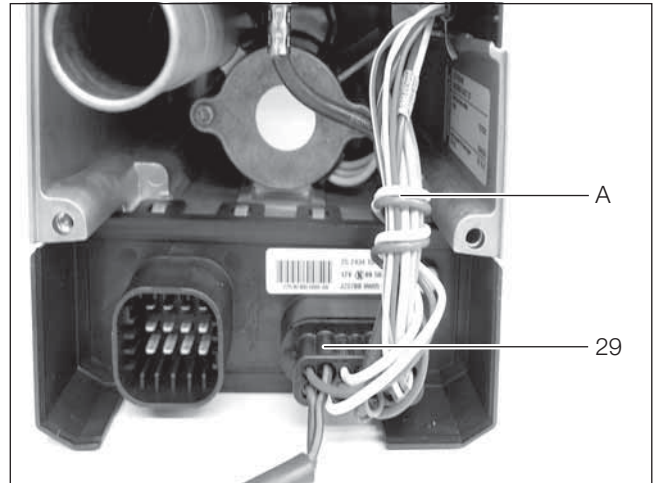

A Two windings of the glow plug leads of glow plug 1
29 14-pin connector

Figure 24

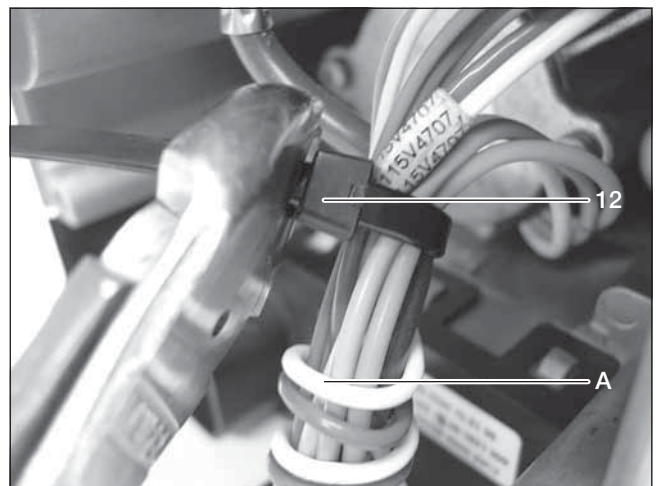

A Two windings of the glow plug leads of glow plug 1
12 Cable tie (use side cutters to shorten surplus tie length)

Figure 25

Please note!

- The different installation positions of the glow plugs results in an excess length of glow plug leads for glow plug 1 after the installation has been completed. This excess length must be removed before latching the glow plug leads into the 14-pin connector by winding it around the already latched in leads.
- The leads may not lay against the housing.
- Check the glow plugs before completely assembling the heater. For check values, see fault code 020 / 021.

5 Repair instructions

Repair step 2

Assemble control box / blower unit and jacket

Install electric motor cover

Figure 26 and 27

- Position the electric motor cover (13) on the housing of the control box / blower unit, at the same time, insert the water pump lead harness in the groove provided in the cover.
- Use 2 screws (14) M5 x 16 to fasten the electric motor cover (13) onto the housing of the control box / blower unit.

Tightening torque M5 x 16 screw: $6^{+0.5}$ Nm.

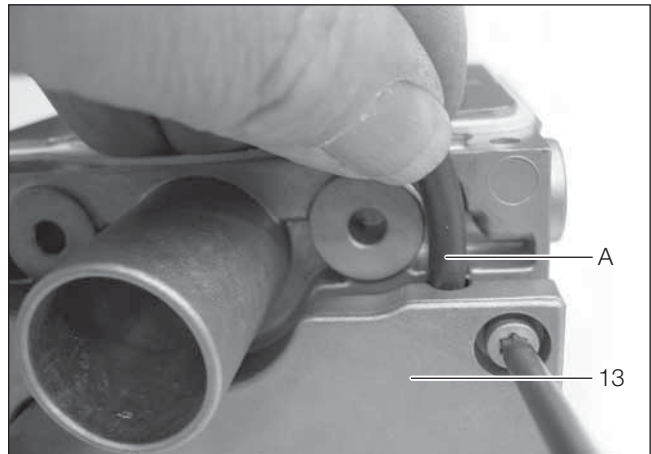

A Water pump lead harness
13 Electric motor cover

Figure 26

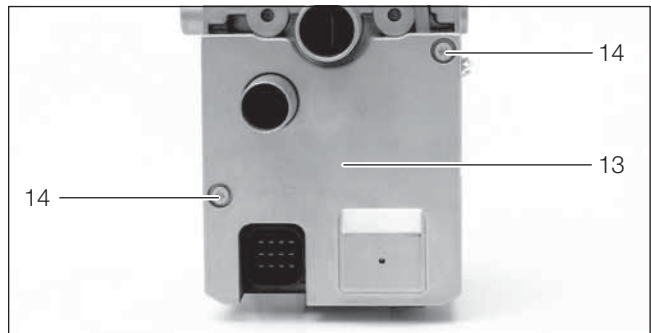

13 Electric motor cover
14 M5 x 16 screw

Figure 27

Assemble control box / blower unit and jacket

Figure 28

Position the heat exchanger on the control box / blower unit and fasten with 4 screws (21) M5 x 25.

Tightening torque M5 x 25 screw: $6^{+0.5}$ Nm.

Please note!

Tighten the 4 screws (21) M5 x 25 cross-wise (i.e. tighten diagonally opposite screws).

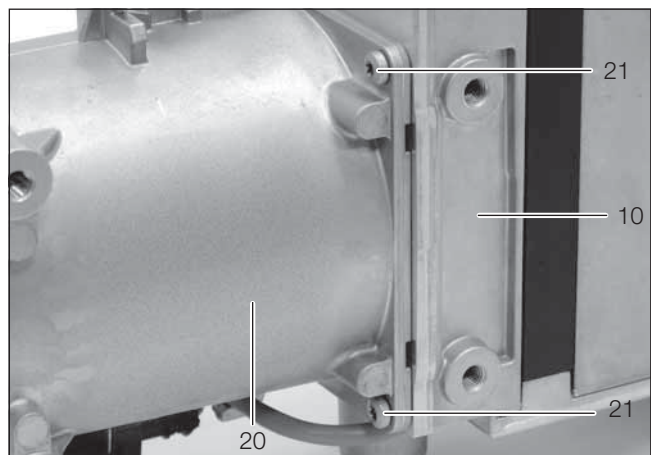

10 Control box / blower unit
20 Jacket with heat exchanger
21 M5 x 25 screw (4 screws)

Figure 28



5 Repair instructions

Repair step 2 Control box / blower unit and jacket

Lay water pump lead harness

Figure 29

- Insert the water pump lead harness into the holder on the jacket, lay up to the water pump and connect.

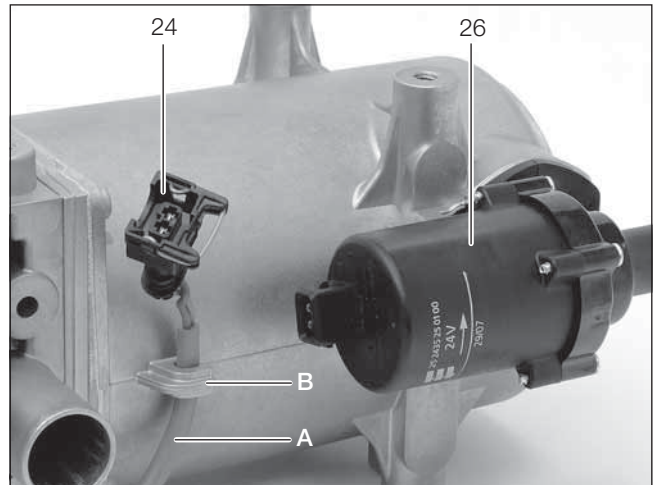

- 24 Water pump connector
- 26 Water pump
- A Water pump cable harness loom
- B Holder on jacket with heat exchanger

Figure 29

Install overheating and temperature sensor

Figure 30 and 31

- Insert the overheating (17) and temperature sensor (18) into the holders on the jacket.
Insert the sensor cable loom (19) into the holders on the jacket.
Use 2 screws (15) M4 x 12 to fasten both springs (16) on the overheating (17) and temperature sensor (18).

Tightening torque M4 x 12 screw: $3,3^{+0.5}$ Nm.

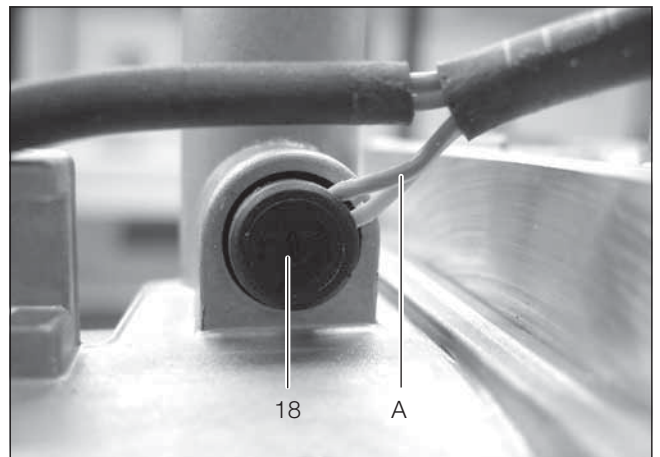

- A Correct installed position and cable routing
- 18 Temperature sensor

Figure 30

Please note!

Insert the temperature sensor as shown in the figure to avoid pinching the cable loom.

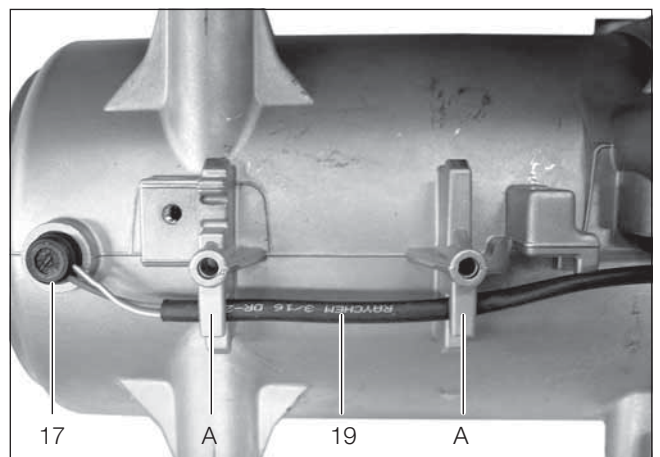

- A Holder
- 17 Overheating sensor
- 19 Sensor cable loom

Figure 31

5 Repair instructions

Repair step 2 Control box / blower unit and jacket

Install impeller cover

Figure 32

- Clamp the removed heater in a retaining device (vice) and position the new O-ring (2) on the control box / blower unit.
- Install the impeller cover; ensure that none of the leads of the sensor lead harness (19) get jammed.



2 O-Ring, positioned on the control box / blower unit

Figure 32



5 Repair instructions

Repair step 3

Remove / check glow plug

Figure 33

- Carry out repair step 1.
- Unscrew glow plugs 1 (5) and 2 (6) from the combustion chamber housing (8), if necessary check the glow plugs; for check values see fault code 020 / 021.
- Visually check the spark plug socket lining, if necessary renew the spark plug lining.

Install glow plug

Figure 33 / Sketch 4

- Screw glow plug 1 (5) into the left-hand spark plug socket (2 fuel lines).
- Screw glow plug 2 (6) into the right-hand spark plug socket (1 fuel line).
Glow plug tightening torque: $6^{+0.5}$ Nm.
- Connect glow plug leads to 14-pin connector.
Glow plug 1 (5)
 - br lead in Chamber 7
 - ws lead in Chamber 10Glow plug 2 (6)
 - br lead in Chamber 14
 - ws lead in Chamber 11

Please note!

The different installation positions of the glow plugs results in an excess length of glow plug leads for glow plug 1 after the installation has been completed.

- Assemble the heater according to repair step 2.

Characteristics of the glow plugs

12 volt glow plug

– green banderole around the br and ws leads

24 volt glow plug

– yellow banderole around the br and ws leads

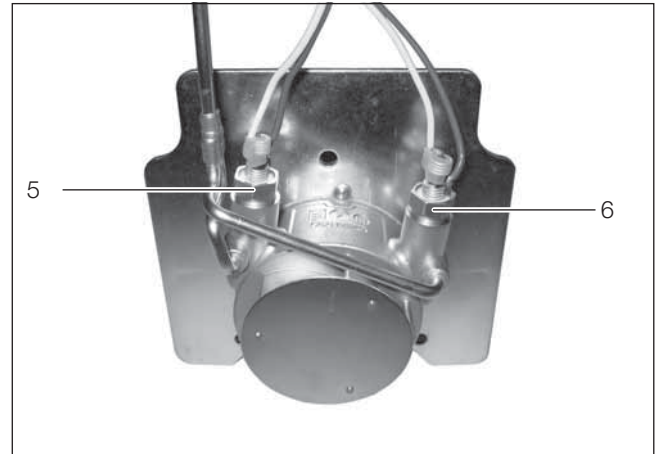

5 Glow plug 1 installed in left-hand spark plug socket
6 Glow plug 2 installed in right-hand spark plug socket

Figure 33

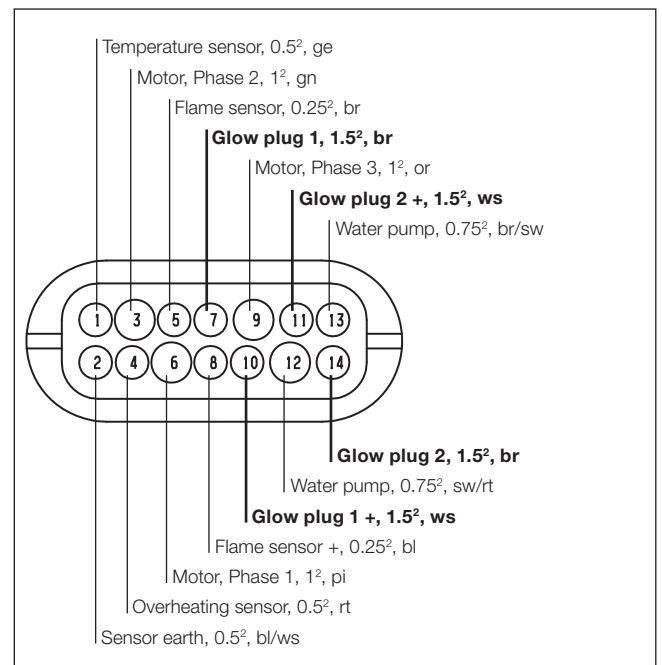

Sketch 4

Clean ignition air drillholes

Figure 34

- Use a pointed object to clean the ignition air drillholes in the left-hand and right-hand spark plug sockets.

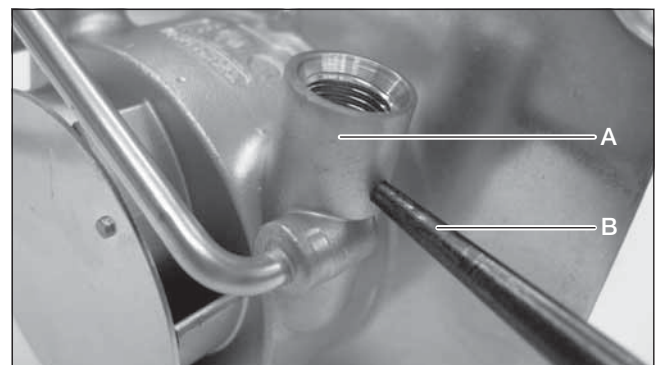

A Right-hand spark plug socket
B Pointed object for cleaning the ignition air drillhole.

Figure 34

5 Repair instructions

Repair step 4

Remove spark plug socket lining

Figure 35

- Carry out repair step 1.
- Unscrew glow plugs from the combustion chamber housing (8).
- Use a pointed object to pull the spark plug socket lining out of the spark plug socket.

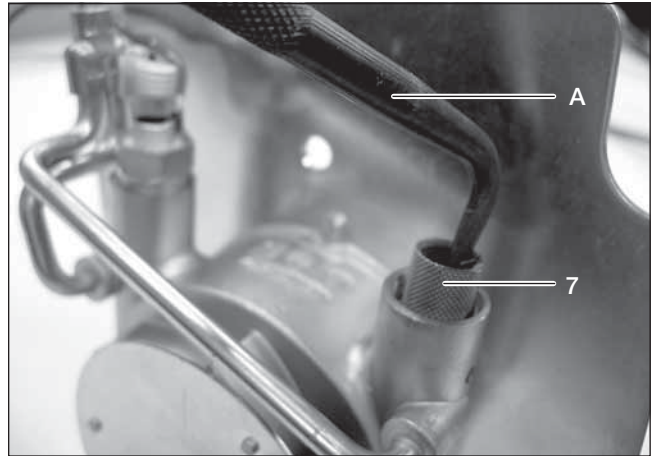

A Pointed object for pulling out the lining
7 Spark plug socket lining

Figure 35

Install spark plug socket lining

Figure 36, 36/1

- Insert the spark plug socket lining in the spark plug socket with the bevelled edge facing upwards and use the assembly tool to press it in up to the limit stop.

Please note!

Ensure the ignition air drillhole in the spark plug socket is not concealed by the spark plug socket lining.

- Assemble the heater according to repair step 2.

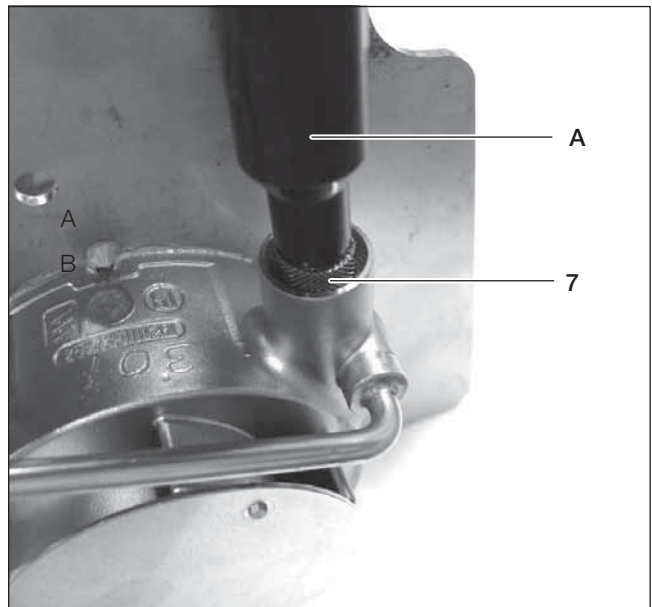

7 Spark plug socket lining
28 Assembly tool

Figure 36

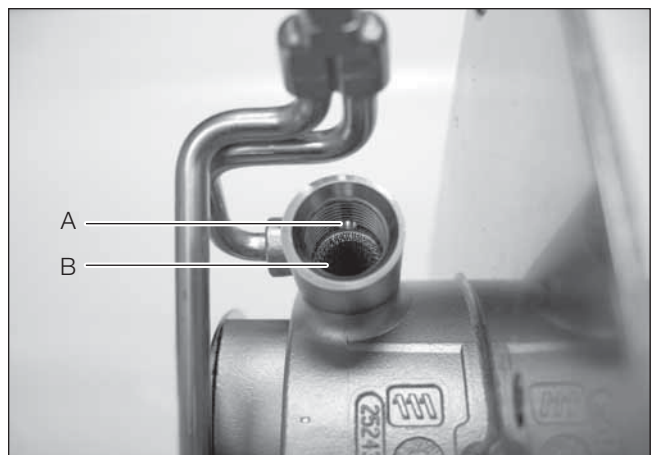

A Ignition air drillhole
B Spark plug socket with lining installed

Figure 36/1

5 Repair instructions

Repair step 5

Check overheating and temperature sensor

Figure 37 / Diagram 1

- Removal of the overheating (17) and temperature sensor (18) is described in repair step 1.
- Use the digital multimeter to check the overheating (17) and temperature sensor (18).
If the resistance value lies outside the table of values or the diagram, then replace the overheating (17) and temperature sensor (18).
- Installation of the overheating (17) and temperature sensor (18) is described in repair step 2.

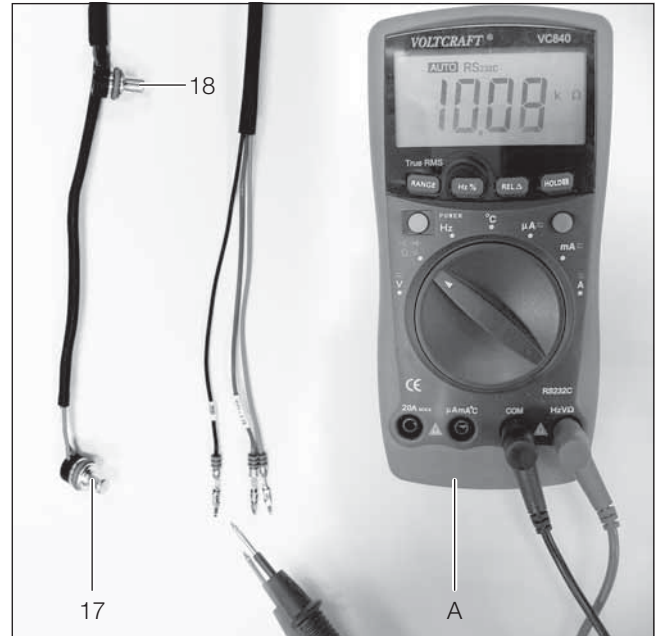

A Digital multimeter
17 Overheating sensor
18 Temperature sensor

Figure 37

Table of values

Temp[°C]	0	25	40	60	80	100	120
R_{NTC} [k Ω]	32.55	10	5.33	2.49	1.26	0.677	0.389

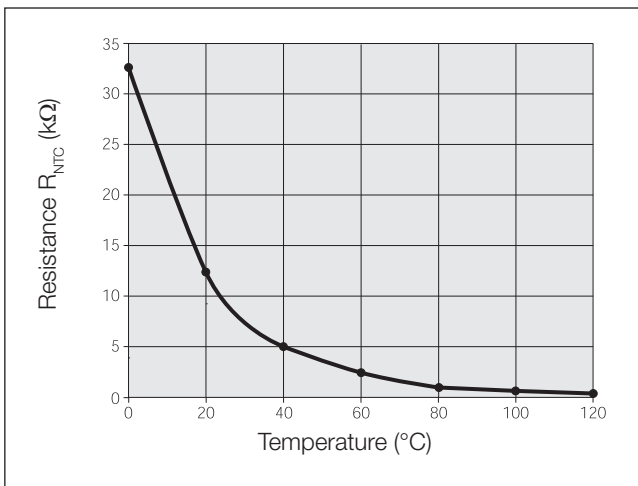

Diagram 1

5 Repair instructions

Repair step 6

Check flame sensor

Figure 38 / Diagram 2

- Removal of the flame sensor (11) is described in repair step 1.
- Use the digital multimeter to check the flame sensor (11). If the resistance value lies outside the table of values or the diagram, then replace the flame sensor (11).
- Installation of the flame sensor (11) is described in repair step 2.

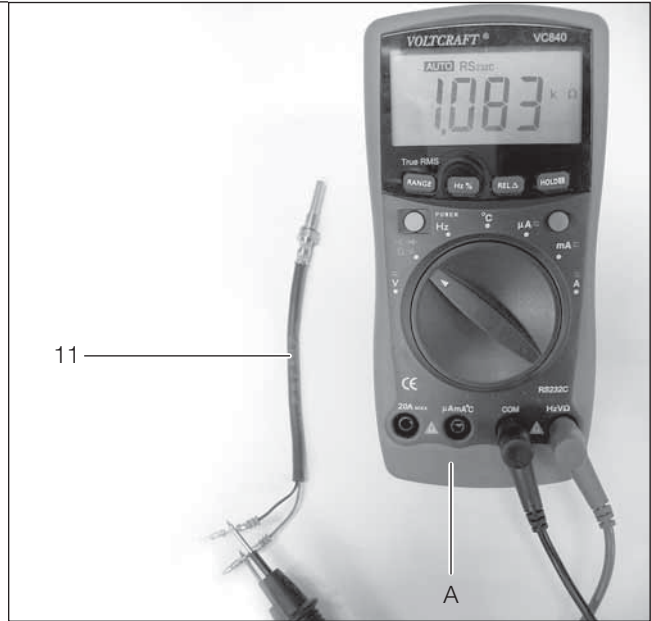

A Digital multimeter
11 Flame sensor

Figure 38

Table of values

Temp[°C]	-50	0	50	100	150	200	250	300	350	400
R [Ω]	803	1000	1194	1385	1573	1758	1941	2120	2297	2470

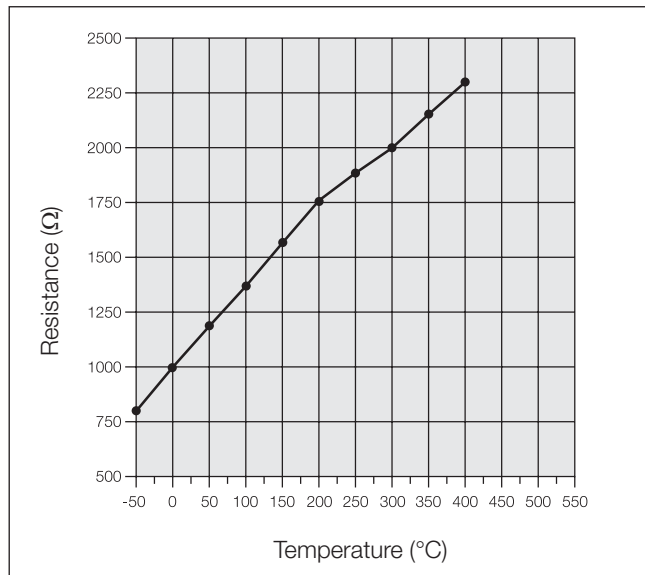

Diagram 2



5 Repair instructions

Repair step 7

Remove / attach water pump

Figure 39

- Disconnect the connector (24) at the water pump (26).
- Undo the hose clip (25)
- Remove the water pump.
- Check O-ring (27), replace if necessary
- Install in the reverse order.

Hose clip tightening torque: $3^{+0.5}$ Nm.

Please note!

When assembling the O-ring (28) coat it with lubricant, e.g. Hellerine

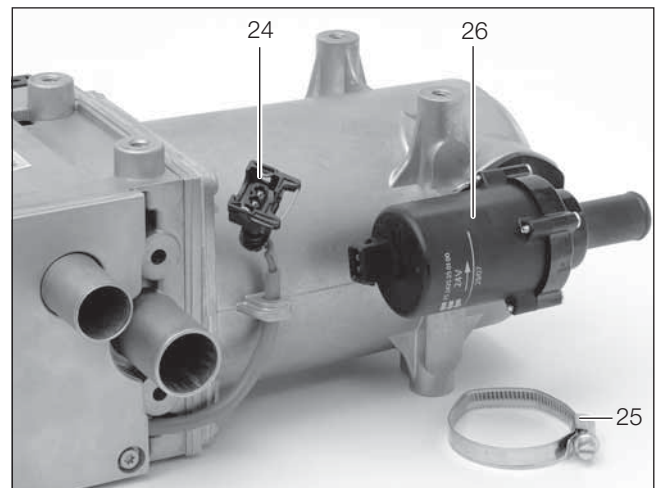

- 24 Water pump connector
- 25 Hose clip
- 26 Water pump

Figure 39

5 Repair instructions

Measuring the fuel quantity

Preparing for the measurement

(Sketch 5)

- Disconnect the fuel pressure line at the heater and place the end in a measuring cylinder (size 25 cm³).
- Switch on the heater, if the fuel discharges uniformly and free of bubbles, the fuel pipe is filled and vented.
- Switch off heater and empty measuring cylinder.

Measurement

- Switch on heater and wait until the metering pump starts pumping the fuel.
- During the measurement, hold the measuring cylinder at the level of the heater.
After 68 sec. the pumping of the fuel is automatically switched off.
- Switch off heater, as otherwise it will start up again.
- Read off the quantity of fuel in the measuring cylinder.

Evaluation

Compare the measured quantity of fuel with the values in the following table.

If the measured quantity of fuel is above the maximum value or below the minimum value, the metering pump must be replaced.

Heater	Quantity of fuel		
	Desired	Maximum	Minimum
Hydronic M8 Diesel / FAME	5.7 cm ³ / 68 sec	6.27 cm ³ / 68 sec	5.13 cm ³ / 68 sec
Hydronic M10 Diesel	7.5 cm ³ / 68 sec	8.25 cm ³ / 68 sec	6.75 cm ³ / 68 sec
Hydronic M12 Diesel	7.5 cm ³ / 68 sec	8.25 cm ³ / 68 sec	6.75 cm ³ / 68 sec

Please note!

Only carry out the fuel measurement if the battery is sufficiently charged. During the measurement the voltage applied to the box should be at least 11 volt or 23 volt and max. 13 volt or 25 volt.

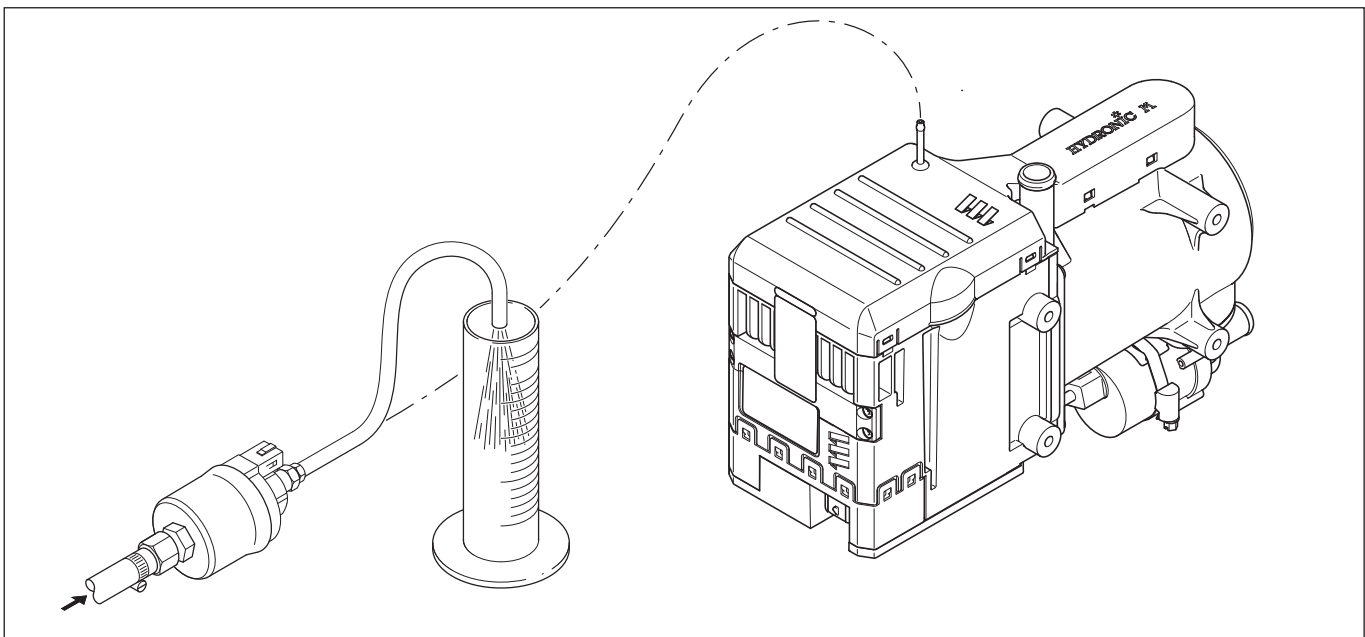

Sketch 5

6 Circuit diagram



Heater wiring

The heater is to be connected up electrically according to the EMC directives.



Caution!

Safety instructions for wiring the heater!

EMC can be affected if the heater is not connected up correctly. For this reason, comply with the following instructions:

- Ensure that the insulation of electrical cables is not damaged. Avoid: chafing, kinking, jamming or exposure to heat.
- In waterproof connectors, seal any connector chambers not in use with filler plugs to ensure they are dirt-proof and water-proof.
- Electrical connections and ground connections must be free of corrosion and firmly connected.
- Lubricate connections and ground connections outside the heater interior with contact grease.

Please note!

Comply with the following when wiring the heater and the control unit:

- Electrical leads, switch and control gear must be positioned in the vehicle so that they can function perfectly under normal operating conditions without impairment (e.g. due to heat exposure, moisture, etc.).
- The following cable cross sections are to be used between the battery and heater.
This ensures that the max. allowable voltage drop in the cables does not exceed 0.5 V for 12 V or 1 V for 24 V rated voltage.
Cable cross-sections for a cable length (plus cable + minus cable) of:
 - up to 5 m = cable cross-section 4 mm²
 - from 5 m up to 8 m = cable cross-section 6 mm²
 Connection of the cables (plus cable and minus cable) to connector B2 requires a reduction in the cable cross-section to 2.5 mm².
- If the positive cable is to be connected to the fuse box (e.g. terminal 30), the vehicle's cable from the battery to the fuse box must also be included in the calculation for the total cable length and re-dimensioned if necessary.
- Insulate unused cable ends.

Notes on rewiring the 12-pin cable harness connector

If, when replacing the Hydronic M with the Hydronic M-II, the cable harness installed in the vehicle is retained and continues to be used, it is necessary to remove the 12-pin connector using the AMP release tool (AMP Order No. 1-1579007-4) and to rewire it according to the following table.

12-pin cable harness connector

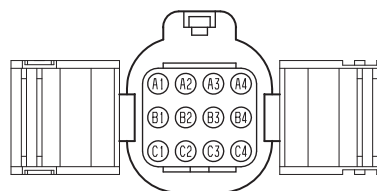

Connector is shown from the lead entry side.

Connection	Cable harness Hydronic M Cross-section Cable colour	Rewiring 12-pin connector	
		Hydronic M PIN	Hydronic M-II PIN
Metering pump	1.5 ² gn	C4 →	A1
Terminal 31	4 ² br	C3 →	A2*
Terminal 30	4 ² rt	C2 →	A3*
Plus signal to the battery power switch	1.5 ² ws/rt	C1 →	A4
Plus signal to the relay solenoid valve	–	B4 →	B1
Diagnosis	1 ² bl	B3 →	B4
Plus signal from the ADR auxiliary drive	1 ² vi	B2 →	B3
Third party control Water pump	–	B1 →	remains unused**
Blower relay	1 ² rt/ge	A4 →	C1
Plus signal (D+) to the heater – in ADR mode	1 ² vi/gn	A3 →	C2
Temperature drop	–	A2 →	C3
Heater ON	1 ² ge	A1 →	C4

* Connection of the cables to connector B2 requires a reduction in the cable cross-section to 2.5 mm².

** Third party control of the water pump is not provided for in the Hydronic M-II.

6 Circuit diagram

Circuit diagram: Hydronic M-II – 12 volt / 24 volt

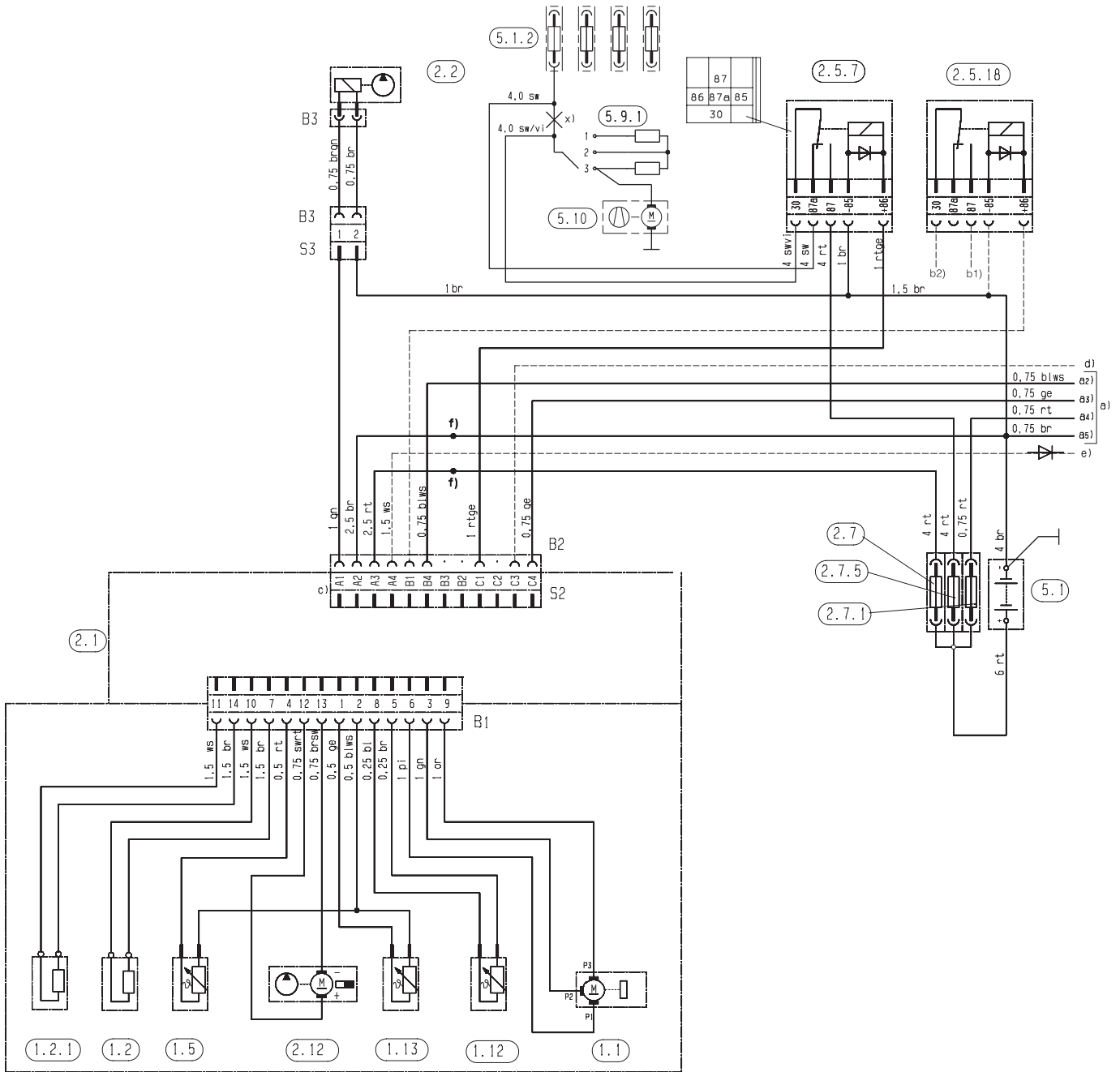

- a) 0.75 blws d1
- a2) 0.75 ge
- a3) 0.75 rt
- a4) 0.75 br
- a5) 0.75 br
- e)

B1

B2

B3

B4

S2

S3

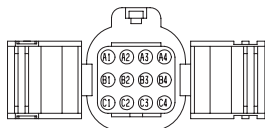
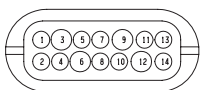



6 Circuit diagram

Parts list for circuit diagram: Hydronic M-II 12 volt / 24 volt

- 1.1 Burner motor
- 1.2 Glow plug 1
- 1.2.1 Glow plug 2 (optionally 12 kW / FAME)
- 1.5 Overheating sensor
- 1.12 Flame sensor
- 1.13 Temperature sensor

- 2.1 Control box
- 2.2 Metering pump
- 2.5.7 Relay, for control of vehicle fan
- 2.5.18 Relay, for control of electrical solenoid valve in the water circuit – optional
- 2.7 Main fuse 12 volt = 25 A
24 volt = 15 A
- 2.7.1 Fuse, actuation 5 A
- 2.7.5 Fuse, vehicle fan 25 A
- 2.12 Water pump

- 5.1 Battery
- 5.1.2 Fuse block in the vehicle
- 5.9.1 Switch, vehicle blower
- 5.10 Vehicle fan

- a) Connection, control units
 - a2) Diagnosis
 - a3) Switch-on signal S+
 - a4) Power supply, positive (+) terminal 30
 - a5) Power supply, minus (-) terminal 31
 - EasyStart R+ / R / T: use the 0.752 bl/ws cable, 12-pin connector B2, PIN B4
 - Use the 0.752 ge cable, 12-pin connector B2, PIN C4 for all other control units
- b1) Plus signal for electric solenoid valve
- b2) (+) Terminal 30 via fuse for relay 2.5.18
- c) Heater connection

Connector pin assignment: 12-pin connector B2 (external)

PIN No.	Connection	Lead cross-section mm ²
A1	Metering pump	1.5
B1	Solenoid valve, optional	1.0
C1	Blower relay	1.0
A2	Terminal 31	4.0 / 2.5 for the connection at connector B2
B2	Diagnosis (OEM)	1.0
C2	unused	–
A3	Terminal 30	4.0 / 2.5 for the connection at connector B2
B3	unused	–
C3	Temperature drop	1.0
A4	Plus signal output	1.5
B4	Diagnosis (HELJED)	1.0
C4	Heater ON	1.0

- d) Temperature lowering of the control stages by 7 °C, switching on and off temperature of the vehicle fan by 10 °C with plus signal at PIN C3.
- e) (+) Control battery disconnecting switch (diode: order no. 208 00 012)
- f) Only 2.5 mm² cables with appropriate individual core sealing may be installed in PIN A2 and A3 from 12-pin connector B2.
If a 4 mm² or 6 mm² cable is used, a 100 mm to 200 mm long 2.5 mm² cable must be welded onto its end and insulated watertight.
- x) Disconnect cable

Please note!

- In 12 V relay 2.5.7 (from terminal 30 to terminal 87a), a maximum power consumption of 40 A is allowed; i.e. the value of the vehicle's own fan fuse may not be >40 A.
- Connectors and bush housings are shown from the cable inlet side.
- See page 42 for circuit diagram.

Cable colours

- rt = red
- bl = blue
- ws = white
- sw = black
- gn = green
- gr = grey
- ge = yellow
- vi = violet

6 Circuit diagram

Circuit diagram: Hydronic M-II, 12 volt / 24 volt, ADR

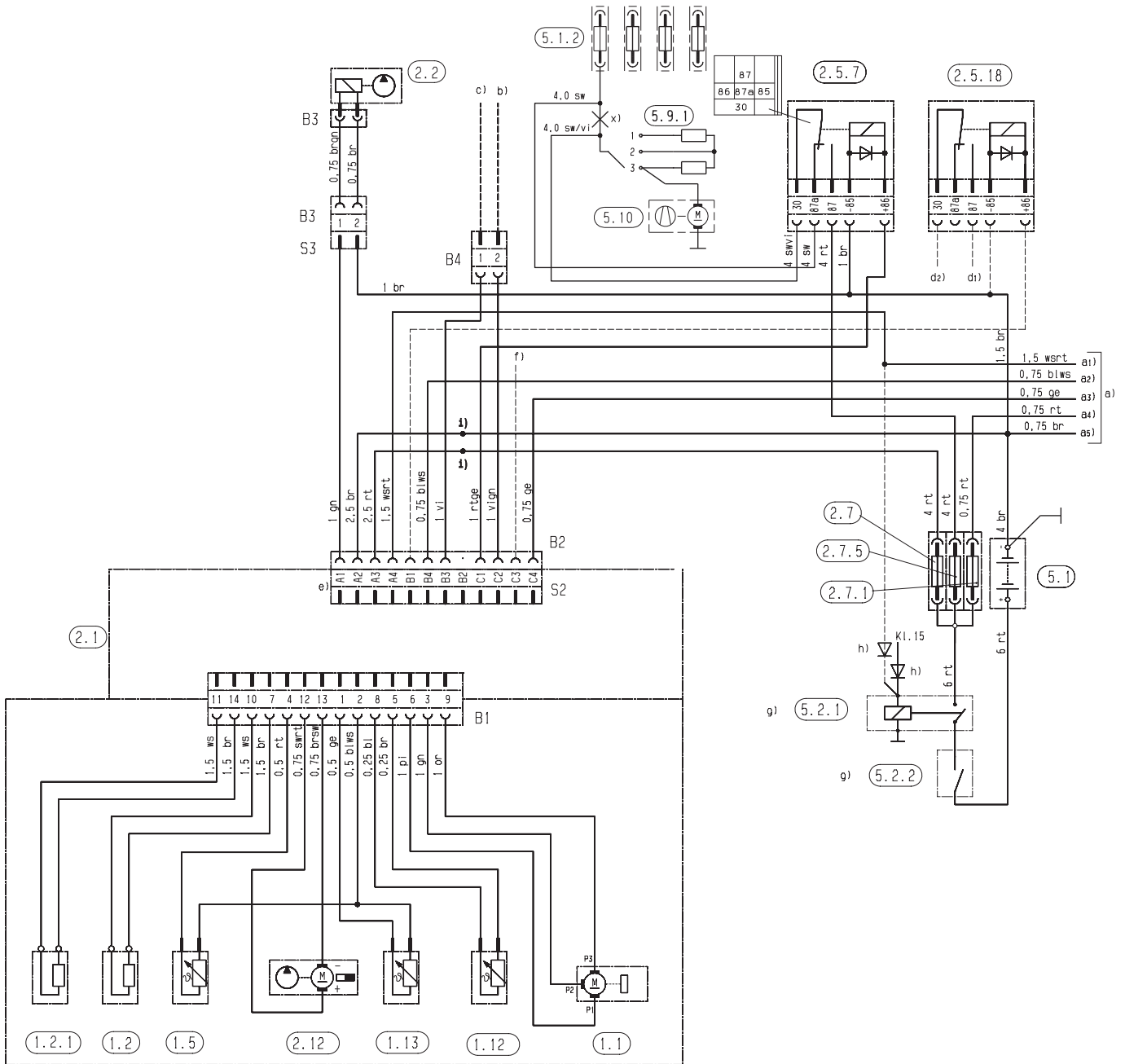

B1

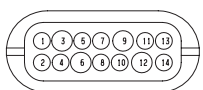

B2

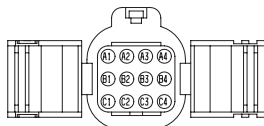

B3



B4



S2



S3





6 Circuit diagram

Parts list for circuit diagram: Hydronic M-II, 12 volt / 24 volt, ADR

- 1.1 Burner engine
- 1.2 Glow plug 1
- 1.2.1 Glow plug 2
- 1.5 Overheating sensor
- 1.12 Flame sensor
- 1.13 Temperature sensor

- 2.1 Control box
- 2.2 Metering pump
- 2.5.7 Relay, for control of vehicle fan
- 2.5.18 Relay, for control of electrical solenoid valve in the water circuit – optional
- 2.7 Main fuse 12 volt = 25 A
24 volt = 15 A
- 2.7.1 Fuse, actuation 5 A
- 2.7.5 Fuse, vehicle fan 25 A
- 2.12 Water pump

- 5.1 Battery
- 5.1.2 Fuse block in the vehicle
- 5.9.1 Switch, vehicle blower
- 5.10 Vehicle fan

- a) Connection, control units
 - a1) ADR feedback
 - a2) Diagnosis
 - a3) Switch-on signal S+
 - a4) Power supply, positive (+) terminal 30
 - a5) Power supply, minus (-) terminal 31
 - EasyStart R+ / R / T: use the 0.752 bl/ws cable, 12-pin connector B2, PIN B4
 - Use the 0.752 ge cable, 12-pin connector B2, PIN C4 for all other control units
- b) For ADR D+ (dynamo)
- c) For ADR HA+ (auxiliary drive/ secondary drive) minus circuit, if not present, route lead to +
- d1) Plus signal for electric solenoid valve
- d2) (+) Terminal 30 via fuse for relay 2.5.18
- e) Heater connection

Connector pin assignment: 12-pin connector (external)

PIN No.	Connection	Lead cross-section mm ²
A1	Metering pump	1.5
B1	Solenoid valve, optional	1.0
C1	Blower relay	1.0
A2	Terminal 31	4.0 / 2.5 for the connection at connector B2
B2	Diagnosis (OEM)	1.0
C2	unused	–
A3	Terminal 30	4.0 / 2.5 for the connection at connector B2
B3	unused	–
C3	Temperature drop	1.0
A4	Plus signal output	1.5
B4	Diagnosis (HELJED)	1.0
C4	Heater ON	1.0

- f) Temperature lowering of the control stages by 7 °C, switching on and off temperature of the vehicle fan by 10 °C with plus signal at PIN C3.
- g) If only one switching element is used for Item 5.2.1 and 5.2.2, it is important to ensure that on activating the battery disconnecting switch (EMERGENCY OFF function in ADR), the switch always breaks contact (opens) immediately (regardless of the heater condition) and all the heater's electric circuits are disconnected from the battery.
- h) (+) Trigger battery isolating switch (Diode: Order No. 208 00 012)
- i) Only 2.5 mm² cables with appropriate individual core sealing may be installed in PIN A2 and A3 from 12-pin connector B2.
If a 4 mm² or 6 mm² cable is used, a 100 mm to 200 mm long 2.5 mm² cable must be welded onto its end and insulated watertight.
- x) Disconnect cable

Please note!

- In 12 V relay 2.5.7 (from terminal 30 to terminal 87a), a maximum power consumption of 40 A is allowed; i.e. the value of the vehicle's own fan fuse may not be >40 A.
- Connectors and bush housings are shown from the cable inlet side.
- See page 44 for circuit diagram.

Cable colours

- rt = red
- bl = blue
- ws = white
- sw = black
- gn = green
- gr = grey
- ge = yellow
- vi = violet

6 Circuit diagram

Parts list for circuit diagrams, control units: EasyStart R+ / R / T and EasyStart T – ADR

- 2.15.1 Temperature sensor (room temperature)
(included in scope of supply for EasyStart R+,
optional for EasyStart R and EasyStart T)
- 2.15.9 Temperature sensor (outside temperature)

- 3.1.7 "ON / OFF" button
- 3.1.16 Radio remote control button

- 3.2.15 EasyStart T timer

- 3.3.9 Radio remote control, EasyStart R (stationary unit)
- 3.3.10 Radio remote control, EasyStart R+ (stationary unit)

- 3.6.1 Adapter cable

- 3.8.3 Antenna

- c) Terminal 58 (lighting)
- e) Connection, EasyStart T timer
- g) External "ON / OFF" button (optional)
- x) ADR jumper

- Insulate unused cable ends.
- Connectors and bush housings are shown from the cable inlet side.

Cable colours

- rt = red
- bl = blue
- ws = white
- sw = black
- gn = green
- gr = grey
- ge = yellow
- vi = violet

Please note!

- | | |
|-----------------------------------|-------------|
| EasyStart R+ circuit diagram | see page 47 |
| EasyStart R circuit diagram | see page 48 |
| EasyStart T circuit diagram | see page 49 |
| EasyStart T – ADR circuit diagram | see page 50 |



6 Circuit diagram

Circuit diagram for EasyStart R+ control unit

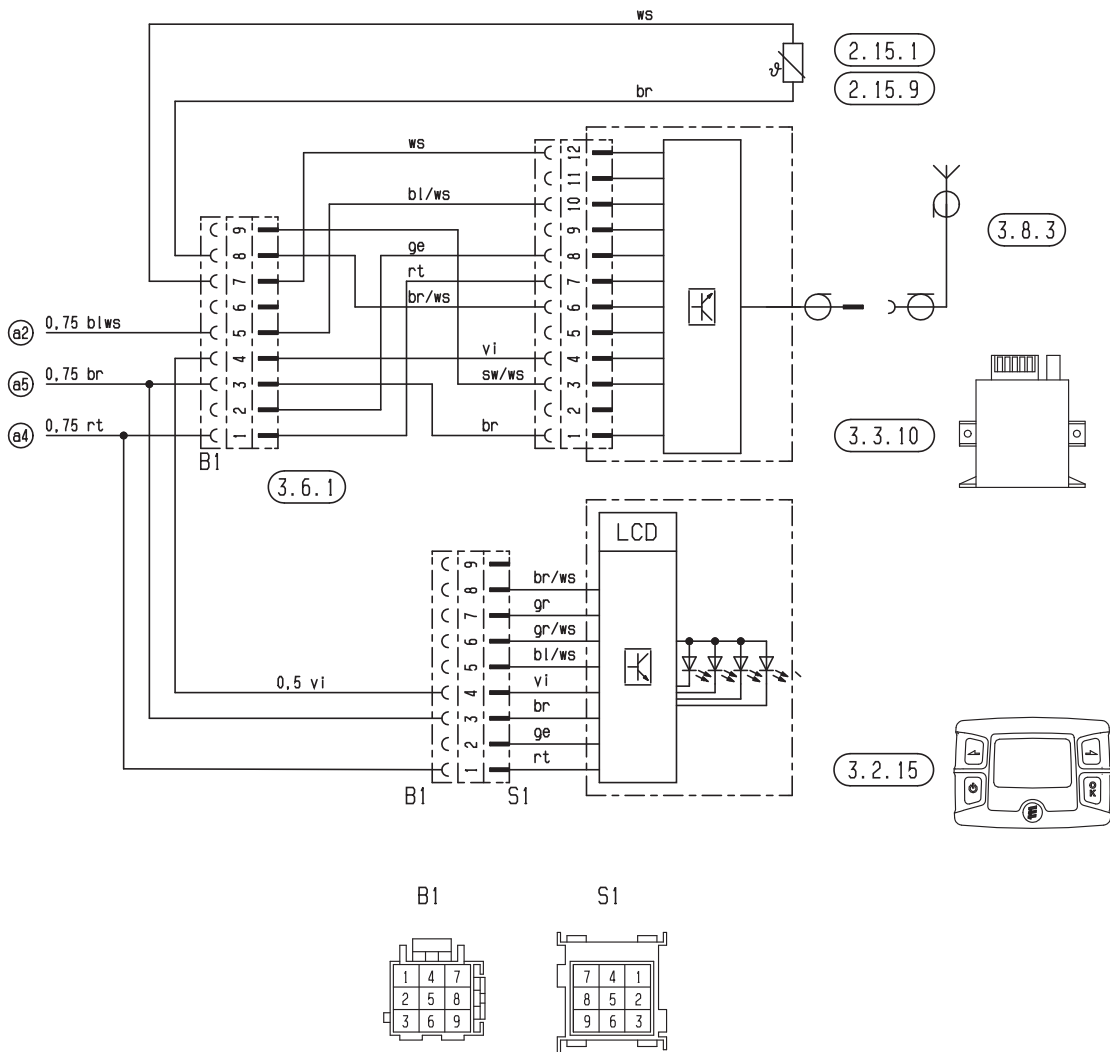
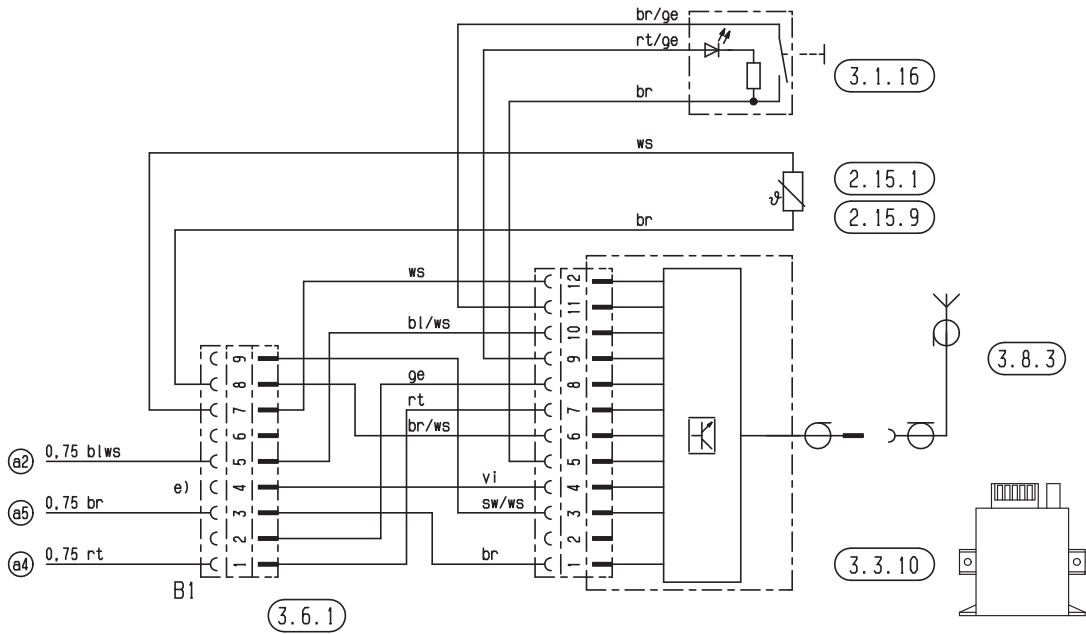

6 Circuit diagram

Circuit diagram for EasyStart R control unit

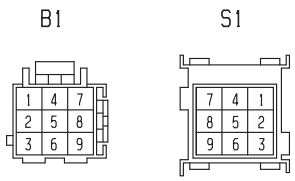
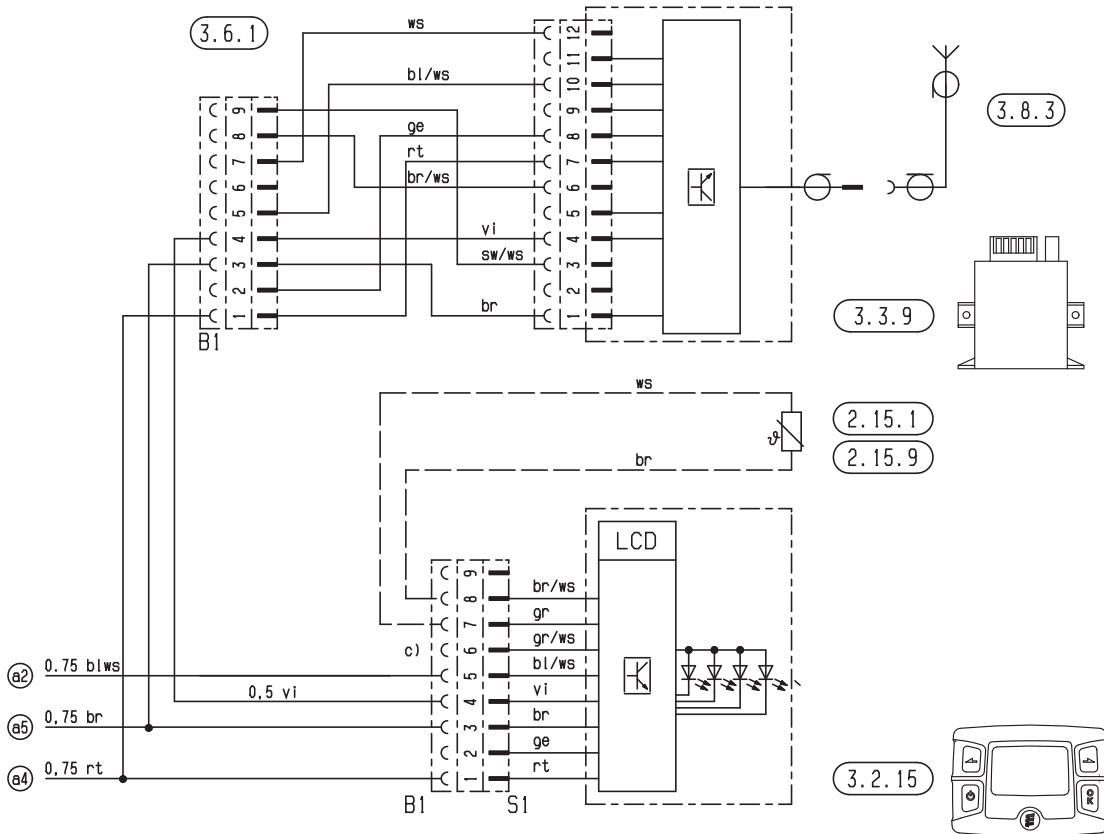
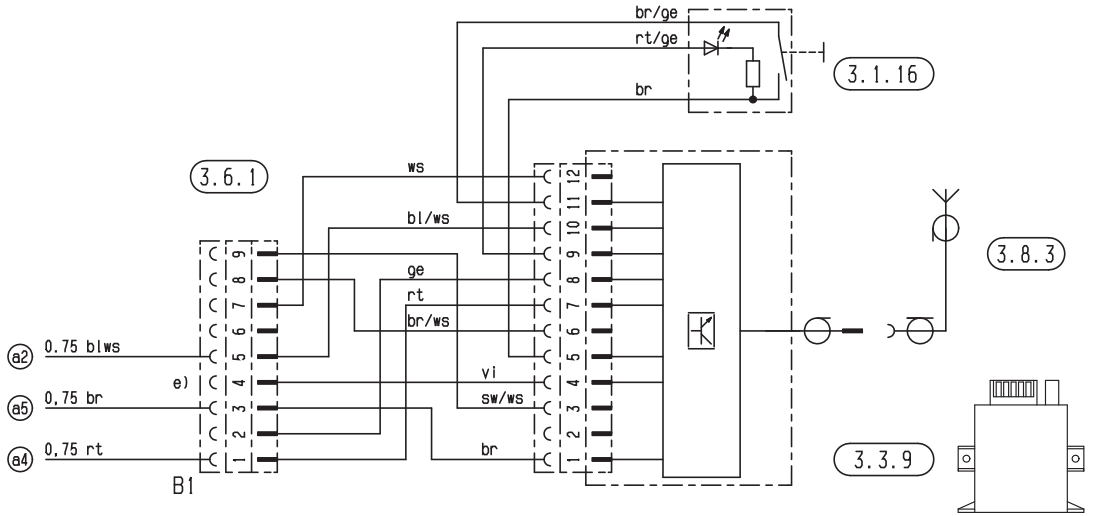



6 Circuit diagram

Circuit diagram for EasyStart T control unit

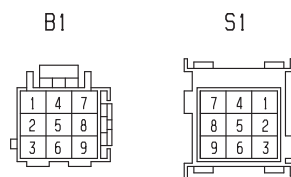
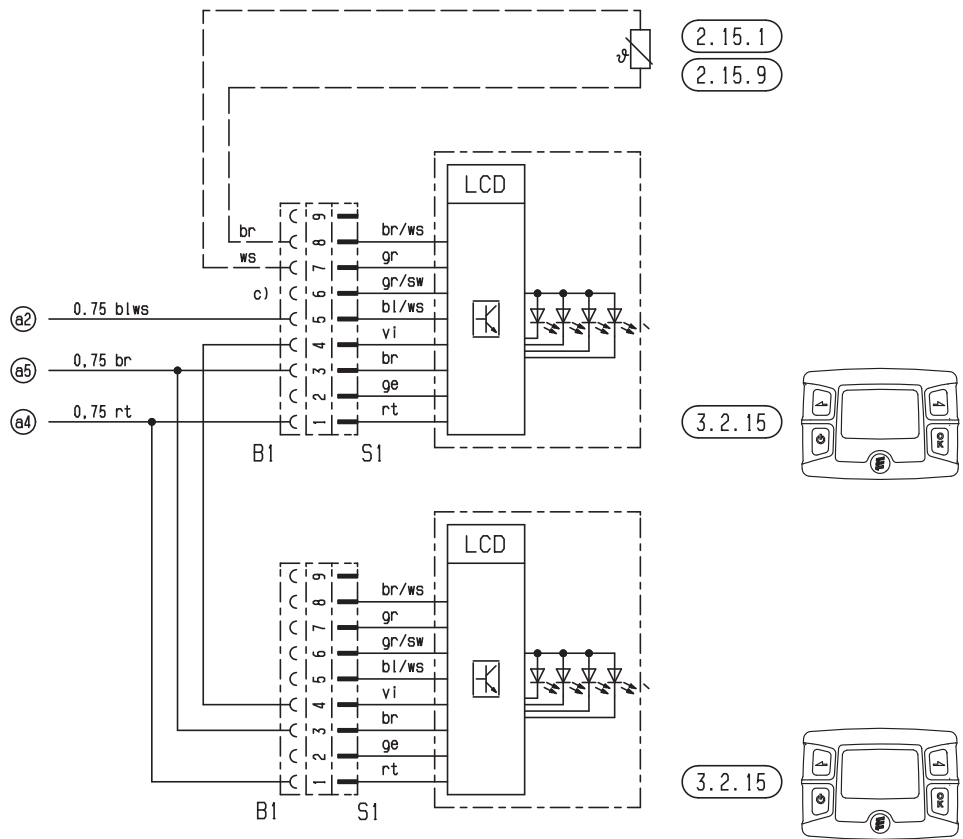
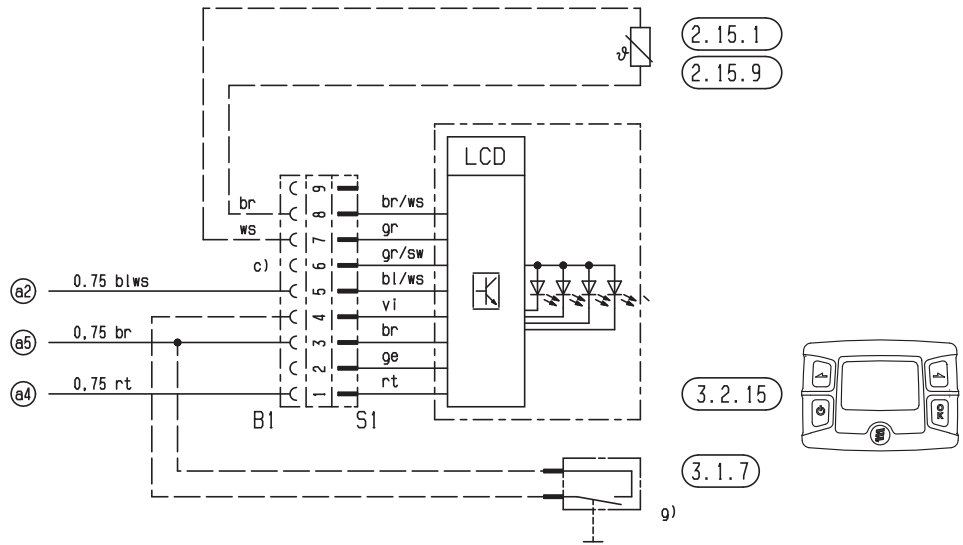

6 Circuit diagram

Circuit diagram for EasyStart T – ADR control unit

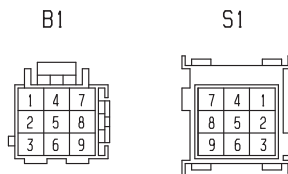
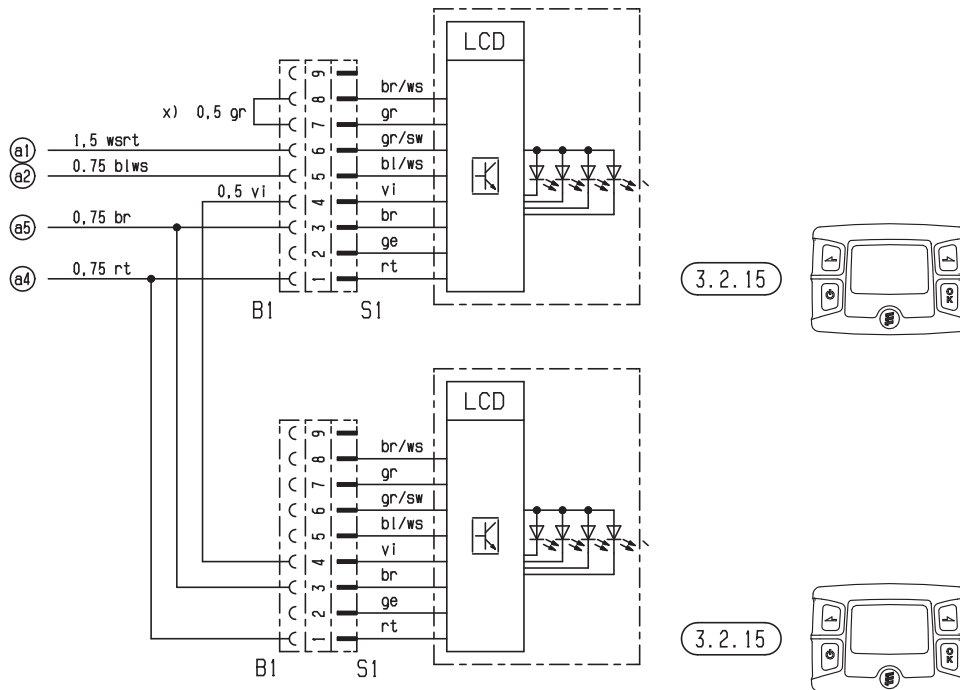
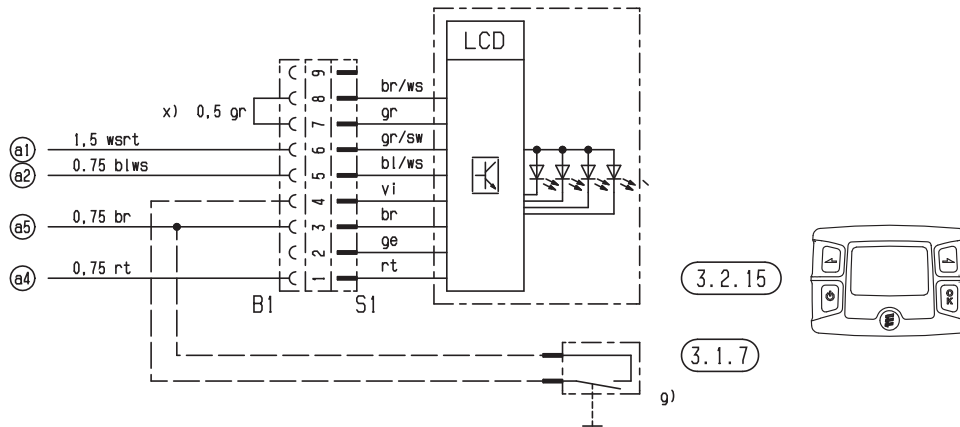



7 Service

Certifications

The high quality of Eberspächer products is the key to our success.

To guarantee this quality, we have organised all work processes in the company along the lines of quality management (QM). Even so, we still pursue a large number of activities for continuous improvement of product quality in order to keep pace with the similarly constantly growing requirements made by our customers.

All the steps necessary for quality assurance are stipulated in international standards.

This quality is to be considered in a total sense.

It affects products, procedures and customer / supplier relationships.

Officially approved public experts assess the system and the corresponding certification company awards a certificate.

Eberspächer has already qualified for the following standards:

**Quality management in accordance with
DIN EN ISO 9001:2000 and ISO/TS 16949:1999**

**Environmental management system in accordance with
DIN EN ISO 14001:1996**

Disposal

Disposal of materials

Old devices, defect components and packaging material can all be separated and sorted into pure-grade factions so that all parts can be disposed of as required in an environment-friendly manner recycled where applicable.

Electric motors, control boxes and sensors (e.g. temperature sensors) are deemed to be "electronic scrap".

Dismantling the heater

The heater is dismantled according to the repair stages in the current troubleshooting / repair instructions.

Packaging

The packaging of the heater can be kept in case it has to be sent back.

EC Declaration of Conformity

With regard to the following products

Heater type Hydronic M-II

we herewith confirm that it conforms with the prime safety requirements stipulated in the directives of the EU Council for harmonisation of the legal regulations of the member states with regard to electromagnetic compatibility (89 / 336 / EEC). This declaration applies to all heaters produced according to the production drawings Hydronic M-II – which are an integral part of this declaration.

The following standards / directives have been used to assess the product with regard to electromagnetic compatibility:

- EN 50081 – 1 Generic emission standard.
- EN 50082 – 1 Generic immunity standard.
- 72 / 245 / EEC – Modification status 2006 / 28 / EC Interference suppression in motor vehicles.

8 Lists

List of keywords A – Z

Keyword	Page
A	
Accident prevention.....	4
Adapter cable.....	13, 14, 16
ADR / ADR99.....	7
AMP release tool.....	21
Assembly drawing.....	22
C	
Cancel the control box lock.....	13, 15, 16, 17
Certification.....	51
Check flame sensor.....	38
Check overheating sensor.....	37
Check temperature sensor.....	37
Circuit diagrams.....	42, 44, 47 – 50
Combustion air blower unit.....	23 – 34
Combustion chamber.....	22, 23, 27 – 29
Contents.....	2, 3
Control and safety devices.....	7
Control box / blower unit.....	24 – 34
Cutaway view.....	5
D	
Declaration of conformity.....	51
Delivery curve of water pump.....	11
Description of functions.....	6
Diagnostic unit.....	13, 14
Diesel – commercially available.....	8 – 10
Disposal.....	51
E	
EasyStart R+ radio remote control.....	13, 17
EC Declaration of Conformity.....	51
EDiTH diagnostics tool.....	13, 16
Electrical power consumption.....	8 – 10
EMC directive.....	55
Emergency off.....	7
Emergency shutdown.....	7
Environment.....	51
F	
FAME.....	8, 55
Fault code display.....	18 – 20
Fault description.....	18 – 20
Fault diagnosis.....	13 – 17
Flame sensor.....	23, 26, 27, 30
Forced shutdown.....	7
Foreword.....	4
Fuel.....	8 – 10
Function.....	5 – 7
G	
Glow plug.....	23, 26, 27, 29, 31
H	
Heat exchanger.....	23
Heating mode.....	6

Keyword	Page
I	
Ignition air drillhole.....	35
Individual parts list.....	23
Introduction.....	2 – 4
L	
List of abbreviations.....	55
Lists.....	54, 55
M	
Measure fuel quantity.....	40
Minimum water flow rate.....	8 – 10
O	
Overheating sensor.....	23, 24, 33, 37
P	
Parts list circuit diagram.....	43, 45, 46
Picture symbols.....	4
Power consumption.....	8 – 10
Product information.....	8 – 11
Q	
Quality management.....	51
Quality.....	51
R	
Rated voltage.....	8 – 10
Remedial action.....	18 – 20
Remove / install glow plug.....	35
Repair instructions.....	21 – 40
Representatives abroad.....	52, 53
Rewiring cable harness connector.....	41
S	
Service.....	51 – 53
Switching on.....	6
T	
Technical data.....	8 – 11
Temperature sensor.....	23, 24, 33, 37
Testing equipment.....	13
Troubleshooting.....	12 – 20
W	
Water pump.....	23, 25, 33, 39
Wiring.....	41



List of abbreviations

ADR

European agreement about the international transport of dangerous goods on the road.

ADR99

Dangerous goods regulations for France.

EC type-approval

Permit awarded by the Federal Vehicle Office for the production of a heater for installation in motorised vehicles.

EMC directive

Electromagnetic compatibility.

JE-partner

J. Eberspächer partner.

FAME (biodiesel)

FAME for diesel engines according to DIN EN 14 214

