

TROUBLESHOOTING AND REPAIR INSTRUCTIONS

HYDRONIC II



THE TROUBLESHOOTING AND REPAIR INSTRUCTIONS ARE ONLY VALID FOR THE FOLLOWING ENGINE-INDEPENDENT WATER HEATERS

Heaters for petrol

B 4 S – 12 V 20 1909 05 00 00

B 5 S – 12 V 20 1904 05 00 00

Heaters for bioethanol fuel

E 4 S – 12 V 20 1920 05 00 00

Heaters for diesel

D 4 S – 12 V 25 2554 05 00 00

D 4 S – 12 V 25 2558 05 00 00 (with inlet pressure resistant metering pump)

D 5 S – 12 V 25 2526 05 00 00

D 5 S – 12 V 25 2557 05 00 00 (with inlet pressure resistant metering pump)

CONTENTS

CONTENTS

This list of contents gives you precise information about the contents of the Troubleshooting and Repair Instructions.

If you are looking for a term, technical term or you would like an abbreviation explained, please use the relevant index at the end of the instructions.

CHAPTER TITLE CONTENT PAGE

1	Introduction	Foreword	5
		Special text structure, presentation and picture symbols	5
		– Special text formats and presentations	5
		– Picture symbols	5
		Heater documentation	5
		– Content and purpose of these troubleshooting and repair instructions	5
		Further documentation	5
		– Technical description, installation, operating and maintenance instructions	5
		– Spare parts list	5
		Safety instructions for installation and repair	6
		Liability claim / Guarantee	6
		Accident prevention	6
		Initial start-up of the heater or functional test after a repair	6
		Emergency shutdown – EMERGENCY OFF	6
2	Function and operation	Cutaway view	7
		Functional description	8
		– Switching on – Parking heater mode	8
		– Heating mode	8
		– Heating at high altitudes	8
		Control and safety devices	8
		3	Technical data
Hydronic II B 5 S petrol heater	10		
Hydronic II D 4 S diesel heater	11		
Hydronic II D 5 S diesel heater	12		
Water pump	13		
– Water pump characteristic curve	13		
4	Troubleshooting	What to check first in case of faults	14
		Locking the control box	14
		– The control box is locked if the following faults occur:	14
		– Cancel the control box lock	14
		Overview of the test equipment and control units	15
		External diagnostics system	15

CONTENTS

	Fault diagnosis using the EDiTH Basic diagnostics tool	16
	– Connect EDiTH Basic	16
	– Start the diagnosis query.	17
	– Delete the fault memory and at the same time cancel the control box lock	17
	Fault diagnosis using the control unit	18
	– Diagnosis capable control unit	18
	Query / delete fault memory and cancel the heater lock	18
5	Repair instructions	
	Before working on the heater, always follow the relevant safety instructions	24
	Special tool	24
	– AMP release tool	24
	Assembly drawing	25
	Repair steps	26
	Connector assignment – 10-pin connector S1	26
	Dismantle the heater	27
	Repair step 1	27
	– Remove "control box" cover	27
	Repair step 2	27
	– Remove "blower" cover	27
	Repair step 3	28
	– Remove connecting sockets from the "control box" cover	28
	Repair step 4	29
	– Dismantling the control box	29
	Repair step 5	30
	– Remove overheating sensor and surface sensor	30
	– Check overheating sensor	30
	– Table of values	30
	– Check the surface sensor	31
	– Table of values	31
	Repair step 6	32
	– Remove the "electric motor" cover and "blower sub-assembly with combustion chamber"	32
	– Remove the "electric motor" cover and "blower sub-assembly with combustion chamber"	33
	Repair step 7	33
	– Measure blower speed	33
	Repair step 8	34
	– Remove flame sensor	34
	– Check flame sensor	34
	– Table of values	34
	Repair step 9	35
	– Check glow plug	35
	– Dismantle glow plug	35

CONTENTS

		Measuring the fuel quantity, without EDITH Basic	36
		– Preparing for the measurement	36
		– Measurement	36
		– Evaluation	36
		Measuring the fuel quantity, with EDITH Basic	36
		– Preparing for the measurement	36
		– Measurement / evaluation	36
6	Electrics / Circuit diagram	Safety instructions for wiring the heater!	37
		Parts list for heater circuit diagram	37
		Assignment of connector S1	37
		Cable colours	37
		Heater circuit diagram	38
		Circuit diagram control unit – EasyStart R+	39
		Circuit diagram control unit – EasyStart R	40
		Circuit diagram control unit – EasyStart T	41
		Circuit diagram for control unit – Calltronic II	42
		Circuit diagram for control unit – EasyStart Call	43
7	Service	Certifications	44
		Disposal	44
		– Disposal of materials	44
		– Dismantling the heater	44
		– Packaging	44
		EC Declaration of Conformity	44
		List of key words	45
		List of abbreviations	47

1 INTRODUCTION

FOREWORD

These Troubleshooting and Repair Instructions are applicable to the heaters listed on the title page, to the exclusion of all liability claims. Depending on the version or revised status of the heater, there may be differences between it and these troubleshooting and repair instructions. The user must check this before carrying out the repair work and, if necessary, take the differences into account.

SPECIAL TEXT STRUCTURE, PRESENTATION AND PICTURE SYMBOLS

Special text formats and picture symbols are used in these instructions to emphasise different situations and subjects. Please refer to the following examples for their meanings and appropriate action.

SPECIAL TEXT FORMATS AND PRESENTATIONS

- This dot (▪) indicates a list, which is started by a heading.
 - If an indented dash (–) follows a "dot", this list is a sub-section of the black dot.

Underlined blue text denotes a cross-reference, which can be clicked in the PDF format. The part of the document named in the text is then displayed.

PICTURE SYMBOLS



This information points out a potential serious or fatal danger. Ignoring this information can result in severe injuries.

- ➔ This arrow indicates the appropriate precaution to take to avert the danger.



This information points out a dangerous situation for a person and / or the product. Failure to comply with these instructions can result in injuries to people and / or damage to machinery.

- ➔ This arrow indicates the appropriate precaution to take to avert the danger.



These remarks contain recommendations for use and useful tips for the operation, installation and repair of the heater.

HEATER DOCUMENTATION

CONTENT AND PURPOSE OF THESE TROUBLESHOOTING AND REPAIR INSTRUCTIONS

These instructions are to be used to correct faults and to perform repairs on the heater. The work required for this may only be done by personnel appropriately trained by a JE service partner.

FURTHER DOCUMENTATION

TECHNICAL DESCRIPTION, INSTALLATION, OPERATING AND MAINTENANCE INSTRUCTIONS

This documentation provides the JE service partner with all the necessary technical information, describes the correct installation in accordance with the regulations and provides the customer with the necessary information for safe operation of the heater.

SPARE PARTS LIST

The spare parts list provides the JE service partner with the necessary information for ordering spare parts in case of repairs.

1 INTRODUCTION

SAFETY INSTRUCTIONS FOR INSTALLATION AND REPAIR



CAUTION!

Improper installation or repair of Eberspächer heaters can cause a fire or result toxic exhaust entering the inside of the vehicle.

This can cause serious and even fatal risks.

- The heater may only be installed according to the specifications in the technical documents or repaired using original spare parts by authorised and trained persons.
- Installation and repairs by unauthorised and untrained persons, repairs using non-original spare parts and without the technical documents required for installation and repair are dangerous and therefore are not permitted.
- A repair may only be carried out in connection with the respective unit-related technical description, installation instructions, operating instructions and maintenance instructions.
This document must be carefully read through before / during installation and repair and followed throughout. Particular attention is to be paid to the official regulations, the safety instructions and the general information.

PLEASE NOTE!

- The relevant rules of sound engineering practice and any information provided by the vehicle manufacturer are to be observed during the installation and repair.
- When carrying out electric welding on the vehicle, the positive cable at the battery should be disconnected and placed at ground to protect the control box.

LIABILITY CLAIM / GUARANTEE

Eberspächer does not accept any liability for defects and damage, which are due to installation or repair by unauthorised and untrained persons.

Compliance with the official regulations and the safety instructions is prerequisite for liability claims.

Failure to comply with the official regulations and safety instructions leads to exclusion of any liability of the heater manufacturer.

ACCIDENT PREVENTION

General accident prevention regulations and the corresponding workshop and operating safety instructions are to be observed.

INITIAL START-UP OF THE HEATER OR FUNCTIONAL TEST AFTER A REPAIR

- After installation or carrying out a repair on the heater, the coolant circuit and the whole fuel supply system must be vented carefully.
- Comply with the instructions issued by the vehicle manufacturer.
- Open all heating circuits before the trial run (set the temperature control to "warm").
- During the heater trial run, all water and fuel connections must be checked for leaks and secure, tight fit.
- If faults occur while the heater is running, use a diagnostic unit to correct the cause of the fault.

EMERGENCY SHUTDOWN – EMERGENCY OFF

If an emergency shutdown – EMERGENCY OFF – is necessary during operation, proceed as follows:

- Switch the heater off at the control element or
- remove the fuse or
- disconnect the heater from the battery.

2 FUNCTION AND OPERATION

CUTAWAY VIEW

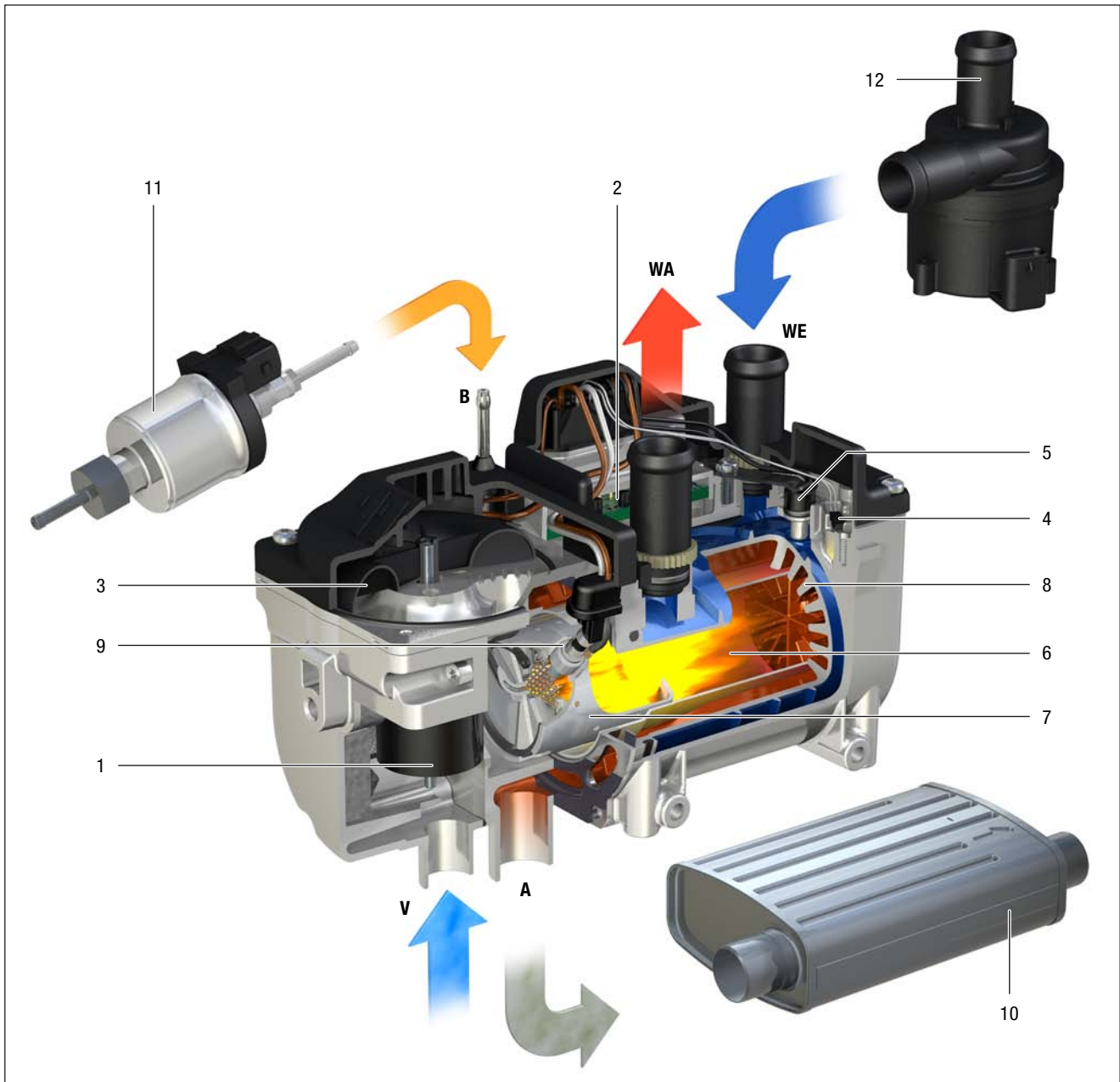

- 1 Electrical motor
- 2 Control box
- 3 Combustion air fan
- 4 Surface sensor
- 5 Overheating sensor
- 6 Flame sensor
- 7 Combustion chamber
- 8 Heat exchanger
- 9 Glow plug

- 10 Exhaust silencer
- 11 Metering pump
- 12 Water pump

- A = Exhaust
- B = Fuel
- V = Combustion air
- WA = Water outlet
- WE = Water inlet

2 FUNCTION AND OPERATION

FUNCTIONAL DESCRIPTION

SWITCHING ON – PARKING HEATER MODE

When the heater is switched on, the  symbol appears in the control unit.

HEATING MODE

The water pump starts up and, following a preset sequence, the combustion air fan, glow plug and metering pump are started.

The glow plug is switched off once a stable flame has formed in the combustion chamber.

Depending on the heat requirements, the heater runs at the following levels:

Power – High – Low – Off (pause mode). The temperature thresholds for these are permanently programmed in the electronic control box.

The heater starts in "Power" control stage.

After the cooling water temperature has reached approx. 65 °C – depending on the selected blower setting – the heater switches to the "High" control stage.

If the cooling water continues to rise up to 80 °C, the heater switches to "Low" control stage.

- If the heat output achieved in "Low" control stage is insufficient, the cooling water temperature drops to 75 °C – the heater switches back to "High" control stage.
- If the heating output in "low" control stage is inadequate, the cooling water temperature rises to 85 °C. The heater switches to "off" control stage (pause mode) and an after-run follows,
 - 120 seconds for petrol / ethanol heaters,
 - 90 seconds for diesel heaters.
- If the cooling water temperature cools to 75 °C during pause mode, a controlled start occurs in a high control stage.

During pause mode the water pump continues to run and the  symbol continues to be displayed in the control unit.

HEATING AT HIGH ALTITUDES

When using the heater at high altitudes, please note:

- Heating at altitudes up to 1500 m asl:

Petrol, diesel and ethanol heaters:

 - Unlimited heating possible.
- Heating at altitudes over 1500 m - 3000 m asl:

Petrol and diesel heaters:

 - The heater can be run for short periods (e.g. driving through a mountain pass or taking a break in your journey).
 - During longer stays, e.g. winter camping, the fuel supply must be adjusted to the altitude. This can be done by installing an air pressure sensor. The air pressure sensor is included in the altitude kit
 - Order No. 22 1000 33 22 00.

Ethanol heaters:

 - Consult the manufacturer.

CONTROL AND SAFETY DEVICES

- If, 100 seconds after being switched on for petrol heaters and 70 seconds after being switched on for diesel heaters, the heater does not ignite, the start is repeated.

The heater is automatically shut down if, after three further start attempts in the case of a petrol / ethanol heaters and two attempts with a diesel heater, the heater fails to start within the preset safety period (240 seconds).

After an impermissible number of failed start attempts, the control box is locked.*
- If the flame independently goes out during operation, the heater is restarted and if necessary, a maximum of two further start attempts are made within the preset safety time.

If the heater does not ignite or ignites but goes out again within 15 minutes, a safety lock-out occurs.

The safety lock-out can be cancelled by briefly switching off and on again (heater ON / OFF).
- In the case of overheating (e.g. lack of water, poorly ventilated cooling water circuit), the overheating sensor triggers, the fuel feed is interrupted and the heater is automatically switched off. Once the cause of the overheating has been eliminated, the heater can be restarted by switching off and on again (heater ON / OFF).

Requirement: the heater is sufficiently cooled, cooling water temperature < 70 °C. After an impermissible number of shut-downs on overheating the control box is locked*.
- If the lower or upper voltage limit is reached, the heater is automatically shut down.
- The heater does not start up if the glow plug is defective.
- The blower motor is monitored. If the blower motor does not start up or if it is blocked, the heater is automatically switched off after 60 sec.
- If the line to the metering pump is interrupted, the whole of the start program is still run through; the heater is then switched off.

* Cancellation of the lock or reading out errors is possible

- using the EasyStart T timer,
- using the EasyStart R+ radio remote control.
- using the EDiTH diagnostics tool.

For operation and fault list, please refer to the enclosed operating instructions or the troubleshooting and repair instructions for the heater.

PLEASE NOTE!

Do not repeat the switching off / on routine more than twice.

3 TECHNICAL DATA

HYDRONIC II B 4 S / E 4 S PETROL / BIOETHANOL HEATER

Heater type	Hydronic II					
	B 4 S			E 4 S		
Heater version	B 4 S			E 4 S		
Heating medium	Mixture of water and coolant (max. 50 % coolant)					
Fuel	Petrol – standard commercially available (DIN 51600 and EN 228)			Bio-ethanol fuel – E85 to DIN 51625 and E100		
Rated voltage	12 volt					
Control of the heat flow	Power	High	Low	Power	High	Low
Heat flow (watt)	4400	4000	2300	4300	3700	1300
Fuel consumption (l/h)	0.62	0.55	0.32	0.78	0.67	0.23
Average electrical power consumption (watt) without water pump	during operation					
	27	21	12	27	20	7
Operating range	while starting					
	120					
Lower voltage limit: An undervoltage protection installed in the control box switches off the heater if the lower voltage limit is reached.	10.5 volt					
Upper voltage limit: An overvoltage protection installed in the control box switches off the heater if the upper voltage limit is reached.	16 volt					
Allowable operating pressure	up to 2.5 bar overpressure max.					
Water volume in the heater	approx. 0.18 l					
Minimum water flow rate of the heater	250 l/h					
Allowable ambient temperature	During operation			Without operation		
	Heater, continuous	-40 °C to +60 °C		-40 °C to +105 °C		
	Heater, short time	---		+125 °C (5 x 2 h)		
Coolant water temperature	continuous			-40 °C to +120 °C		
	short time			-40 °C to +120 °C		
Interference suppression class	5 (EN 55025)					
Weight – without coolant and attachments	approx. 2.4 kg					



CAUTION!

Operating the heater outside the specified technical data can cause malfunctions.

➔ The technical data must be complied with at all times.



PLEASE NOTE!

If no limit values are given, the technical data listed is with the usual heater tolerances of $\pm 10\%$ at nominal voltage and Esslingen reference altitude.

3 TECHNICAL DATA

HYDRONIC II B 5 S PETROL HEATER

Heater type	Hydronic II		
Heater version	B 5 S		
Heating medium	Mixture of water and coolant (max. 50 % coolant)		
Fuel	Petrol – standard commercially available (DIN 51600 and EN 228) E85 ethanol fuel (DIN 51625)		
Rated voltage	12 volt		
Control of the heat flow	Power	High	Low
Heat flow (watt)	5200	5000	2300
Fuel consumption (l/h)	0.72	0.69	0.32
Average electrical power consumption (watt) without water pump			
during operation	40	37	12
while starting	120		
Operating range			
Lower voltage limit: An undervoltage protection installed in the control box switches off the heater if the lower voltage limit is reached.	10.5 volt		
Upper voltage limit: An overvoltage protection installed in the control box switches off the heater if the upper voltage limit is reached.	16 volt		
Allowable operating pressure	up to 2.5 bar overpressure max.		
Water volume in the heater	approx. 0.18 l		
Minimum water flow rate of the heater	250 l/h		
Allowable ambient temperature	During operation		Without operation
Heater, continuous	–40 °C to +60 °C		–40 °C to +105 °C
Heater, short time	---		+125 °C (5 x 2 h)
Coolant water temperature	continuous		short time
continuous	–40 °C to +120 °C		–40 °C to +120 °C
short time	---		+125 °C (1 h)
Interference suppression class	5 (EN 55025)		
Weight – without coolant and attachments	approx. 2.4 kg		

CAUTION!

Operating the heater outside the specified technical data can cause malfunctions.

➔ The technical data must be complied with at all times.

PLEASE NOTE!

If no limit values are given, the technical data listed is with the usual heater tolerances of $\pm 10\%$ at nominal voltage and Esslingen reference altitude.

3 TECHNICAL DATA

HYDRONIC II D 4 S DIESEL HEATER

Heater type	Hydronic II		
Heater version	D 4 S		
Heating medium	Mixture of water and coolant (max. 50 % coolant)		
Fuel	Diesel – standard commercially available (EN 590) Blending with max. 20 % FAME according to EN 14214 is permitted		
Rated voltage	12 volt		
Control of the heat flow	Power	High	Low
Heat flow (watt)	4300	4100	2100
Fuel consumption (l/h)	0.52	0.50	0.26
Average electrical power consumption (watt) without water pump			
during operation	27	21	12
while starting	120		
Operating range			
Lower voltage limit: An undervoltage protection installed in the control box switches off the heater if the lower voltage limit is reached.	10.5 volt		
Upper voltage limit: An overvoltage protection installed in the control box switches off the heater if the upper voltage limit is reached.	16 volt		
Allowable operating pressure	up to 2.5 bar overpressure max.		
Water volume in the heater	approx. 0.18 l		
Minimum water flow rate of the heater	250 l/h		
Allowable ambient temperature	During operation		Without operation
Heater, continuous	-40 °C to +80 °C		-40 °C to +105 °C
Heater, short time	---		+125 °C (5 x 2 h)
Coolant water temperature	continuous		short time
continuous	-40 °C to +120 °C		-40 °C to +120 °C
short time	---		+125 °C (1 h)
Interference suppression class	5 (EN 55025)		
Weight – without coolant and attachments	approx. 2.4 kg		

CAUTION!

Operating the heater outside the specified technical data can cause malfunctions.

➔ The technical data must be complied with at all times.

PLEASE NOTE!

If no limit values are given, the technical data listed is with the usual heater tolerances of $\pm 10\%$ at nominal voltage and Esslingen reference altitude.

3 TECHNICAL DATA

HYDRONIC II D 5 S DIESEL HEATER

Heater type	Hydronic II		
Heater version	D 5 S		
Heating medium	Mixture of water and coolant (max. 50 % coolant)		
Fuel	Diesel – standard commercially available (EN 590) Blending with max. 20 % FAME according to EN 14214 is permitted		
Rated voltage	12 volt		
Control of the heat flow	Power	High	Low
Heat flow (watt)	5200	5000	2100
Fuel consumption (l/h)	0.64	0.61	0.26
Average electrical power consumption (watt) without water pump			
during operation	40	37	12
while starting	120		
Operating range			
Lower voltage limit: An undervoltage protection installed in the control box switches off the heater if the lower voltage limit is reached.	10.5 volt		
Upper voltage limit: An overvoltage protection installed in the control box switches off the heater if the upper voltage limit is reached.	16 volt		
Allowable operating pressure	up to 2.5 bar overpressure max.		
Water volume in the heater	approx. 0.18 l		
Minimum water flow rate of the heater	250 l/h		
Allowable ambient temperature	During operation		Without operation
Heater, continuous	–40 °C to +80 °C		–40 °C to +105 °C
Heater, short time	---		+125 °C (5 x 2 h)
Coolant water temperature	continuous		short time
continuous	–40 °C to +120 °C		–40 °C to +120 °C
short time	---		+125 °C (1 h)
Interference suppression class	5 (EN 55025)		
Weight – without coolant and attachments	approx. 2.4 kg		

CAUTION!

Operating the heater outside the specified technical data can cause malfunctions.

➔ The technical data must be complied with at all times.

PLEASE NOTE!

If no limit values are given, the technical data listed is with the usual heater tolerances of $\pm 10\%$ at nominal voltage and Esslingen reference altitude.

3 TECHNICAL DATA

WATER PUMP

Rated voltage	12 volt
Operating voltage	9 volt to 16 volt
Electrical power consumption	< 12 watt
Delivery rate	680 l/h
Delivery pressure difference	0.1 bar
Operating temperature	-40 °C to +125 °C

WATER PUMP CHARACTERISTIC CURVE

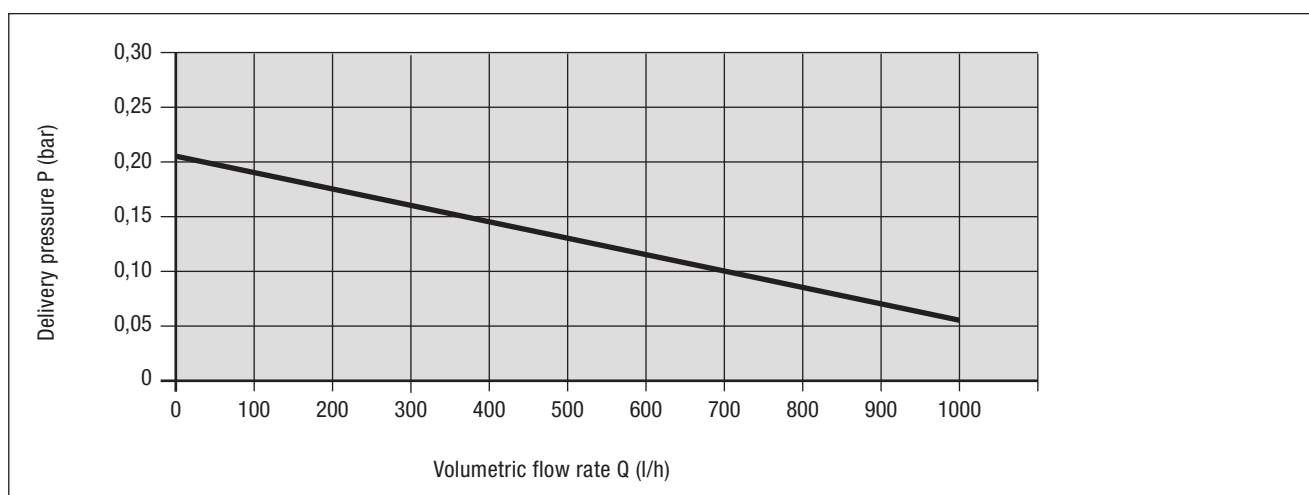

CAUTION!

Operating the water pump outside the specified technical data can cause malfunctions.

→ The technical data must be complied with at all times.

PLEASE NOTE!

If no limit values are given, the technical data listed is with the usual heater tolerances of $\pm 10\%$ at nominal voltage and Esslingen reference altitude.

4 TROUBLESHOOTING

WHAT TO CHECK FIRST IN CASE OF FAULTS

- **Check**
 - Fuel in the tank?
 - Fuel pipes leaking? (visual check)
 - In the case of diesel heaters, summer diesel still in the fuel lines?
 - Heating control (water valve) fully set to "WARM"?
 - Combustion air system or exhaust system damaged or blocked?
- **Electrical components**
 - Cables, connections damaged?
 - Contacts corroded?
 - Fuses defective?
 - Incorrect wiring? (short circuit, interruption)
- **Check battery voltage**
 - Battery voltage < 10 volt, the undervoltage protection has triggered.
 - Battery voltage > 16 volt, the overvoltage protection has triggered.
- **Check voltage supply U_{Batt} (Terminal 30)**

Disconnect the 10-pin connector S1 / B1 and measure the applied voltage in connector B1 between chamber 1 (cable 2.5² rt) and chamber 2 (cable 2.5² br).

If it differs from the battery voltage, check the fuses, the supply cables, the ground connection and the positive support point on the battery for voltage drop (corrosion / interruption).

LOCKING THE CONTROL BOX

THE CONTROL BOX IS LOCKED IF THE FOLLOWING FAULTS OCCUR:

- **Too many attempted starts**

If the heater carries out several consecutive unsuccessful started attempts [Fault code 050](#) is displayed – the control box is locked.
- **Overheating**

If the heater overheats several times in succession [Fault code 015](#) is displayed – the control box is locked.

CANCEL THE CONTROL BOX LOCK

Cancellation of the control box lock depends on the appropriate test equipment and is described [from page 17](#).

4 TROUBLESHOOTING

OVERVIEW OF THE TEST EQUIPMENT AND CONTROL UNITS

The electronic control box can store up to 5 faults, which can be read out and displayed.

The following test equipment / control units can be used to query the fault memory in the control box and if necessary to delete the locking of the control box:

Testing equipment	Order no.
<ul style="list-style-type: none"> EDiTH Basic diagnosis tool can be used from software version S4V1-F. The software can be downloaded from the service portal. Also required: for EasyStart T / EasyStart R+	22 1541 89 00 00
Adapter cable	22 1000 33 78 00
for EasyStart Call	
Adapter cable	22 1000 34 11 00

Control unit	Order no.
<ul style="list-style-type: none"> EasyStart T 	22 1000 32 88 00
<ul style="list-style-type: none"> EasyStart R+ 	22 1000 32 80 00
<ul style="list-style-type: none"> EasyStart Call 	22 1000 34 01 00

PLEASE NOTE!

- The diagnostics cable (cable 0.5² bl/ws) must also be connected if using control units.
If the fault memory cannot be read out, check the diagnostics cable is properly laid and is not damaged.

EXTERNAL DIAGNOSTICS SYSTEM

If an external, vehicle-specific diagnostics system is used ⇒ please consult the vehicle manufacturer.

4 TROUBLESHOOTING

FAULT DIAGNOSIS USING THE EDITH BASIC DIAGNOSTICS TOOL

PLEASE NOTE!

- Always connect in the given order!
- The plug-in "diagnosis" connection may not be disconnected until the heater has been switched off and the after-running has finished!
- Check whether version S3V10-F of the EDiTH software required for the diagnosis has been installed on the PC, if necessary the version can be downloaded from the service portal.
- Follow the operating instructions for the EDiTH Basic (ISO adapter) diagnostics tool.
- When the plug-in "diagnosis" connection (A) is disconnected the voltage supply for the control unit is retained.
- Fault code, fault description, cause / remedial action are described [from page 19](#).

CONNECT EDITH BASIC

1. Disconnect the plug-in "diagnosis" connection (A) in the heater cable harness.
2. Connect 3-pin connector housing (1) of the adapter cable (B) to the plug-in "diagnosis" connection (A).
3. Connect the 6-pin receptacle housing (2) of the adapter cable (B) with the 6-pin tab connector housing (3) of the EDiTH Basic (C) diagnosis tool.
4. Connect the SUB-D connection cable (E) to the EDiTH Basic diagnosis tool (C) and to the PC (D).

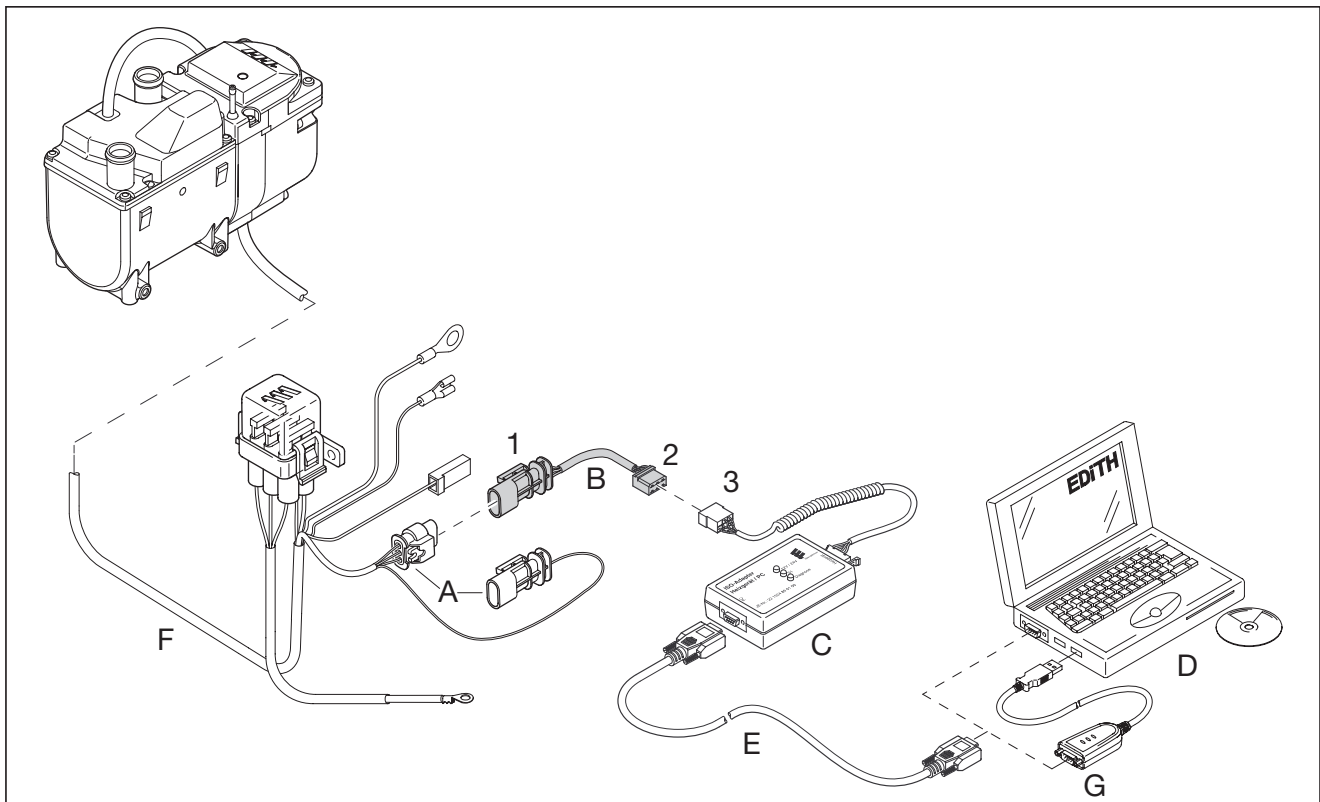

A Plug-in "diagnosis" connection

B Adapter cable

C EDiTH Basic diagnosis tool

D PC

E Sub-D connection cable

F Heater cable harness

G USB adapter

1 3 pin connector housing of adapter cable

2 6 pin receptacle housing of adapter cable

3 6-pin tab connector housing of EDiTH Basic diagnosis tool

4 TROUBLESHOOTING

START THE DIAGNOSIS QUERY.

- Double-click the «EDiTH» icon on the Desktop to start the diagnostic software ⇒ The EDiTH Start window opens.
- Double-click the «flame» button ⇒ «Heaters and test selection» window opens.
 - Select the heater by its «Version No.» or via the «Automatic search».
- In the «Test» window, double-click «General Data +Fault Memory» to open the «Fault memory» window.
 - The fault code of the current fault/error is and the fault code of faults/errors F1 – F5 are displayed.

DELETE THE FAULT MEMORY AND AT THE SAME TIME CANCEL THE CONTROL BOX LOCK

- In the "Fault memory" window, press the "Delete fault memory" button in the menu bar.
 - The whole fault memory is deleted and the control box is unlocked.

4 TROUBLESHOOTING

FAULT DIAGNOSIS USING THE CONTROL UNIT

DIAGNOSIS CAPABLE CONTROL UNIT

- EasyStart R+ radio remote control (Order No.: 22 1000 32 80 00)
- EasyStart T timer (Order No.: 22 1000 32 88 00)

If faults occur in the heater while it is running, they are displayed with "Err" after the mobile unit or timer has been activated.

The current fault and the stored faults "F1" to "F5" can be queried.

PLEASE NOTE!

- The bl/ws diagnostics cable must be connected in order to perform the diagnosis. To this end, please refer to and follow the circuit diagram for the radio remote control or the timer and for the heater.
- If the diagnostics cable is not connected, the "Diagnosis" menu is blocked.
- Not only the defective component, but also a defective current circuit results in a fault being displayed.
- Fault code, fault description, cause / remedial action are described [from page 19](#).
- Ensure sufficient battery voltage (min. 10.5 volt).



- Back control button
- Next control button
- ON / OFF activation button for mobile unit / timer
- OK button (symbol selection / input confirmation)

QUERY / DELETE FAULT MEMORY AND CANCEL THE HEATER LOCK

Activate mobile unit / timer

(see EasyStart R+ / EasyStart T operating instructions)

Confirm symbol with .

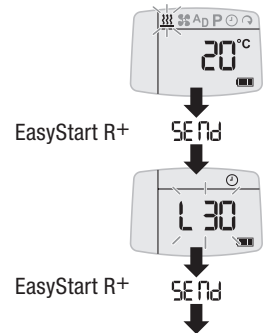

Heater is switched on.

Confirm operating time with .

Following activation, the following can be shown in the display (display appears after approx. 20 sec.):

Display if errors/faults exist



Display if no errors/faults exist



The following actions are possible with both displays:

- Display current fault in fault memory.

and at the same time briefly press .



- Display fault memory F1 – F5

or press .



The current fault is always written in fault memory F1.

- Display current fault in the fault memory again.

and, at the same time, briefly press .



- Delete the fault memory and as a result, at the same time cancel the control box lock

Confirm current fault or one of the faults F1 – F5 with .



Confirm dEL display again with .

The fault memory is deleted and the control box is unlocked.

- Switch off the heater.



press.







4 TROUBLESHOOTING

FAULT CODE DISPLAY	FAULT DESCRIPTION	COMMENTS ▪ REMEDIAL ACTION
000	No faults	— —
009	Implausible air pressure information	Communication loss between the control box and air pressure sensor. <ul style="list-style-type: none"> ▪ Read out air pressure sensor fault memory (only using EDiTH Basic diagnosis tool, from software S3V7-F). ▪ Check wiring and plug-in connections, if ok replace ⇒ air pressure sensor.
010	Shutdown due to overvoltage (heater not functioning)	Overvoltage applied to control box for at least 20 seconds without interruption <ul style="list-style-type: none"> ▪ Disconnect plug-in connection B1/S1, vehicle engine on, measure voltage in connector B1 – between chamber 1, cable 2.5² rt and chamber 2, cable 2.5² br. Voltage >15 volt ⇒ check the generator regulator, check battery.
011	Shutdown due to undervoltage (heater not functioning)	Undervoltage applied to control box for at least 20 seconds without interruption <ul style="list-style-type: none"> ▪ Vehicle engine off, disconnect plug-in connection B1/S1, measure voltage in connector B1 – between chamber 1, cable 2.5² rt and chamber 2, cable 2.5² br. If the voltage is <10.5 volt ⇒, check the fuses, the supply cables, the ground connections and the positive support point at the battery for voltage drop (corrosion).
012	Overheating – software threshold exceeded	Temperature at overheating sensor >125 °C <ul style="list-style-type: none"> ▪ Check water circuit: <ul style="list-style-type: none"> – Heating control in max. position. – Check water circuit for leaks. – Vent water circuit. – If non-return valve / thermostat in the water circuit, check the flow direction. ▪ Check water throughput rate. ▪ Check overheating sensor: <ul style="list-style-type: none"> – Check cable for continuity, short circuit and damage. – Measure the resistive value in connector B2 – between chamber 10, cable 0.5² sw and chamber 11, cable 0.5² sw, see Page 30 for measured values. ▪ Check water pump, see Fault code 041 and 042.
013	Temperature difference error (before metering pump delivery)	Difference between the temperature values of the overheating sensor and the surface sensor is too large.
014	Possible overheating risk (1. differential evaluation) <p>PLEASE NOTE!</p> Fault code 014 is only displayed if the heater is running and the water temperature at the overheating sensor has reached at least 80 °C.	For remedial action see Fault code 012 . <ul style="list-style-type: none"> ▪ Check the surface sensor: <ul style="list-style-type: none"> – Check cable for continuity, short circuit and damage. – Measure the resistive value in connector B2 – between chamber 7, cable 0.5² ws and chamber 8, cable 0.5² ws, see Page 31 for measured values.
015	Operating lock-out – too many overheating events detected	The control box is locked due to consecutive too frequent overheating (Fault code 012 , 013 , 014 , 016). <ul style="list-style-type: none"> ▪ For remedial action see Fault code 012. ▪ Cancel the control box lock, see from page 14.

4 TROUBLESHOOTING

FAULT CODE DISPLAY	FAULT DESCRIPTION	COMMENTS ▪ REMEDIAL ACTION
016	Possible overheating risk (2. differential evaluation)  PLEASE NOTE! Fault code 016 is only displayed if the heater is running and the water temperature at the overheating sensor has reached at least 80 °C.	Difference between the temperature values of the overheating sensor and the surface sensor is too large. <ul style="list-style-type: none"> ▪ For remedial action see Fault code 012. ▪ Check the surface sensor: <ul style="list-style-type: none"> – Check cable for continuity, short circuit and damage. – Measure the resistance in connector B2 – between chamber 7, cable 0.5² ws and chamber 8, cable 0.5² ws – see Page 31 for measured values.
017	Overheating, hardware threshold exceeded	Temperature at overheating sensor >130 °C <ul style="list-style-type: none"> ▪ For remedial action see Fault code 012. ▪ Check the surface sensor: <ul style="list-style-type: none"> – Check cable for continuity, short circuit and damage. – Measure the resistance in connector B2 – between chamber 7, cable 0.5² ws and chamber 8, cable 0.5² ws – see Page 31 for measured values.
018 019	Glow plug – start energy too low Glow plug – ignition energy too low	Glow plug energy input is too low. <ul style="list-style-type: none"> ▪ Perform functional check on the glow plug, see Fault code 020.
020 021 022	Glow plug – interruption Glow plug – overload Glow plug – short circuit downstream of +Ub or transistor error  CAUTION! The glow plug is irreparably damaged if the voltage values are exceeded. → Perform the functional check with max. 9.5 volt.  PLEASE NOTE! Ensure the power pack has adequate short-circuit resistance.	Glow plug energy input is too low. <ul style="list-style-type: none"> ▪ Check cable for continuity, short circuit and damage. ▪ Perform functional check on the glow plug in installed condition. <ul style="list-style-type: none"> – Connector B2 – chamber 3, cable 1.5² br and chamber 6, cable 1.5² ws, unclip both cables. – Apply 9.5 V ±0.1 V voltage to the glow plug and after 25 sec measure the current intensity. – If 9.5 A (+1 A / –1.5 A) the glow plug is ok. – If values are different, renew the glow plug.
025	K-line – short circuit	Check the diagnostics cable: Connector B1 – chamber 5 and connector S8 – chamber 2, check cable 0.5 ² bl/ws for continuity, short circuit and damage, if ok ⇒ replace control box, see from Fault code 090 .

4 TROUBLESHOOTING

FAULT CODE DISPLAY	FAULT DESCRIPTION	COMMENTS ▪ REMEDIAL ACTION
030	<p>Speed of the burner motor is outside the allowable range</p> <p> CAUTION! The motor is irreparably damaged if the voltage values are exceeded. → Perform the functional check with max. 8.2 volt.</p> <hr/> <p> PLEASE NOTE!</p> <ul style="list-style-type: none"> ▪ Ensure correct connection of the plus (positive) and minus (negative) cables. ▪ Ensure the power pack has adequate short-circuit resistance. 	<p>Impeller blocked (frozen, soiled, sluggish, ...)</p> <ul style="list-style-type: none"> ▪ Remove blockage and manually turn the impeller to check the burner motor for smooth and easy running. ▪ Apply marking (white paint) to the impeller and measure the speed using a non-contact r.p.m. counter, see Page 33. <p>Unclip connector B2 – chamber 13, cable 0.75² sw and chamber 14, cable 0.75² br, perform the speed measurement with max. 8.2 volt (+ 0.2 volt).</p> <ul style="list-style-type: none"> – Speed <10000 rpm ⇒ renew the combustion air fan. – Speed > 10000 rpm ⇒ renew the control box.
031 032 035	<p>Burner motor – interruption Burner motor – short circuit Burner motor – short circuit downstream of +Ub or transistor error</p> <p> CAUTION! The motor is irreparably damaged if the voltage values are exceeded. → Perform the functional check with max. 8.2 volt.</p> <hr/> <p> PLEASE NOTE!</p> <ul style="list-style-type: none"> ▪ Ensure correct connection of the plus (positive) and minus (negative) cables. ▪ Ensure the power pack has adequate short-circuit resistance. 	<ul style="list-style-type: none"> ▪ Check burner motor cable: Check connector B2 – chamber 13, cable 0.75² sw and chamber 14, cable 0.75² br for continuity, short circuit and damage. ▪ Perform the speed measurement on the burner motor with max. 8.2 volt (+ 0.2 volt), see Fault code 030.
038 039	<p>Vehicle blower – interruption Vehicle blower – short circuit</p>	<ul style="list-style-type: none"> ▪ Check "blower" lead harness: Check connector B1 – chamber 3, cable 0.5² sw/rt and chamber 2, cable 2.5² br for continuity, short circuit and damage, if ok ⇒ replace relay (2.5.7.).
040	<p>Vehicle blower – short circuit downstream of +Ub or transistor error</p>	<ul style="list-style-type: none"> ▪ Pull off relay (2.5.7.), if fault code 038 is displayed, the relay (2.5.7.) is defective ⇒ renew relay (2.5.7.).
041 042	<p>Water pump – interruption Water pump – short circuit</p>	<ul style="list-style-type: none"> ▪ Check "water pump" lead harness: Check connector B1 – chamber 8, cable 0.75² vi and chamber 9, cable 0.75² br for continuity, short circuit and damage, if ok ⇒ replace water pump.
043	<p>Water pump – short circuit downstream of +Ub or transistor error</p>	<ul style="list-style-type: none"> ▪ Pull off connector at water pump, if fault code 041 is displayed, the water pump is defective ⇒ renew water pump.

4 TROUBLESHOOTING

FAULT CODE DISPLAY	FAULT DESCRIPTION	COMMENTS ▪ REMEDIAL ACTION
047 048	Metering pump – short circuit Metering pump interruption	<ul style="list-style-type: none"> ▪ Check "metering pump" lead harness: Check connector B1 – chamber 4, cable 0.75² gn and chamber 10, cable 0.75² br for continuity, short circuit and damage, if ok ⇒ replace metering pump.
049	Metering pump – short circuit downstream of of +Ub or transistor error	<ul style="list-style-type: none"> ▪ Disconnect connector connection of "metering pump" cable loom or unplug the plug at the metering pump, if Fault code 048 is displayed the metering pump is defective ⇒ renew the metering pump.
050	Operating lock-out - too many safety time outs	<p>Too many start attempts, the control box is locked.</p> <ul style="list-style-type: none"> ▪ Cancel the control box lock, see from page 14. ▪ Check fuel quantity and fuel supply, see from page 36.
051	Cold blowing - time out	<p>On starting the flame sensor signals a temperature >70 °C for longer than 240 sec.</p> <ul style="list-style-type: none"> ▪ Check exhaust and combustion air system. ▪ Check flame sensor, see Fault code 064 and 065.
052	Safety time exceeded	<ul style="list-style-type: none"> ▪ Check exhaust and combustion air system. ▪ Check fuel quantity and fuel supply, see from page 36. ▪ Renew the gauze fuel filter inserted in the connection socket of the metering pump.
053 054 056 057	<p>Flame cutout from "Power" control stage</p> <p>Flame cutout from "High" control stage</p> <p>Flame cutout from "Low" control stage</p> <p>Flame cutout from start process</p> <p>PLEASE NOTE!</p> <p>If start attempts are still allowed, in the event of a flame cutout the heater restarts, if necessary with subsequent repeat start.</p> <p>If the restart or repeated start was successful, the fault code display is deleted.</p>	<ul style="list-style-type: none"> ▪ Check exhaust and combustion air system. ▪ Check fuel quantity and fuel supply, see from page 36. ▪ Check flame sensor, see Fault code 064 and 065.
060	Overheating sensor interruption	<ul style="list-style-type: none"> ▪ Check overheating sensor: <ul style="list-style-type: none"> – Check connector B2 – chamber 10, cable 0.5² sw and chamber 11, cable 0.5² sw for damage. – Remove the overheating sensor and check, see Page 30. – If fault code 060 continues to be displayed, replace the control box.

4 TROUBLESHOOTING

FAULT CODE DISPLAY	FAULT DESCRIPTION	COMMENTS ▪ REMEDIAL ACTION
061	Short circuit in overheating sensor	<ul style="list-style-type: none"> ▪ Check overheating sensor: <ul style="list-style-type: none"> – Check connector B2 – chamber 10, cable 0.5² sw and chamber 11, cable 0.5² sw for damage. – Remove the overheating sensor and check, see Page 30. – If fault code 061 continues to be displayed, replace the control box.
062 063	Printed circuit board sensor – interruption Printed circuit board sensor – short circuit	<ul style="list-style-type: none"> ▪ Replace control box
064	Flame sensor interruption	<ul style="list-style-type: none"> ▪ Check flame sensor: <ul style="list-style-type: none"> – Check connector B2 – chamber 1, cable 0.22² br and chamber 2, cable 0.22² br for damage. – Remove the flame sensor and check, see Page 34. – If fault code 064 continues to be displayed, replace the control box.
065	Short circuit in flame sensor	<ul style="list-style-type: none"> ▪ Check flame sensor: <ul style="list-style-type: none"> – Check connector B2 – chamber 1, cable 0.22² br and chamber 2, cable 0.22² br for damage. – Remove the flame sensor and check, see Page 34. – If fault code 065 continues to be displayed, replace the control box.
069	JE communication error	<ul style="list-style-type: none"> ▪ Check diagnostics cable <ul style="list-style-type: none"> – Connector B1 – chamber 5 and connector S8 – chamber 2, check cable 0.5² bl/ws for continuity, short circuit and damage, if ok ⇒ check the components connected to the diagnostics cable, if ok ⇒ replace the control box.
071	Surface sensor – interruption	<ul style="list-style-type: none"> ▪ Check the surface sensor: <ul style="list-style-type: none"> – Check connector B2 – chamber 7, cable 0.5² ws and chamber 8, cable 0.5² ws for damage. – Remove the surface sensor and check, see Page 31. – If fault code 071 continues to be displayed, replace the control box.
072	Surface sensor – short circuit	<ul style="list-style-type: none"> ▪ Check the surface sensor: <ul style="list-style-type: none"> – Check connector B2 – chamber 7, cable 0.5² ws and chamber 8, cable 0.5² ws for damage. – Remove the surface sensor and check, see Page 31. – If fault code 072 continues to be displayed, replace the control box.
074	Operating lock-out – overheating detected, hardware is defective	<ul style="list-style-type: none"> ▪ Check overheating sensor: <ul style="list-style-type: none"> – Check cable for continuity, short circuit and damage. – Check connector B2 – chamber 10, cable 0.5² sw and chamber 11, cable 0.5² sw for damage. – Remove the overheating sensor and check, see Page 30. – If fault code 074 continues to be displayed, replace the control box. ▪ Cancel the control box lock, see from page 14.
090	Hardware is defective	Replace control box
091	Too many resets	Check voltage supply
092 – 099	Control box defective	Replace control box

5 REPAIR INSTRUCTIONS

The permitted repair work to the heater is described in the "Repair Instructions" chapter. The heater must be removed from the vehicle for the repair work to be carried out.

The heater is assembled in the reverse order, note and follow any additional instructions.

PLEASE NOTE!

After completing all the work and installing the heater in the vehicle, perform a functional check on the heater.

BEFORE WORKING ON THE HEATER, ALWAYS FOLLOW THE RELEVANT SAFETY INSTRUCTIONS



DANGER!

RISK OF INJURY, BURNS AND POISONING!

- Always switch off the heater beforehand and leave it to cool.
- Disconnect the battery.
- The heater must not be operated in closed rooms such as garages or workshops.

Exception:

Exhaust suction available directly at the entry to the exhaust pipe.



CAUTION!

- The seals of dismantled components must be renewed.
- During repair work, check all components for damage and if necessary replace.
- Check connector contacts, plug-in connections and cables for corrosion and damage and if necessary repair.
- Only ever use Eberspächer spare parts if replacements are necessary.
- After working on the coolant circuit the level of the coolant must be checked and if necessary topped up according to the vehicle manufacturer's instructions.
- The coolant circuit must then be vented.
- Operation or the after running of the heater may only be stopped in an emergency (see "EMERGENCY OFF" [Page 6](#)) by interrupting the battery current (risk of heater overheating).

SPECIAL TOOL

AMP RELEASE TOOL

The AMP release tool is used to release plug-in contacts in a connector housing.

This release tool can be ordered directly from AMP.

- For Micro Timer AMP Order No. 0-0539960-1



- For Junior Power Timer AMP Order No. 1-1579007-6



- For standard timer, Junior timer AMP Order No. 1-1579007-4

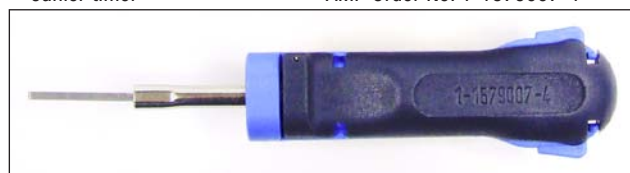

5 REPAIR INSTRUCTIONS

ASSEMBLY DRAWING

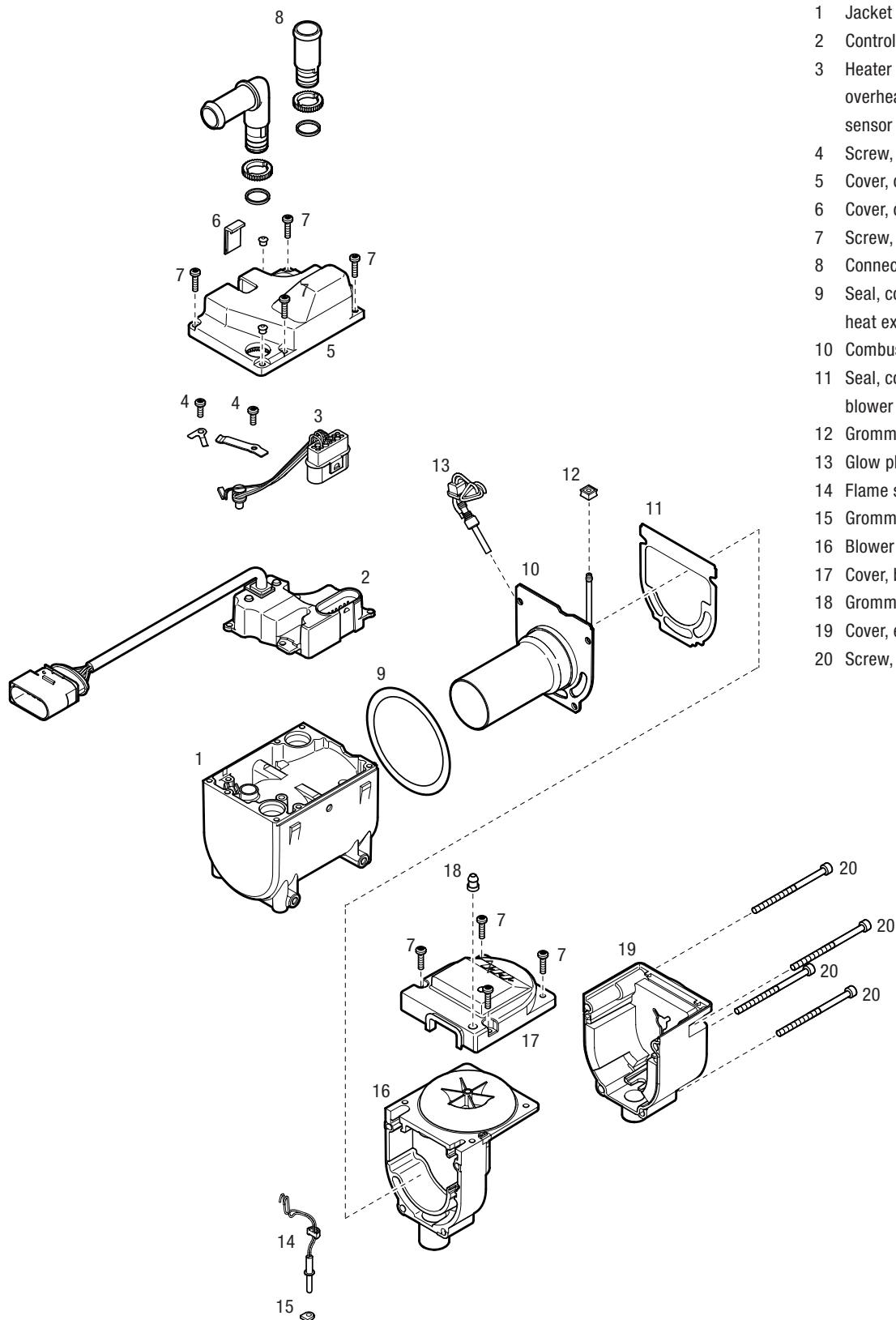

PARTS LIST

- 1 Jacket with heat exchanger
- 2 Control box
- 3 Heater lead harness with overheating sensor and surface sensor
- 4 Screw, M4 x 12 (2x)
- 5 Cover, control box
- 6 Cover, cable, control box
- 7 Screw, M4 x 16 (8x)
- 8 Connecting socket
- 9 Seal, combustion chamber / heat exchanger
- 10 Combustion chamber
- 11 Seal, combustion chamber / blower
- 12 Grommet, fuel pipe
- 13 Glow plug
- 14 Flame sensor
- 15 Grommet, flame sensor
- 16 Blower
- 17 Cover, blower
- 18 Grommet, fuel pipe
- 19 Cover, electric motor
- 20 Screw, M5 x 80 (4x)

5 REPAIR INSTRUCTIONS

REPAIR STEPS

PLEASE NOTE!

This repair instruction describes how to dismantle the heater in individual repair steps. Reference is made to the necessary preceding steps to be performed at the relevant repair steps.

Repair step 1

Remove "control box" cover

[Page 27](#)

Repair step 2

Remove "blower" cover

[Page 27](#)

Repair step 3

Remove connecting sockets from the "control box" cover

[Page 28](#)

Repair step 4

Dismantling the control box

[Page 29](#)

Repair step 5

Remove overheating sensor and surface sensor

[Page 30](#)

Check overheating sensor

[Page 30](#)

Check the surface sensor

[Page 31](#)

Repair step 6

Remove "electric motor" cover and

"Blower sub-assembly with combustion chamber"

[Page 32](#)

Repair step 7

Measure blower speed

[Page 33](#)

Repair step 8

Remove flame sensor

[Page 34](#)

Check flame sensor

[Page 34](#)

Repair step 9

Check glow plug

[Page 35](#)

Dismantle glow plug

[Page 35](#)

CONNECTOR ASSIGNMENT – 10-PIN CONNECTOR S1

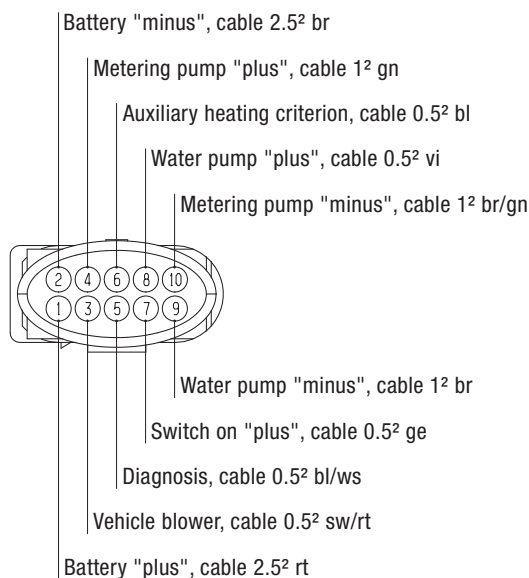

CONNECTOR ASSIGNMENT – 14-PIN CONNECTOR B2

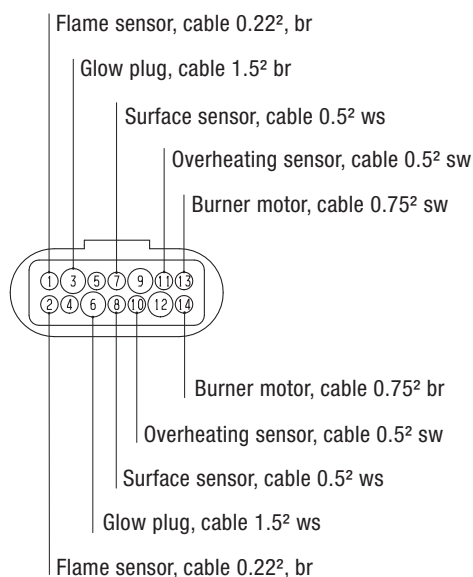

Connector housings are shown from the cable inlet side.

5 REPAIR INSTRUCTIONS

DISMANTLE THE HEATER

REPAIR STEP 1

REMOVE "CONTROL BOX" COVER

- Unscrew the 4 fixing screws M4 x 16 in the "control box" cover.
- Unlock cover of "control box cable" by turning in direction of arrow (A), pull out of the "control box" cover from the top.
- Keep the "control box cable" cover in a safe place for the assembly.
- If an angle connector has been installed, mark the setting.
- Lift up "control box" cover and carefully pull the water connection socket out of the jacket.
- Remove "control box" cover.

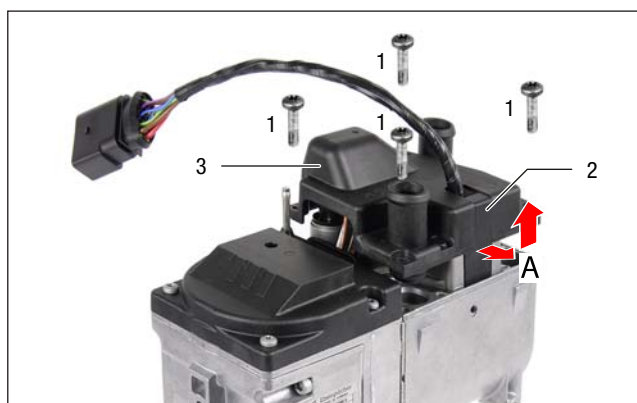

- 1 Fixing screws M4 x 16
- 2 "Control box cable" cover
- 3 "Control box" cover

PLEASE NOTE!

NOTES FOR THE ASSEMBLY:

- Before installing the "control box" cover, ensure that the toothed rings of both connection sockets are correctly locked in the cover.
- Insert the "control box cable" cover in the "control box" cover.
- Tightening torque of the fixing screws:
M4 x 16 = $2.9^{+0.3}$ Nm

REPAIR STEP 2

Remove "blower" cover

To dismantle the "blower" cover, perform [Repair step 1](#) first.

- Unscrew the 4 fixing screws M4 x 16 in the "blower" cover.
- Carefully remove the "blower" cover above the fuel connection.

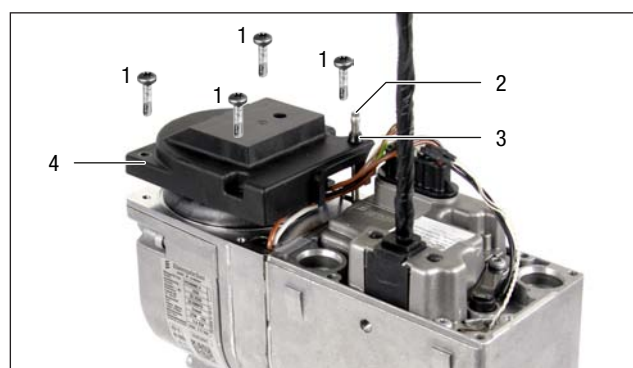

- 1 Fixing screws M4 x 16
- 2 Fuel pipe
- 3 "Fuel pipe" grommet in the "blower" cover
- 4 "Blower" cover

PLEASE NOTE!

NOTES FOR THE ASSEMBLY:

- Renew the grommet for the fuel connection in the "blower" cover, the grommet is included in the relevant spare parts kit.
- Carefully position the "blower" cover above the fuel connection on the blower housing, do not clamp the cable between the cover and housing.
- Ensure the "fuel connection" grommet fits correctly in the "blower" cover.
- Ensure the "electric motor cable loom" grommet fits correctly in the blower housing.



- 1 Grommet "Electric motor cable loom"

- Tightening torque of the fixing screws:
M4 x 16 = $2.9^{+0.3}$ Nm

5 REPAIR INSTRUCTIONS

REPAIR STEP 3

REMOVE CONNECTING SOCKETS FROM THE "CONTROL BOX" COVER

To dismantle the connection sockets from the "control box" cover, perform [Repair step 1](#) first.

- Push down the connecting socket in the "control box" cover.
- Loosen toothed ring.
- Remove O-ring.
- Pull out connection socket from the "control box" cover from above.



- 1 "Control box" cover
- 2 Water connection socket
- 3 Toothed ring
- 4 O-ring

PLEASE NOTE!

NOTES FOR THE ASSEMBLY:

- Insert the connection socket in the "control box" cover from above.
- Insert O-ring in the groove of the connection socket.
- Fit the toothed ring onto the connection socket and insert in the ring gear of the "control box" cover. If an angled connection socket was fitted, the angled connection socket must be aligned according to the installation position or the marking and inserted in the gear ring of the "control box" cover.

5 REPAIR INSTRUCTIONS

REPAIR STEP 4

DISMANTLING THE CONTROL BOX

To dismantle the "control box", perform [Repair step 1](#) first.

- Unlock the locking tab at the 14-pin connector (B2) by turning in direction of arrow (A).
- Pull off the 14-pin connector (B2) from above.

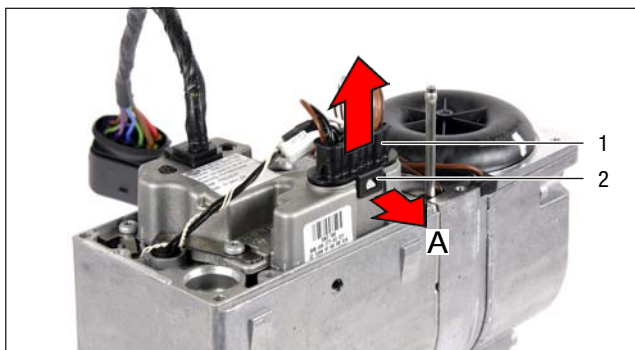

- 1 14-pin connector (B2)
- 2 Locking tab

- Undo fixing screw M4 x 12 compression spring overheating sensor / control box. Remove the compression spring.



- 1 Fixing screw M4 x 12

- Undo fixing screw M4 x 12 compression spring surface sensor / control box. Remove the compression spring.



- 1 Fixing screw M4 x 12

- Remove the control box.

PLEASE NOTE!

The overheating sensor does not have to be removed.

NOTES FOR THE ASSEMBLY:

- Tightening torque of the fixing screws:
M4 x 12 = $3.3^{+0.3}$ Nm

5 REPAIR INSTRUCTIONS

REPAIR STEP 5

REMOVE OVERHEATING SENSOR AND SURFACE SENSOR

To remove the overheating sensor / surface sensor, perform [Repair step 1](#) and [Repair step 4](#) first.

- Use flat pliers to pull the overheating sensor out of the locator hole in the jacket. Remove overheating sensor, surface sensor and the 14-pin connector (B2).

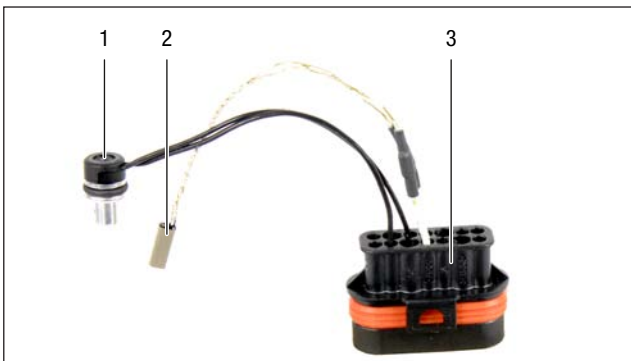

- Overheating sensor
- Surface sensor
- 14-pin connector (B2)

PLEASE NOTE!

The overheating sensor, surface sensor and 14-pin connector are a sub-assembly and are not available as individual parts.

- If replacing the overheating sensor, surface sensor and 14-pin connector (B2) the plug-in contacts of the
 - electric motor, chamber 13, cable 0.75² sw and chamber 14, cable 0.75² br
 - flame sensor, chamber 1, cable 0.22² br and chamber 2, cable 0.22² br
 - glow plug, chamber 3, cable 1.5² br and chamber 6, cable 1.5² ws must be unclipped from the existing 14-pin connector (B2).
- It is advisable to mark the unclipped cables or to take into account the connector assignment in [Page 26](#).

PLEASE NOTE!

NOTES FOR THE ASSEMBLY:

- The following parts are included in the spare parts kit and must be used:
 - Compression spring, overheating sensor
 - Compression spring, surface sensor
 - M4 x 12 screw (2x)
- When installing, twist the overheating sensor lead harness and the surface sensor lead harness.

CHECK OVERHEATING SENSOR

- Check the overheating sensor using a digital multimeter in the 14-pin connector (B2) in chamber 10 and 11. If the resistance value lies outside the diagram or the table of values, replace the overheating sensor.

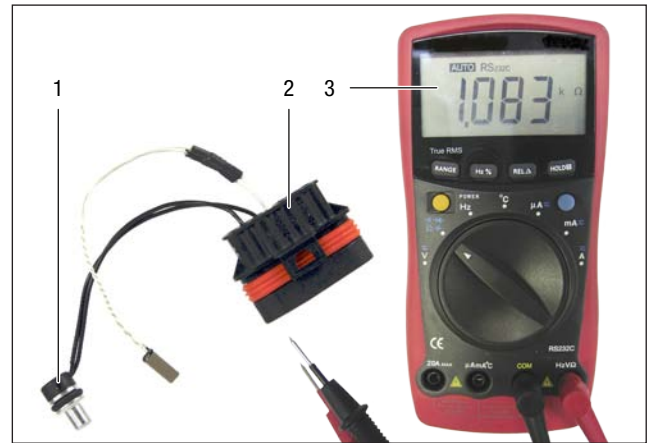

- Overheating sensor
- 14-pin connector (B2)
- Digital multimeter

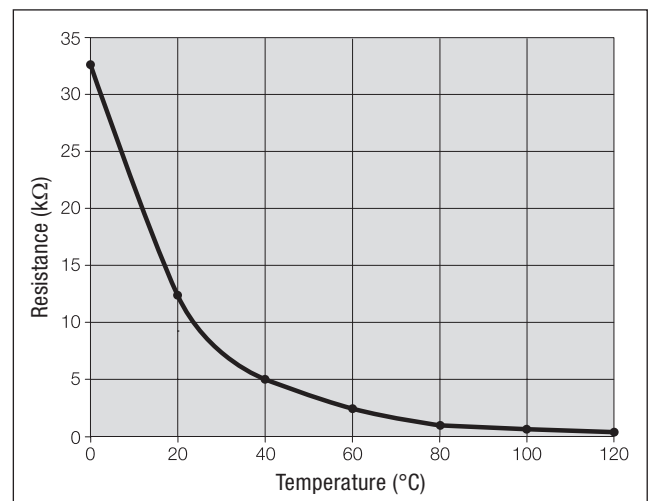

TABLE OF VALUES

Temp [°C]	R [kΩ]	Temp [°C]	R [kΩ]
0	32.54 ± 2.2	70	1.75 ± 0.13
10	19.87 ± 1.0	80	1.25 ± 0.1
20	12.48 ± 0.5	90	0.91 ± 0.08
30	8.06 ± 0.4	100	0.67 ± 0.06
40	5.33 ± 0.3	110	0.50 ± 0.05
50	3.60 ± 0.25	120	0.38 ± 0.04
60	2.48 ± 0.17		

5 REPAIR INSTRUCTIONS

REPAIR STEP 5

CHECK THE SURFACE SENSOR

- Check the surface sensor using a digital multimeter in the 14-pin connector (B2) in chamber 7 and 8. If the resistance value lies outside the diagram or the table of values, replace the surface sensor.



- Surface sensor
- 14-pin connector (B2)
- Digital multimeter

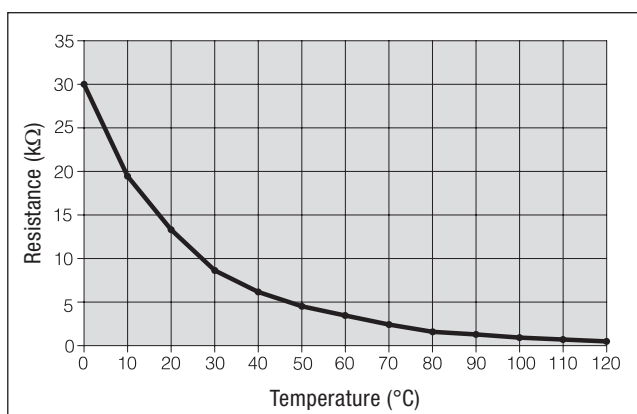

TABLE OF VALUES

Temp [°C]	R [kΩ]
0	30.00 ± 1.50
25	10.74 ± 0.78
40	6.20 ± 0.52
60	3.19 ± 0.32
80	1.75 ± 0.20
100	1.02 ± 0.13
120	0.62 ± 0.08

5 REPAIR INSTRUCTIONS

REPAIR STEP 6

REMOVE THE "ELECTRIC MOTOR" COVER AND "BLOWER SUB-ASSEMBLY WITH COMBUSTION CHAMBER"

To remove the "electric motor" cover and "blower sub-assembly with combustion chamber", perform [Repair step 1](#), [Repair step 2](#) and [Repair step 4](#) first.

- Unlock plug-in contacts from electric motor in the 14-pin connector (B2), chamber 13, cable 0.75² sw and chamber 14, cable 0.75² br using the AMP release tool.
- Unlock plug-in contacts from flame sensor in the 14-pin connector (B2), chamber 1, cable 0.22² br and chamber 2, cable 0.22² br using the AMP release tool.
- Unlock plug-in contacts from glow plug in the 14-pin connector (B2), chamber 3, cable 1.5² br and chamber 6, cable 1.5² ws using the AMP release tool.

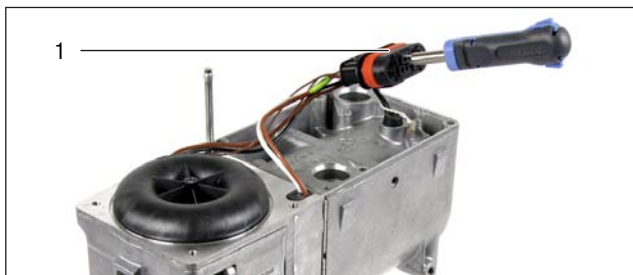

1 14-pin connector (B2)

- Unscrew the 4 fixing screws M5 x 80 of the "electric motor" cover and the blower.

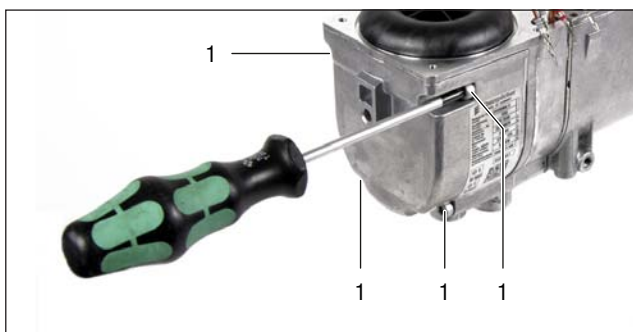

1 Fixing screw M5 x 80

- Remove "electric motor" cover.
- Pull the "Blower with combustion chamber" sub-assembly out of the heat exchanger.

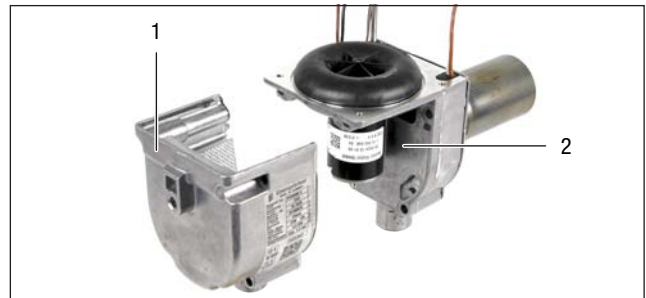

1 Electric motor cover

2 "Blower with combustion chamber" sub-assembly

- Remove the combustion chamber from the blower housing, at the same time pull off the grommet from the glow plug and the grommet from the fuel tube from the blower housing together with the combustion chamber.

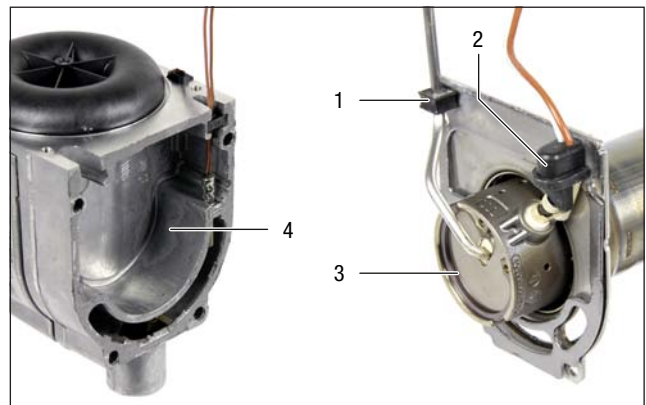

1 Fuel pipe grommet

2 Glow plug cable loom grommet

3 Combustion chamber

4 Blower housing with flame sensor

5 REPAIR INSTRUCTIONS

REMOVE THE "ELECTRIC MOTOR" COVER AND "BLOWER SUB-ASSEMBLY WITH COMBUSTION CHAMBER"

- Remove seal between the combustion chamber flange and the blower housing or between the combustion chamber flange and the heat exchanger, carefully clean all sealing surfaces.
- Pull grommet off the fuel pipe.

CAUTION!

Reusing the dismantled seals and grommets can result in leaks and malfunctions in the heater.

→ Use the specified spare parts kit.

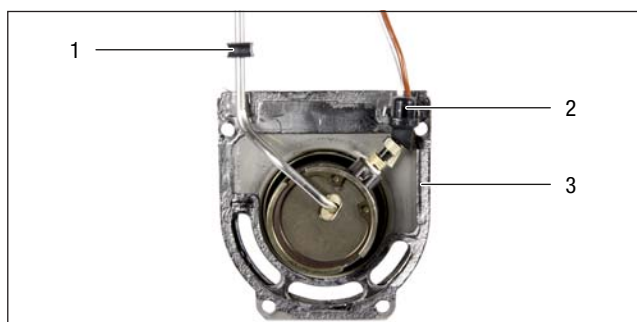

- 1 Grommet, fuel pipe in blower housing
- 2 Grommet, glow plug in blower housing
- 3 Seal, combustion chamber flange / blower housing

PLEASE NOTE!

NOTES FOR THE ASSEMBLY:

- The following parts are included in the spare parts kit and must be used:
 - Grommet, fuel pipe
 - Grommet, fuel pipe in the "blower" cover
 - Grommet, flame sensor
 - Seal, between the combustion chamber and the blower housing
 - Seal (round), between the combustion chamber and the heat exchanger
- Position new seal between the blower housing and combustion chamber on the combustion chamber flange, note the different cut-outs in the seal.
- Position the "glow plug cable loom" grommet with its flat surface on the seal (combustion chamber flange).
- Push on the grommet for the fuel pipe and position on the seal (combustion chamber flange).
- When assembling the combustion chamber and blower housing, always ensure the grommets sit properly.
- insert new seal between the combustion chamber and the heat exchanger, in the circular recess of the jacket and heat exchanger.
- Tightening torque of the fixing screws:
M5 x 80 = 6.5^{+0.5} Nm

REPAIR STEP 7

MEASURE BLOWER SPEED

To measure the blower speed, perform [Repair step 1](#), [Repair step 2](#) and [Repair step 4](#) first.

- Apply a marking (white paint) to the impeller and measure the speed using a non-contact r.p.m. counter.
- Apply max. 8.2 V at the 14-pin connector (B2), chamber 13, cable 0.75² sw and chamber 14, cable 0.75² br.
- If the measured speed <10 000 rpm, then replace the combustion air fan.
- If the measured speed > 10 000 rpm, then replace the control box.

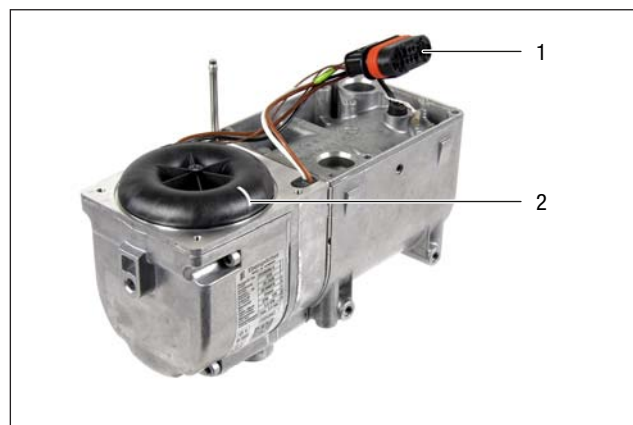

- 1 14-pin connector (B2)
- 2 Marking

5 REPAIR INSTRUCTIONS

REPAIR STEP 8

REMOVE FLAME SENSOR

To remove the flame sensor, perform [Repair step 1](#), [Repair step 2](#) and [Repair step 4](#) and [Repair step 6](#) first.

- Pull the flame sensor cable loom grommet out of the groove.
- Pull out the flame sensor together with the grommet (graphite grommet) from the groove in the blower housing.
- Remove the flame sensor.

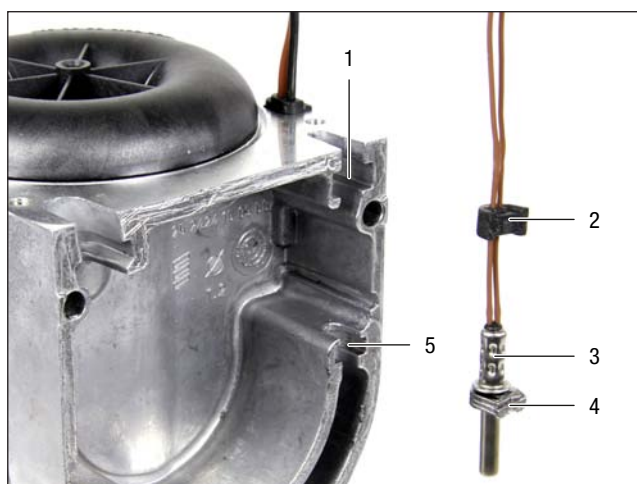

- 1 Groove, "Flame sensor cable loom" grommet and "fuel pipe" grommet
- 2 "Flame sensor cable loom", semi-round
- 3 Flame sensor
- 4 Flame sensor grommet (graphite grommet)
- 5 Flame sensor collar grommet and graphite grommet

PLEASE NOTE!

NOTES FOR THE INSTALLATION:

- The following parts are included in the spare parts kit and must be used:
 - Grommet, fuel pipe
 - Grommet, fuel pipe in the "blower" cover
 - Grommet, flame sensor (graphite grommet)
 - Seal, between the combustion chamber flange and the blower housing
 - Seal, between the combustion chamber flange and the heat exchanger

NOTES FOR THE ASSEMBLY:

- Insert the flame sensor cable loom grommet with the rounding in the upper housing groove of the fan.
- Push the grommet, flame sensor (graphite grommet) onto the flame sensor.
- Push the collar of the flame sensor and the flame sensor grommet (graphite grommet with rounding) together into the groove of the fan housing.

CHECK FLAME SENSOR

Check the flame sensor using a digital multimeter. If the resistance value of the flame sensor lies outside the diagram or the table of values, replace the flame sensor.



- 1 Flame sensor
- 2 Digital multimeter

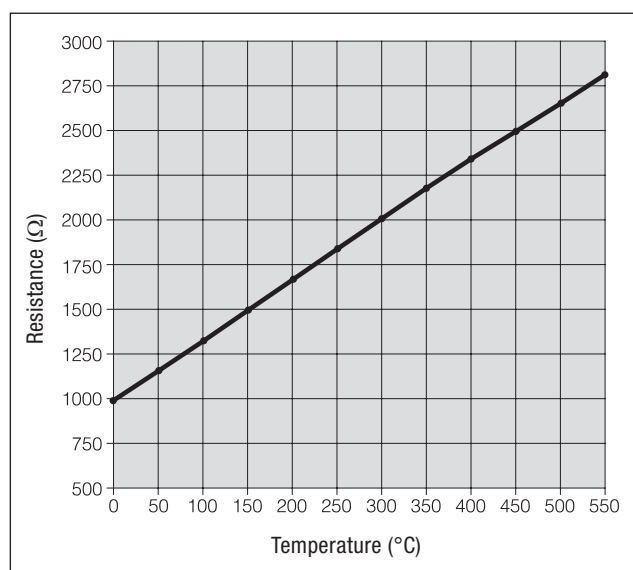

TABLE OF VALUES

Temp [°C]	R [Ω]	Temp [°C]	R [Ω]
0	1000 ± 10	200	1758 ± 24
50	1194 ± 12	250	1941 ± 28
100	1385 ± 15	300	2120 ± 32
150	1573 ± 20	350	2297 ± 36

5 REPAIR INSTRUCTIONS

REPAIR STEP 9

CHECK GLOW PLUG

To check the glow plug, perform [Repair step 1](#) and [Repair step 2](#) first.

- Unlock the locking tab at the 14-pin connector (B2) by turning in direction of arrow (A).
- Pull off the 14-pin connector (B2) from above.

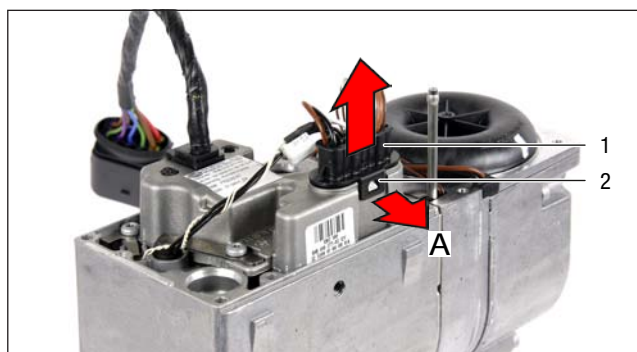

- 1 14-pin connector (B2)
- 2 Locking tab

- Check glow plug in installed condition.
 - Connector B2 – chamber 3, cable 1.5² br and chamber 6, cable 1.5² ws, unclip both cables.
 - Apply 8 V \pm 0.1 V voltage to the glow plug and after 25 sec measure the current intensity.
 - If 8.5 A (+1 A / -1.5 A) the glow plug is ok.
- If values are different, remove the glow plug.

DISMANTLE GLOW PLUG

To remove the glow plug, perform [Repair step 1](#), [Repair step 2](#) and [Repair step 6](#) first.

- Carefully pull the glow plug out of the combustion chamber and renew.

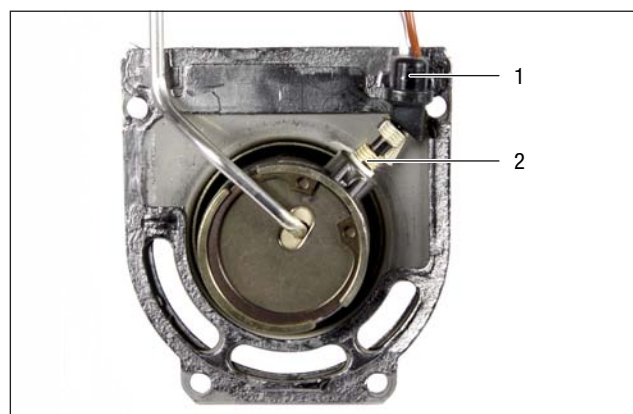

- 1 Grommet, glow plug
- 2 Glow plug

PLEASE NOTE!

NOTES FOR THE ASSEMBLY:

- The following parts are included in the spare parts kit and must be used:
 - Grommet, fuel pipe
 - Grommet, fuel pipe in the "blower" cover
 - Grommet, flame sensor (graphite grommet)
 - Seal, between the combustion chamber flange and the blower housing
 - Seal, between the combustion chamber flange and the heat exchanger

5 REPAIR INSTRUCTIONS

MEASURING THE FUEL QUANTITY, WITHOUT EDITH BASIC

PREPARING FOR THE MEASUREMENT

- Remove the fuel pressure pipe from the heater and insert a measuring cylinder (size 25 cm³).
- Switch on heater.
- Depending on the heater type, the metering pump starts pumping fuel after 17 to 20 sec. If the fuel comes out uniformly and free of bubbles, the fuel pipe is filled and vented.
- Switch off heater and empty measuring cylinder.

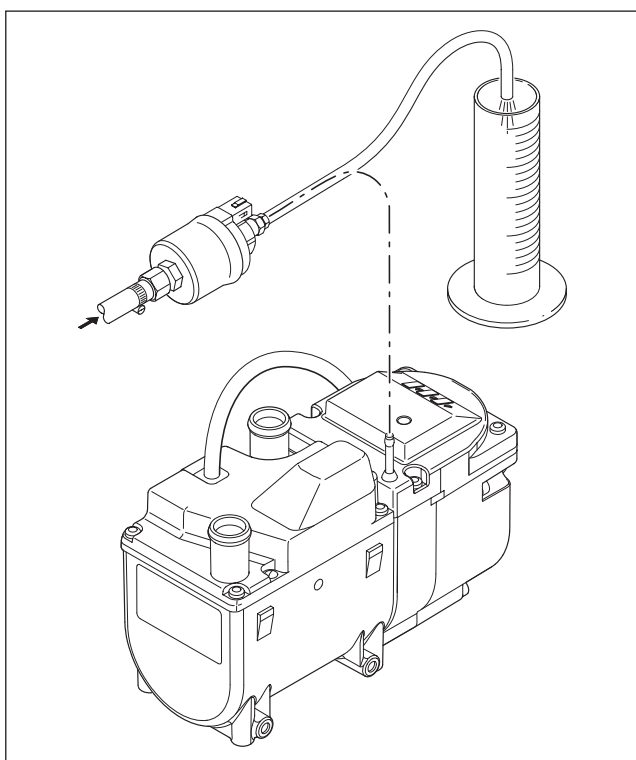

MEASUREMENT

- Switch on heater.
- Depending on the heater type, the metering pump starts pumping fuel after 17 to 20 sec.
- During the measurement, hold the measuring cylinder at the level of the heater.
- Petrol heaters
Because of the delivery rate, it is sufficient to start once to measure the fuel quantity of petrol / ethanol heaters.
In the case of diesel heaters, after starting once, two automatic start repeats must take place to obtain sufficient fuel for the measurement.
- After measuring, switch off the heater.
- Read off the quantity of fuel in the measuring cylinder.

EVALUATION

- Compare the measured quantity of fuel with the values in the following table.
If the measured quantity of fuel is above the maximum value or below the minimum value, the metering pump must be replaced.

Heater type	Hydronic II		
	B 4 S / B 5 S	D 4 S / D 5 S	E 4 S
Heater version			
Delivery period			
one-off start	80 Sec.		80 Sec.
one start + two repeats		129 Sec.	
Fuel quantity – nominal. [cm ³]	12.4	8.2	13.5
Fuel quantity – max. [cm ³]	13.7	9.0	14.6
Fuel quantity – min. [cm ³]	11.2	7.4	12.5

PLEASE NOTE!

Only carry out the fuel measurement if the battery is sufficiently charged. During the measurement at least 12 volt or max. 13 volt should be applied to the control box.

MEASURING THE FUEL QUANTITY, WITH EDITH BASIC

PREPARING FOR THE MEASUREMENT

- Remove the fuel pressure pipe at the heater and insert a measuring cylinder (size 25 cm³).
- Connect heater to EDiTH Basic (ISO adapter) and select "switch on component" function at the PC.
- Select "metering pump" component, click "Run" button and pump fuel into the measuring cylinder.
Retain setting of 30 sec. delivery period with 10 Hz metering pump frequency.
- After 30 sec. the metering pump switches off, empty the measuring cylinder.

MEASUREMENT / EVALUATION

- Switch on the "metering pump" component again via EDiTH and pump into the measuring cylinder, delivery period 30 sec. with 10 Hz metering pump frequency.
- After 30 sec. the metering pump is switched off, read off the quantity of fuel in the measuring cylinder.

Heater type	Hydronic II		
	B 4 S / B 5 S	D 4 S / D 5 S	E 4 S
Heater version			
Delivery period in sec.	30		
Frequency [hz]	10		
Fuel quantity – nominal. [cm ³]	8.2	8.9	9.4
Fuel quantity – max. [cm ³]	9.0	9.8	10.7
Fuel quantity – min. [cm ³]	7.7	8.4	8.6

6 ELECTRICS / CIRCUIT DIAGRAM

HEATER WIRING



CAUTION!

SAFETY INSTRUCTIONS FOR WIRING THE HEATER!

The heater is to be connected up electrically according to the EMC directives. EMC can be affected if the heater is not connected up correctly. For this reason, comply with the following instructions:

- Ensure that the insulation of electrical cables is not damaged.
- Avoid:
 - chafing, kinking, jamming or exposure to heat.
 - Seal any connector chambers of watertight connectors not in use with filler plugs to ensure they are dirt-proof and water-proof.
 - Electrical connections and ground connections must be free of corrosion and firmly connected.
 - Lubricate connections and ground connections outside the heater interior with contact grease.

PLEASE NOTE!

Comply with the following when wiring the heater and the control unit:

- Electrical leads and components must be positioned in the vehicle so that they can function perfectly under normal operating conditions without impairment (e.g. due to heat exposure, moisture, etc.).
- The following cable cross section is to be used between the battery and heater. This ensures that the max. permissible voltage drop in the cables does not exceed 0.5 V for 12 V rated voltage.
 - Cable cross-section for a cable length (plus cable + minus cable) up to 6 m = cable cross-section 4 mm².
- If the positive cable is to be connected to the fuse box (e.g. terminal 30), the vehicle's cable from the battery to the fuse box must also be included in the calculation for the total cable length and re-dimensioned if necessary.
- Insulate unused cable ends.

PARTS LIST FOR HEATER CIRCUIT DIAGRAM

- 1.1 Burner motor
- 1.2 Glow plug
- 1.5 Control - overheating sensor
- 1.12 Flame sensor
- 1.13 Surface sensor
- 2.1 Control box
- 2.2 Fuel metering pump
- 2.5.7 Vehicle blower relay
- 2.7 Main fuse, 20 A
- 2.7.1 Activation fuse, 5 A
- 2.7.5 Vehicle blower fuse, 25 A
- 2.12 Water pump
- 5.1 Battery
- b) Vehicle blower connection
- g) For S heater
- h) For SC heater
- k) Temperature switch (< 5 °C)

PLEASE NOTE!

The relay, 12 volt 2.5.7 (from terminal 30 to terminal 87a) has a maximum power consumption of 40 A; i.e. the value of the vehicle's own blower fuse may not be more than 40 A. For circuit diagram, see [Page 38](#).

ASSIGNMENT OF CONNECTOR S1

Chamber	Cross-section	Colour	Function
1	2.5	red	Battery "plus" (positive) (terminal 30)
2	2.5	brown	Battery "minus" (negative) (terminal 31)
3	0.5	black / red	Vehicle fan
4	1.0	green	Metering pump "Plus"
5	0.5	blue / white	JE diagnosis
6	0.5	blue	Auxiliary heating criterion
7	0.5	yellow	Switch on "Plus"
8	0.5	violet	Water pump "Plus"
9	1.0	brown	Water pump "Minus"
10	1.0	brown / green	Metering pump "Minus"

CABLE COLOURS

rt	red	gr	grey
bl	blue	ge	yellow
ws	white	vi	violet
sw	black	br	brown
gn	green		

Connectors and bush housings are shown from the cable inlet side.

6 ELECTRICS / CIRCUIT DIAGRAM

HEATER CIRCUIT DIAGRAM

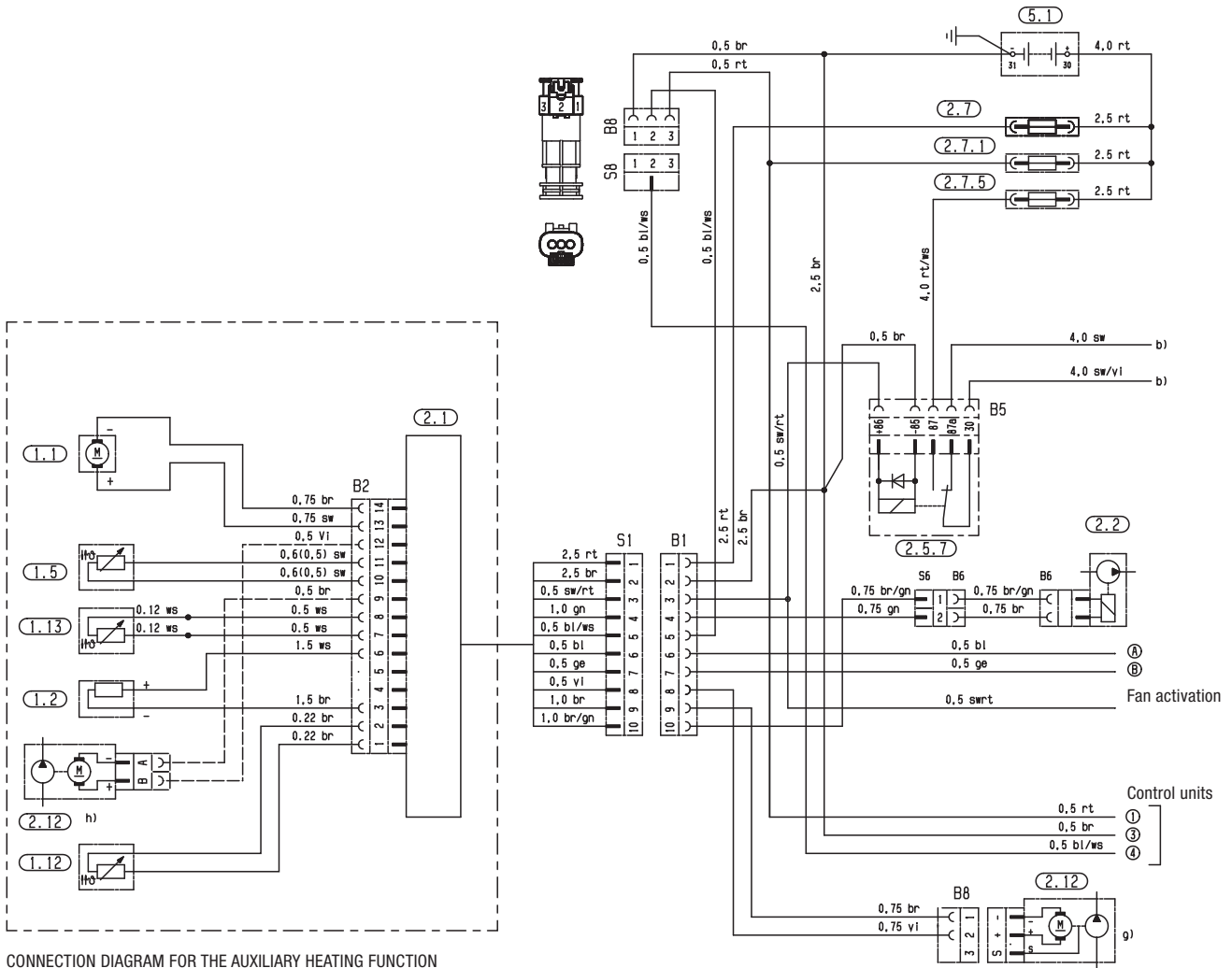

CONNECTION DIAGRAM FOR THE AUXILIARY HEATING FUNCTION

Variant 1: For EasyStart control units

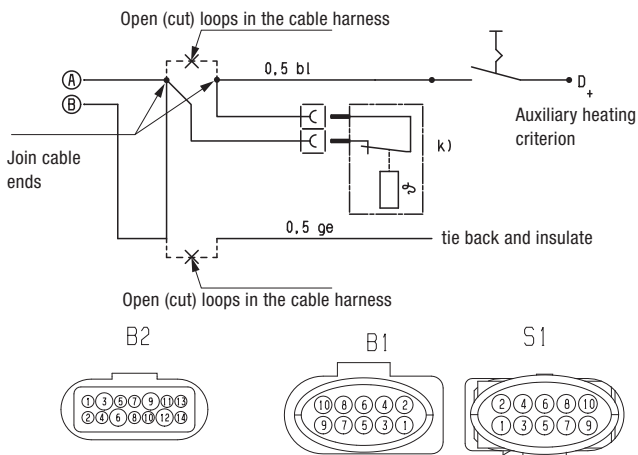

Variant 2: All control units except EasyStart

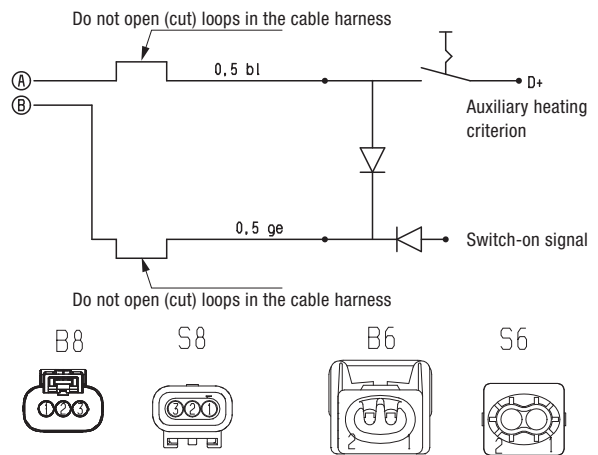

6 ELECTRICS / CIRCUIT DIAGRAM

CIRCUIT DIAGRAM CONTROL UNIT – EASYSTART R+

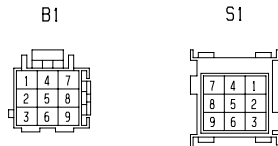
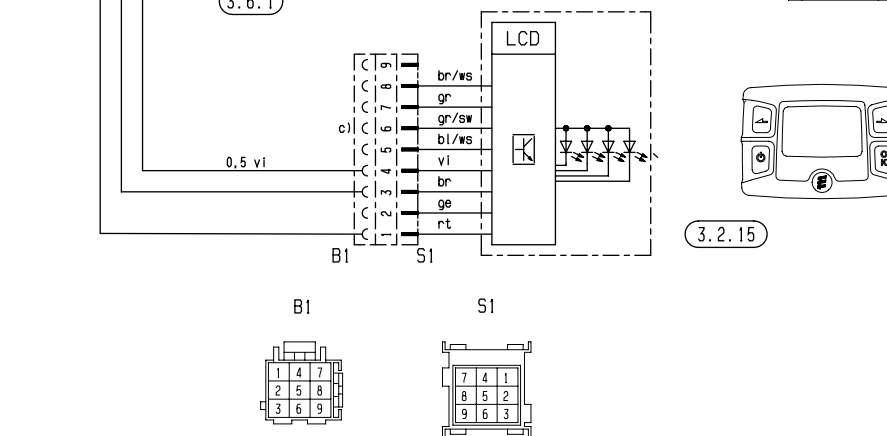
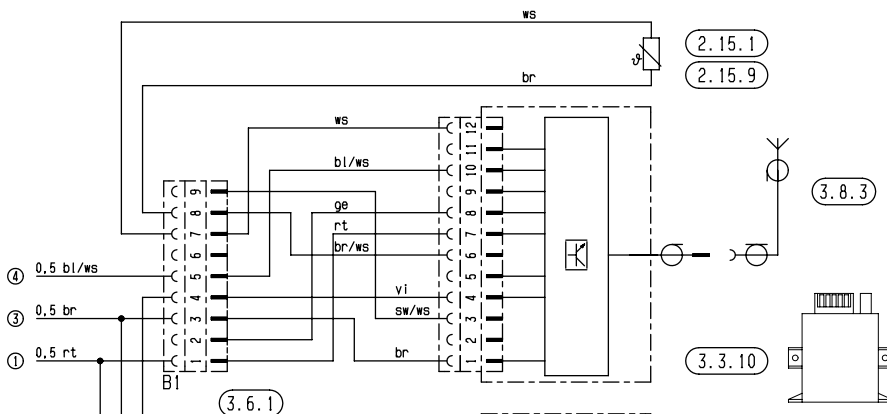
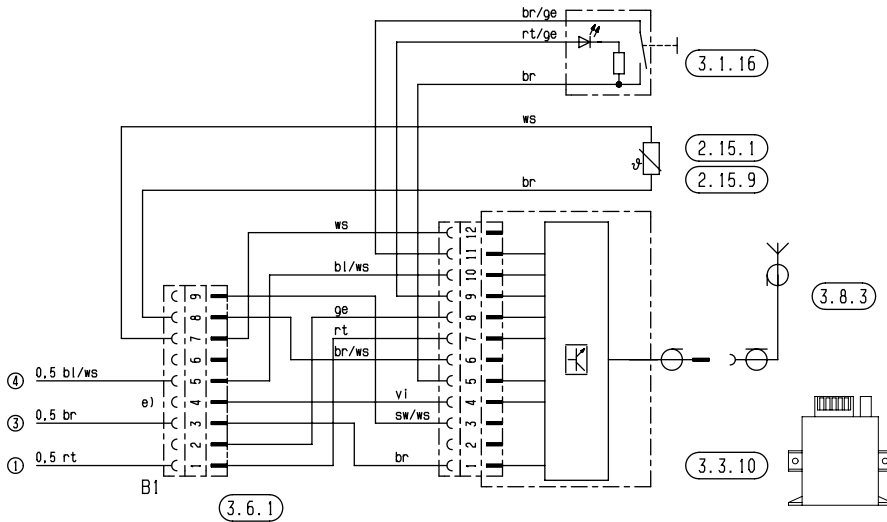

PARTS LIST

- 2.15.1 Room temperature sensor
- 2.15.9 Temperature sensor (outside temperature) (optional)
- 3.1.16 Radio remote control button
- 3.2.15 EasyStart T timer
- 3.3.10 EasyStart R+ radio remote control (stationary unit)
- 3.6.1 Lead harness

- 3.8.3 Antenna
- c) Terminal 58 (lighting)
- e) EasyStart T timer connection

Connectors and bush housings are shown from the cable inlet side.

6 ELECTRICS / CIRCUIT DIAGRAM

CIRCUIT DIAGRAM CONTROL UNIT – EASYSTART R

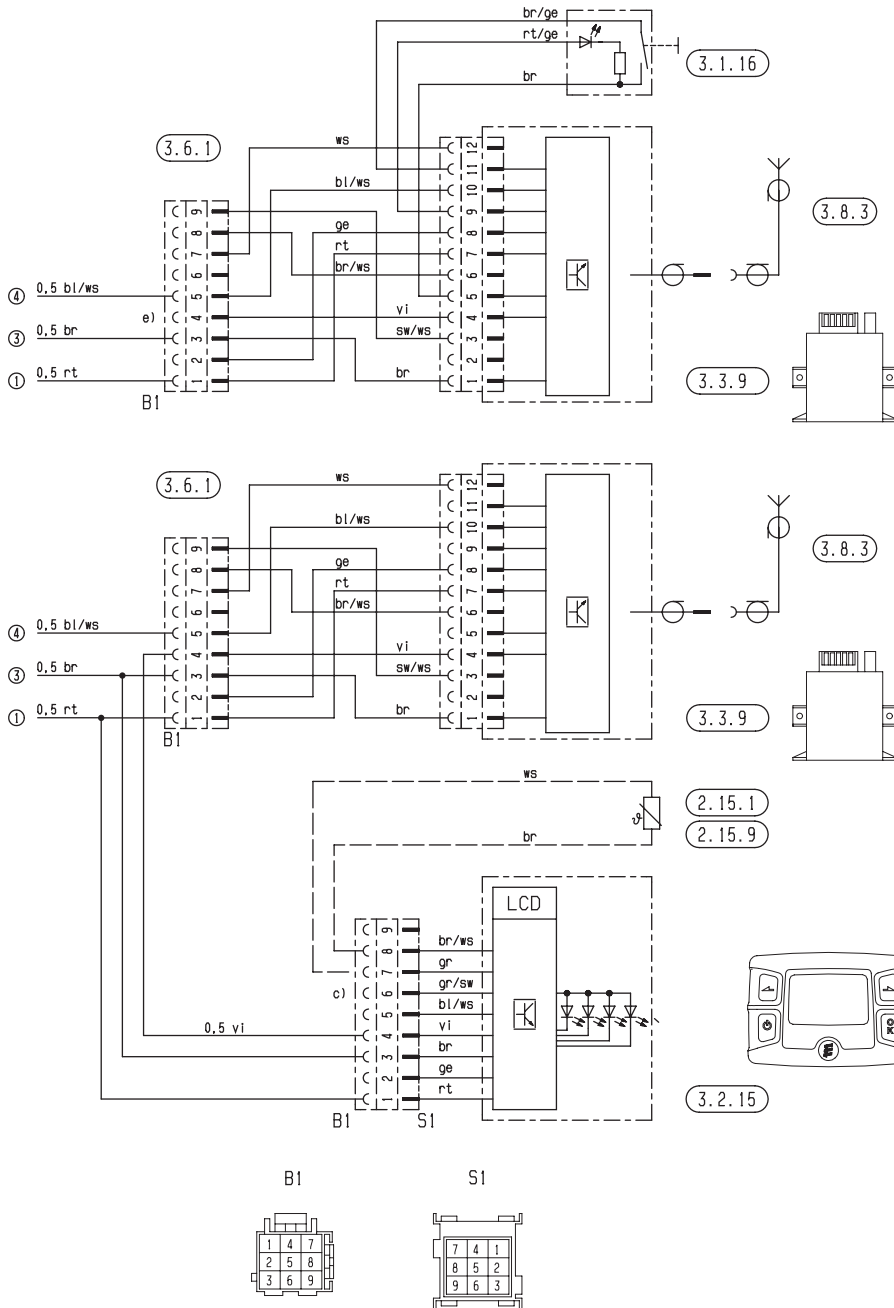

25 2281 00 97 02 A

PARTS LIST

- 2.15.1 Room temperature sensor (optional)
- 2.15.9 Temperature sensor (outside temperature) (optional)
- 3.1.16 Radio remote control button
- 3.2.15 EasyStart T timer
- 3.3.9 EasyStart R+ radio remote control (stationary unit)
- 3.6.1 Lead harness

- 3.8.3 Antenna
- c) Terminal 58 (lighting)
- e) EasyStart T timer connection

Connectors and bush housings are shown from the cable inlet side.

6 ELECTRICS / CIRCUIT DIAGRAM

CIRCUIT DIAGRAM CONTROL UNIT – EASYSTART T

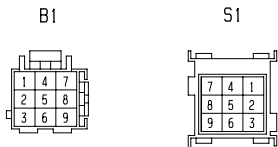
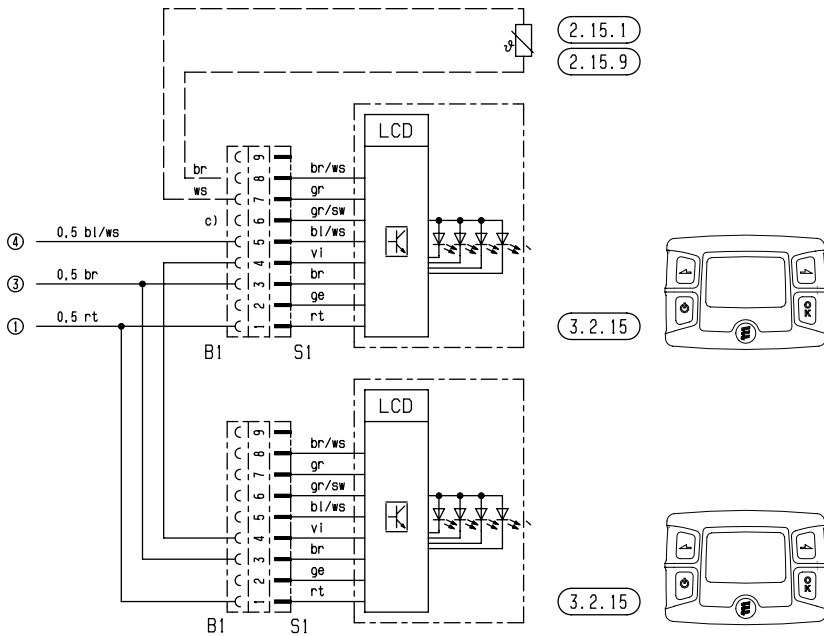
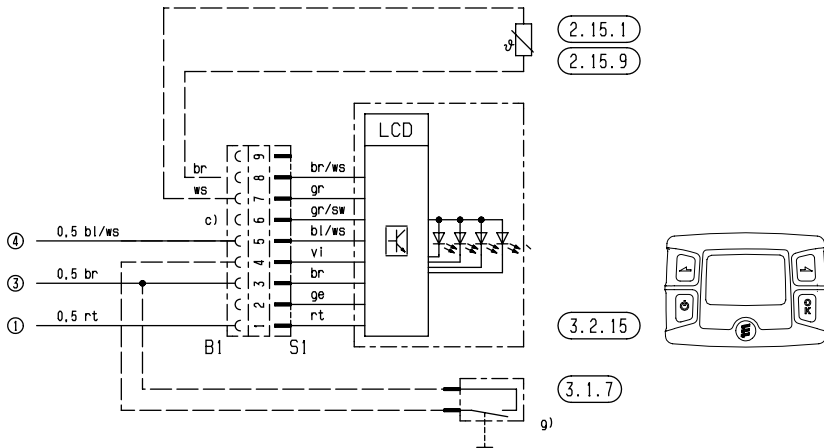

25 2281 00 97 03 A

PARTS LIST

- 2.15.1 Room temperature sensor (optional)
- 2.15.9 Temperature sensor (outside temperature) (optional)
- 3.1.7 "OFF" button
- 3.2.15 EasyStart T timer
- c) Terminal 58 (lighting)
- g) External "ON / OFF" button (optional)

Connectors and bush housings are shown from the cable inlet side.

6 ELECTRICS / CIRCUIT DIAGRAM

CIRCUIT DIAGRAM FOR CONTROL UNIT – CALLTRONIC II

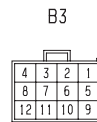
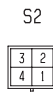
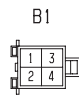
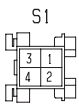
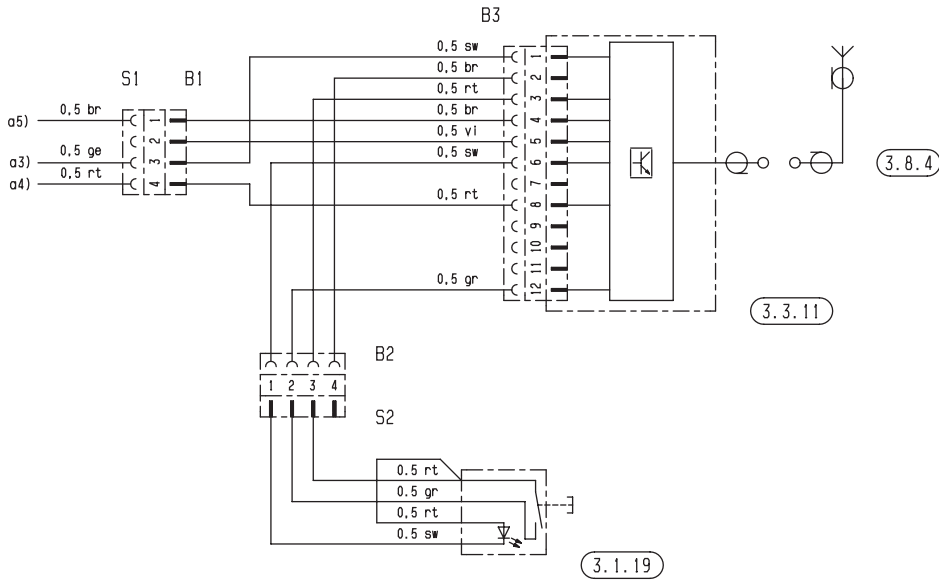

25 2507 00 97 02

PLEASE NOTE!

The "ventilation" function is not available.

PARTS LIST

- 3.1.19 Button, Calltronic II
- 3.3.11 Calltronic II
- 3.8.4 Antenna, screwed

6 ELECTRICS / CIRCUIT DIAGRAM

CIRCUIT DIAGRAM FOR CONTROL UNIT – EASYSTART CALL

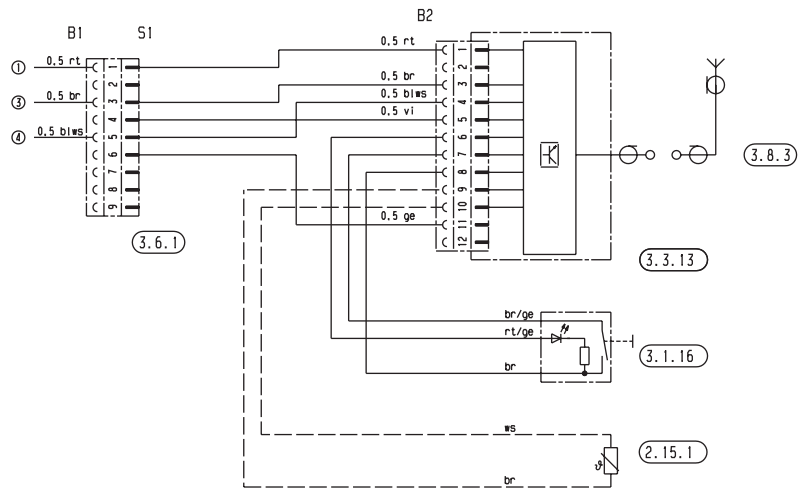

S1



B1



B2

25 2526 97 00 02

PARTS LIST

- 2.15.1 Room temperature sensor (optional)
- 3.1.16 Button
- 3.3.13 EasyStart Call
- 3.6.1 Adapter
- 3.8.3 Antenna

7 SERVICE

CERTIFICATIONS

The high quality of Eberspächer's products is the key to our success. To guarantee this quality, we have organised all work processes in the company along the lines of quality management (QM). Even so, we still pursue a large number of activities for continuous improvement of product quality in order to keep pace with the similarly constantly growing requirements made by our customers.

All the steps necessary for quality assurance are stipulated in international standards.

This quality is to be considered in a total sense. It affects products, procedures and customer / supplier relationships.

Officially approved public experts assess the system and the corresponding certification company awards a certificate.

Eberspächer has already qualified for the following standards:

QUALITY MANAGEMENT AS PER

EN ISO 9001:2000 AND ISO/TS 16949:1999

ENVIRONMENTAL MANAGEMENT SYSTEM AS PER

EN ISO 14001:1996

DISPOSAL

DISPOSAL OF MATERIALS

Old devices, defect components and packaging material can all be separated and sorted into pure-grade fractions so that all parts can be disposed of as required in an environment-friendly manner recycled where applicable.

Electric motors, control boxes and sensors (e.g. temperature sensors) are deemed to be "electronic scrap".

DISMANTLING THE HEATER

The heater is dismantled according to the repair stages in the current troubleshooting / repair instructions.

PACKAGING

The packaging of the heater can be kept in case it has to be sent back.

EC DECLARATION OF CONFORMITY

The manufacturer:

J. Eberspächer GmbH & Co. KG

Address:

Eberspächerstraße 24
D-73730 Esslingen

herewith declares that the following product:

Product name	Vehicle heater
Type	Hydronic II
Version	B 4 S / B 5 S D 4 S / D 5 S / E 4 S

fulfils the requirements of the following EC Directives:

- Heating systems directive 2001/56/EC,
Revision status 2006/119/EC
- Radio interference (EMC) of vehicles 72/245/EEC,
Revision status 2006/96/EC
- Heater control ECE-R 122,
Revision status 00
- EMC of vehicles ECE-R 10,
Revision status 03

The following EC Directives and UN regulations have been used to assess the product: 2001/56/EC; 72/245/EEC; ECE-R 10; ECE-R 122

7 SERVICE

LIST OF KEY WORDS

A

Accident prevention [6](#)
 Adapter cable [15](#)
 AMP release tool [24](#)
 Assembly drawing [25](#)
 Assignment of connector S1 [37](#)

B

Battery voltage [14](#)
 bioethanol heater [9](#)
 Blower sub-assembly [32](#) [33](#)

C

Calltronic II [42](#)
 Cancelling the lock [14](#)
 Certifications [44](#)
 Check [14](#)
 Check flame sensor [34](#)
 Check overheating sensor [30](#)
 Check the surface sensor [31](#)
 Circuit diagram, control unit [39](#) – [42](#)
 Connector B2 [26](#)
 Connector pin assignment [26](#)
 Connector S1 [26](#)
 Connector sockets [28](#)
 Contents [2](#) [2](#) – [4](#)
 Control and safety devices [8](#)
 “Control box” cover [27](#)
 Control units [15](#)
 Cover, “electric motor” [32](#)
 Current fault [18](#)
 Cutaway view [7](#)

D

Delete fault memory [17](#)
 Diagnosis capable control unit [18](#)
 Diagnosis query [17](#)
 Diesel heater [11](#) [12](#)
 Dismantle glow plug [35](#)
 Dismantling the control box [29](#)
 Dismantling the heater [44](#)
 Disposal [44](#)

E

EasyStart R+ [8](#) [15](#)
 EasyStart R+ radio remote control [8](#) [18](#)
 EasyStart T [15](#)

EasyStart T timer [8](#) [18](#)
 EC Declaration of Conformity [44](#)
 EDiTH Basic [8](#)
 EDiTH Basic diagnosis tool [8](#) [15](#) [16](#)
 Electrical components [14](#)
 Electrics [37](#)
 EMERGENCY OFF [6](#)
 Emergency shutdown [6](#)
 EN ISO 9001:2000 [44](#)
 EN ISO 14001:1996 [44](#)
 Enquire / delete fault memory [18](#)
 Environmental management system [44](#)
 Evaluation [36](#)
 External diagnostics system [15](#)

F

FAME [47](#)
 Fault code display [19](#)
 Fault description [19](#)
 Fault diagnosis [16](#) [18](#)
 Fault memory [18](#)
 Fault memory F1 – F5 [18](#)
 Functional check [6](#)
 Functional description [8](#)
 Function and operation [7](#)

G

Graphite grommet [35](#)
 Guarantee [6](#)

H

Heater circuit diagram [37](#)
 Heater documentation [5](#)
 Heater wiring [37](#)
 Heating at high altitudes [8](#)
 Heating mode [8](#)

I

Initial commissioning [6](#)
 Introduction [5](#)
 ISO/TS 16949:1999 [44](#)

L

Liability claim [6](#)
 Locking the control box [14](#)

7 SERVICE

LIST OF KEY WORDS

M

Measure blower speed [33](#)
 Measurement [36](#)
 Measuring the fuel quantity [36](#)

O

O-ring [28](#)
 Overheating [14](#)
 Overheating sensor [29](#) [30](#)

P

Packaging [44](#)
 Parking heater mode [8](#)
 Parts list [37 – 42](#)
 Petrol heater [10](#)
 Picture symbols [5](#)
 Preparation [36](#)

Q

Quality management [44](#)
 Quantity of fuel [36](#)

R

Radio remote control [8](#)
 Release tool [24](#)
 Remedial action [19](#)
 Remove flame sensor [34](#)
 Repair instructions [24](#)
 Repair steps [26](#)
 Representations [5](#)

S

Safety information [6](#) [24](#) [37](#)
 Safety instructions for installation [6](#)
 Service [44 – 48](#)
 Spare parts list [5](#)
 Special text formats [5](#)
 Special tool [24](#)
 Start attempts [14](#)
 Surface sensor [29](#) [30](#)
 Switching on [8](#)

T

Table of values [30](#) [31](#) [34](#)
 Technical data [9](#)
 Technical description [5](#)

Testing equipment [15](#)

Timer [8](#)
 Toothed ring [28](#)
 Troubleshooting [14](#)

V

Voltage supply [14](#)

W

Water pump [13](#)
 Water pump characteristic curve [13](#)
 What to check first in case of faults [14](#)
 Work on the heater [24](#)

7 SERVICE

LIST OF ABBREVIATIONS

Bioethanol fuel E85

Petrol containing 85 % ethanol.

Bioethanol fuel E100

Fuel made from 100 % bioethanol with < 4 % water content.

FAME

Biodiesel to EN 14214.

ECE regulation

Internationally agreed, uniform technical specifications for vehicles, parts and equipment of motor vehicles.

A

Current intensity in ampere

V

Voltage in volt

W

Power in watt

Headquarters:

J. Eberspächer GmbH & Co. KG

Eberspächerstraße 24

D - 73730 Esslingen

Hotline: 0800 1234300

Fax hotline: 01805 262624

info@eberspaecher.com

www.eberspaecher.com

