

REPAIR INSTRUCTIONS

HYDRONIC S3 ECONOMY 12V CS

HYDRONIC S3 COMMERCIAL 24V CS



These repair instructions are valid for the following engine-independent water heaters:

Heaters for petrol	Order No.
B4E – 12 V CS	20.2007.05.0000
B5E – 12 V CS	20.2008.05.0000
Heaters for diesel	
D4E – 12 V CS	25.2933.05.0000
D5E – 12 V CS	25.2934.05.0000
D6E – 12 V CS	25.2761.05.0000
D5L – 24 V CS	25.2696.05.0000
D6L – 24 V CS	25.2745.05.0000
Heaters for diesel	
with inlet pressure resistant metering pump	
D4E – 12 V CS VDP	25.2943.05.0000
D5E – 12 V CS VDP	25.2942.05.0000

Chapter	Chapter title	Page
	Chapter contents	
1	Introduction	
1.1	Concept of this document	4
1.2	General information	4
1.3	Reference documents	4
1.4	Special text formats and presentations	4
1.4.1	Lists	4
1.4.2	Cross references	4
1.5	Picture symbols	4
1.6	Intended use	5
1.6.1	Range of application of the heater	5
1.6.2	Intended use of the heater (via the vehicle's own heat exchanger)	5
1.7	Non-intended use	5
1.8	Disclaimer	5
1.9	Target groups of this document	5
1.10	Duty to instruct of the target groups	5
1.11	Safety instructions	6
1.12	Warranty and liability	6
1.13	Accident prevention	6
1.14	Functional test following a repair	6
2	Troubleshooting	
2.1	What to check first in case of faults	7
2.2	Control box is locked	7
2.3	Unlocking the control box	7
2.3.1	Overview of testing equipment / control units	7
2.3.2	Fault diagnosis using the control unit	7
2.4	External diagnostics system	7
2.5	Fault code table	8
3	Repair instructions	
3.1	Please note	13
3.2	Special tool	13
3.2.1	Control box dismantling kit	13
3.2.2	Release tool	13
3.3	The repair steps at a glance	14
3.4	Dismantle the heater	14
3.4.1	Repair step 1: Remove the control box	14
3.4.2	Repair step 2: Remove the sensor cover and water connection socket	15
3.4.3	Repair step 3: Remove the heat exchanger	16
3.4.4	Repair step 4: Remove the combustion chamber	16
3.4.5	Repair step 5: Remove the lead harness of the heater	16
3.4.6	Repair step 6: Remove the glow plug	17

3.4.7	Repair step 7: Replace the blower	18
3.4.8	Repair step 8: Remove the blower housing / heat exchanger seal and the fuel connection grommet	18
3.5	Assembling the heater	18
3.5.1	Mount the fuel connection grommet and blower housing / heat exchanger seal	18
3.5.2	Install the glow plug	19
3.5.3	Install the lead harness of the heater / flame sensor	19
3.5.4	Install the combustion chamber	19
3.5.5	Installing the heat exchanger	19
3.5.6	Install the water inlet sensor / water outlet sensor	20
3.5.7	Install water connection socket / sensor cover	20
3.5.8	Mounting the control box	20
3.5.9	Installing the blower cover	21
3.5.10	Measure the fuel quantity	21
3.5.11	Measure fuel quantity with EasyScan	21
3.6	Hydronic S3 Economy component drawing	22
4	Electrics	
4.1	Heater wiring	23
4.2	Parts list for circuit diagram, heater and cable harness	23
4.3	Heater circuit diagrams	24
4.3.1	Heater 12V CS	24
4.3.2	Heater 24V CS	25
4.3.3	Cable harness 12V CS	26
4.3.4	Cable harness 24V CS	27
4.3.5	Cable harness 24V CS ADR	28
4.4	Circuit diagrams for control units	29
4.4.1	Easy Start Pro	29
4.4.2	EasyStart Timer	30
4.4.3	EasyStart Web	31
5	Technical data	
5.1	Petrol heater 12V CS	32
5.2	Diesel heater 12V CS	33
5.3	Diesel heater 24V CS	34
6	Environment	
6.1	Certifications	35
6.2	Disposal	35
6.2.1	Disposal of materials	35
6.2.2	Dismantling the heater	35
6.2.3	Packaging	35
6.3	Technical Support	35
7	Service	
7.1	Standard times	36

1 Introduction

1.1 Concept of this document

This document assists the workshop with troubleshooting and repair of the heater. The document is divided into the following chapters to make it easier to find information quickly.

1 Introduction

Important, introductory information about use and the structure of this document

2 Troubleshooting

Information about unlocking the control box and the fault codes of the heater, their meaning and troubleshooting measures / remedies based on a clear table

3 Repair instructions

Information about special tools, dismantling and assembly of the heater's components as well as a component drawings

4 Electrics

Information on the electronics, circuit diagrams and components

5 Technical data

Technical data of the petrol and diesel heaters

6 Environment

Information about certification and disposal

7 Service

Information about setup times and technical support

1.2 General information

This document is used to correct faults and to carry out repairs for the heaters listed on the title page, and is valid to the exclusion of all liability claims. The necessary work may only be carried out by appropriately trained personnel of an Eberspächer service partner.

Depending on the version or revision status of the heater, differences may occur compared to this documentation. Please check this before carrying out the repair and take any possible differences into account.

1.3 Reference documents

Technical description

Describes the function and proper installation and contains all information necessary for safe operation of the heater.

Spare parts list

Contains the information necessary for ordering spare parts.

Installation recommendation

Describes vehicle-specific installation situations.

Installation Instructions Plus

Supplementary information on heaters and control units.

1.4 Special text formats and presentations

Special text formats and picture symbols are used in this document to emphasise different situations and subjects. Please refer to the following examples for their meanings and appropriate action.

1.4.1 Lists

- This dot (▪) indicates a list or action step, introduced by a heading.
 - If an indented dash (–) follows a “dot”, this list/action step is a sub-section/secondary step of the black dot.

1.4.2 Cross references

Underlined blue text denotes a cross-reference, which can be clicked in the PDF format. The part of the document named in the text is then displayed.

1.5 Picture symbols

Regulation!

This information indicates a statutory regulation. Any violation of these regulations results in expiry of the type-approval for the heater and exclusion of any guarantee and liability claims against Eberspächer Climate Control Systems GmbH & Co. KG.

Danger!

“Danger” indicates a situation that can directly result in death or serious injuries if not avoided.

- This arrow indicates the appropriate measures to avert the imminent danger.

Warning!

“Warning” indicates a situation that can potentially result in death or serious injuries if not avoided.

- This arrow indicates the appropriate measures to avert the potential danger.

Caution!

“Caution” indicates a situation that can potentially result in minor or slight injuries if not avoided.

- This arrow indicates the appropriate measures to avert the potential danger.

Note

This note contains recommendations for use and useful tips for the operation, installation and repair of the product.

1.6 Intended use

1.6.1 Range of application of the heater

The water heater operating independently of an engine is intended for installation in the following vehicles:

- All kinds of vehicles
- Construction machinery
- Agricultural machinery

1.6.2 Intended use of the heater (via the vehicle's own heat exchanger)

- Pre-heating, de-misting windows
- Heating and keeping the following warm:
 - Driver and working cabs
 - Freight compartments
 - Passenger and crew compartments
 - Vehicle engines and units

Note

- Use with a 230 V connection to the public power system (e.g. houseboats and camper vans) only with the “CE application” installation kit.
- Only use and operate the heater within the scope of the intended use stated by the manufacturer and in compliance with the documentation enclosed with each heater.

1.7 Non-intended use

On account of its functional purpose, the heater is not approved for the following applications:

- Long-term continuous operation, e.g. for heating:
 - Residential rooms
 - Garages
 - Work huts, weekend homes and hunting lodges
 - Houseboats, etc.

Caution!

Use, operation and deployment of the product outside the intended use stated by the manufacturer can cause considerable injuries to people and/or damage to machinery and property.

→ Only use the product for the stipulated purpose and in the approved area of use.

1.8 Disclaimer

The manufacturer is not liable for damage caused by improper use or incorrect operation. Failure to comply with the safety instructions makes the guarantee null and void and this leads to the exclusion of any liability of Eberspächer Climate Control Systems GmbH & Co. KG.

1.9 Target groups of this document

This document is aimed at the following target groups:

Service company

The “service company” target group includes all service companies trained by Eberspächer that purchase heaters and air-conditioners and their control units, accessories and spare parts from Eberspächer or the trade and install, repair or service these on behalf of an end user.

Installation company

The “installation company” target group includes all companies trained by Eberspächer that purchase heaters and air-conditioners and their control units, accessories and spare parts from Eberspächer and install, repair or service these on behalf of another company (usually the automotive / body manufacturer).

End user

The “end user” target group includes all natural persons who operate a heater or air conditioner with the help of a control unit, regardless of whether they act as a consumer or as part of their job.

1.10 Duty to instruct of the target groups

Each named target group must fulfil their duty to instruct in full. The duty to instruct relates to the passing on of technical documents.

Technical documents are all documents published by Eberspächer for the installation, operation, use, maintenance or repair of heaters and air conditioners and their control units, accessories and spare parts.

Note

- If not explicitly defined in the following, the technical documents can be passed on printed out as hard copies, on a data carrier or by internet download.
- Current technical documents can be downloaded from the Eberspächer website.

Responsibility of the installation company

The installation company must pass on the following technical documents to the company that employs them, and it in turn is obliged to pass on the documents to the end user:

- Technical description
- Operating instructions

Responsibility of the service company

The service company must pass on the following technical documents to the end user, even if they employ a subcontractor:

- Technical description
- Operating instructions

Note

The named target groups must ensure that the operating instructions produced by the manufacturer for the product are made available to the end user in printed form and in their own national language. If necessary this can be a short form of the detailed operating instructions, which are additionally enclosed with the product on a data

carrier or are available to download from the internet.

1.11 Safety instructions



Danger!

Fire hazard. Risk of poisoning due to exhaust gases.

Improper repair or installation can result in toxic exhaust gases getting into the interior of the vehicle or a fire.

- Repair and installation of the heater by authorised and trained skilled personnel only.
- Use original spare parts only.
- Comply with the official regulations.
- Take into account and follow this document and all applicable documentation.



Note

- Have the heater installed only by a service partner authorised by the manufacturer according to the instructions in this manual, possibly according to special installation recommendations; the same applies to any repairs to be carried out in the case of repairs or guarantee claims.
- Repairs by third-parties not authorised by the manufacturer and / or with non-original spare parts are dangerous and therefore not allowed. They result in expiry of the type-approval of the heater; and thus, when installed in motor vehicles, they can cause expiry of the vehicle's operating licence.
- The following measures are not allowed:
 - Changes to heating-relevant components.
 - Use of third party parts not approved by the manufacturer.
 - Installation or operation deviating from the statutory regulations, safety instructions or specifications relevant to safe operation as stated in the installation instructions and operating instructions. This applies in particular to the electrical wiring, fuel supply, combustion air system and exhaust system.
- Only use original accessories and original spare parts for installation and repairs.
- Only use the control units approved by the manufacturer to operate the heater. Use of other control units can cause malfunctions.
- Before the heater is installed again in another vehicle, rinse the heater parts carrying water with clear water.
- When carrying out electric welding on the vehicle, disconnect the positive cable at the battery and attach it to ground to protect the control box.
- Use only anti-freeze products approved by the vehicle manufacturer to top-up; please refer to the vehicle's operating manual. Blending with unapproved anti-freeze can cause damage to the engine and heater.
- Defective fuses may only be replaced by fuses with the specified fuse rating.

1.12 Warranty and liability

Eberspächer Climate Control Systems GmbH & Co. KG does not accept any liability whatsoever for defects and damage, which are due to installation or repair by unauthorised and untrained persons.

Compliance with official regulations and the safety instructions is prerequisite for liability claims. Failure to comply with official regulations and safety instructions leads to exclusion of any liability of the manufacturer.

1.13 Accident prevention

Always follow all accident prevention regulations and shop and operating safety instructions.

1.14 Functional test following a repair

- Vent the coolant circuit and the whole fuel supply system. Comply with the instructions issued by the vehicle manufacturer.
- Open all heating circuits before the trial run (set the temperature control to "warm").
- Switch on the heater at the control unit and during the trial run check all water and fuel connections for leaks and tight fit.
- Correct any faults during operation with the help of diagnostic equipment or the control unit.



Note

The function of the heater is described in detail in the "Technical Description" document.

Emergency shutdown – EMERGENCY OFF

In an emergency carry out an emergency shutdown as follows:

- Switch off the heater via the control unit or disconnect it from the power supply (remove fuse / disconnect battery).

2 Troubleshooting

2.1 What to check first in case of faults

- Check
 - Fuel in the tank?
 - Fuel lines filled? (Visual check)
 - In the case of a diesel heater: summer diesel still in the fuel lines?
 - Heater controller (water valve) fully set to “warm”?
 - Combustion air system or exhaust system damaged or blocked?
- Electrical components
 - Cables, connections damaged?
 - Contacts corroded?
 - Fuses defective?
 - Faulty wiring (short circuit, interruption)?
- Check battery voltage
 - Undervoltage protection ON (battery voltage < 10.5 V)?
 - Overvoltage protection ON (battery voltage > 16 V)?
- Check voltage supply UBatt (Terminal 30)
 - Unplug the 2-pin connector -XB1 from the heater.
 - Measure the voltage between cable RD (chamber 1) and cable BN (chamber 2) in the 2-pin connector -XB1.

In case of a voltage deviation, check the following components for corrosion or interruption:

 - Fuses
 - Supply lines
 - Earth connections
 - Battery terminal posts

2.2 Control box is locked

The control box is locked if the following faults occur:

- Unsuccessful start attempts
 - After 3 consecutive failed start attempts in succession, see [Fault code P00012B](#).
- Overheating
 - After three overheating cutouts, see [Fault code P00011A](#).

2.3 Unlocking the control box

The control box can be unlocked with testing equipment / a control unit. For the procedure and description for testing equipment and for control units see “Installation Instructions Plus – EasyStart/Altitude Kit, Special Functions and Diagnosis”.

2.3.1 Overview of testing equipment / control units

- The electronic control box can store up to 10 faults.
- The current faults and the stored faults can be read out, displayed and deleted.

Unlocking the control box, reading out, displaying and deleting the fault memory is possible using the following testing equipment / control units:

Test equipment	Order No.
EasyScan diagnostic tool	22.1550.89.0000

Control unit	Order No.
▪ EasyStart Pro	22.1000.35.2200
▪ EasyStart Web	22.1000.34.7800

2.3.2 Fault diagnosis using the CAN control unit

- After activating the control unit, faults are displayed.
- The current faults and the stored faults can be read out, displayed and deleted by using the workshop menu.

The fault diagnosis with control units is described in detail in the reference document “Installation Instructions for Plus – EasyStart/Altitude Kit, Special Functions and Diagnosis”.

Note

- For further information and up-to-date circuit diagrams of the control units, see “Installation Instructions Plus” in the Eberspächer Partner Portal.
- Not only the defective component, but also a defective current circuit results in a fault or error message.
- Fault codes, fault descriptions, causes / remedial actions are described [from page 8](#).
- Ensure adequate battery voltage (> 10.5 V).



2.4 Vehicle-specific diagnostic system

If an external diagnostics system is to be used, contact the vehicle manufacturer.

2.5 Fault code table

Fault code P000...	Error description	Cause
P000100 P000101 P000102	Water outlet sensor <ul style="list-style-type: none"> – Interruption – Short circuit – Short circuit after Ub+ 	<ul style="list-style-type: none"> ▪ Remedial action ▪ Check the water outlet sensor. <ul style="list-style-type: none"> – Check cables for continuity, short circuit and damage. – Unplug connector XB4, measure resistance between cable RD (chamber 9) and cable RD (chamber 10). – Measured values see page 17, deviating values → renew lead harness of heater.
P00010A	Cold air – timeout	The combustion chamber has not cooled sufficiently for a restart. <ul style="list-style-type: none"> ▪ Check whether hot combustion air is drawn in. If not → check flame sensor, see Fault code P000120 and Fault code P000121.
P000110 P000111 P000112	Water inlet sensor <ul style="list-style-type: none"> – Interruption – Short circuit – Short circuit after Ub+ <p>i Note! Fault code P000110 and P000111 are only displayed if</p> <ul style="list-style-type: none"> ▪ the heater is in operation ▪ Temperature reached at water outlet sensor at least 80 °C. 	<ul style="list-style-type: none"> ▪ Check the water inlet sensor. <ul style="list-style-type: none"> – Check cables for continuity, short circuit and damage. – Unplug connector XB4, measure resistance between cable BU (chamber 5) and cable BU (chamber 6). – Measured values see page 17, deviating values → renew lead harness of heater.
P000114	Possible risk of overheating (implausible signal) <p>i Note! Fault code P000114 is only displayed if</p> <ul style="list-style-type: none"> ▪ the heater is in operation ▪ Temperature reached at water outlet sensor at least 80 °C. 	Too large temperature difference between the water inlet and water outlet sensor. <ul style="list-style-type: none"> ▪ For remedial action, see Fault code P000115. ▪ Check the water inlet sensor. <ul style="list-style-type: none"> – Unplug connector XB4, measure resistance between cable BU (chamber 5) and cable BU (chamber 6). – Measured values see page 17, deviating values → renew lead harness of heater.
P000115	Overheating – software threshold exceeded	Temperature at the water outlet sensor >125 °C. <ul style="list-style-type: none"> ▪ Check water circuit for leaks (heater controller in warm position) ▪ If non-return valve / thermostat in the water circuit, check the flow direction. ▪ Check water throughput rate. ▪ Vent water circuit. ▪ Check the water outlet sensor <ul style="list-style-type: none"> – Check cables for continuity, short circuit and damage. – Unplug connector XB4, measure resistance between cable RD (chamber 9) and cable RD (chamber 10). – Measured values see page 17, deviating values → renew lead harness of heater. ▪ Check water pump, see Fault code P000253 to Fault code P000258.

Fault code P000...	Error description	Cause <ul style="list-style-type: none"> ▪ Remedial action
P000116	Overheating – hardware threshold exceeded	Temperature at the water outlet sensor >130 °C. <ul style="list-style-type: none"> ▪ For remedial action, see Fault code P000115. ▪ Check the water outlet sensor. <ul style="list-style-type: none"> – Check cables for continuity, short circuit and damage. – Unplug connector XB4, measure resistance between cable RD (chamber 9) and cable RD (chamber 10). <ul style="list-style-type: none"> – Measured values see page 17, deviating values → renew lead harness of heater.
P00011A	Operating lock-out – too many overheating events detected	The control box is locked due to too frequent consecutive overheating (Fault code P000114 , Fault code P000115). <ul style="list-style-type: none"> ▪ For remedial action, see Fault code P000114, Fault code P000115. ▪ Unlock control box, see page 7.
P000120 P000121 P000122	Flame sensor <ul style="list-style-type: none"> – Interruption – Short circuit – Short-circuit to Ub+ 	<ul style="list-style-type: none"> ▪ Check flame sensor. <ul style="list-style-type: none"> – Check cable for continuity, short circuit and damage. – Unplug connector XB4, measure resistance between cable BN (chamber 7) and cable BN (chamber 8). <ul style="list-style-type: none"> – Measured values see page 17, deviating values → renew lead harness of heater. ▪ Next display Fault code P000120, Fault code P000121 → Renew control box, see repair step 1, see page 14.
P000125 P000126 P000127 P000128 P000129	Flame cutout from start process Flame cutout within the control range 0% – 25% Flame cutout within the control range 25% – 50% Flame cutout within the control range 50% – 75% Flame cutout within the control range 75% – 100% <p>i Note! In case of flame cutout during the start phase or in normal operation the heater is restarted (max. 3 times). If the restart was successful, the fault code display is deleted.</p>	<ul style="list-style-type: none"> ▪ Check exhaust and combustion air system. ▪ Check fuel quantity and fuel supply, see page 21. ▪ Check flame sensor, see Fault code P000120 and Fault code P000121.
P00012A	Safety time – exceeded	<ul style="list-style-type: none"> ▪ Check exhaust and combustion air system. ▪ Check fuel quantity and fuel supply, see page 21. ▪ Renew the fuel filter. ▪ Clean the fuel filter in the connection socket of the metering pump.
P00012B	Operating lock-out, too many safety timeouts	Following three unsuccessful start attempts the control box is locked. <ul style="list-style-type: none"> ▪ Unlock control box, see page 7. ▪ Check fuel quantity and fuel supply, see page 21.
P000143	Air pressure sensor – implausible signal	Heater in emergency mode. The air pressure is outside the characteristic curve for the altitude adjustment (P < 598 hPa or P > 1106 hPa). <ul style="list-style-type: none"> ▪ 12V: Check connection to the CAN BE. Delete error. ▪ 24V: Delete error. If the fault persists, replace the control box
P000200 P000201	Metering pump interruption Metering pump – short circuit	<ul style="list-style-type: none"> ▪ Check metering pump lead harness for continuity, short circuit and damage. <ul style="list-style-type: none"> – Lead harness ok → renew the metering pump.

Fault code P000...	Error description	Cause
P000202	Metering pump – short circuit downstream of +Ub or transistor error	<ul style="list-style-type: none"> ▪ Remedial action ▪ Check cables for continuity, short circuit and damage. <ul style="list-style-type: none"> – Unplug the connector at the metering pump. ▪ Display Fault code P000200 metering pump defective → renew metering pump.
P0002a1	Water pump – Control / Diagnosis pin interruption	<ul style="list-style-type: none"> ▪ Check lead harness of the water pump: <ul style="list-style-type: none"> – Unplug connector -XB3 at the heater – Unplug connector -XB8/2 at the water pump – Check water pump lead harness for continuity, short circuit and damage – If water pump lead harness ok → renew the water pump
P000210 P000211 P000212	Glow plug – interruption Glow plug – short circuit Glow plug – short circuit downstream of +Ub or transistor error  Caution! Damage to unit in case of overvoltage Voltage > 9.5 V irreparably damages the glow plug. → Test function with max. 9.5 V.	<ul style="list-style-type: none"> ▪ Check glow plug. <ul style="list-style-type: none"> – Check cables for continuity, short circuit and damage. – Unplug connector -XB4, unclip cable WH (chamber 3) and cable WH (chamber 4). – Apply 9.5 V ±0.1 V voltage to the glow plug and after 25 sec measure the current intensity. <ul style="list-style-type: none"> – Measured value 9.5 A (+1 / -1.5) the glow plug is ok – Deviating values → renew the glow plug.
	 Note Note the short-circuit withstand capability of the power pack.	
P000213	Glow plug – ignition energy too low	Glow plug energy input is too low. <ul style="list-style-type: none"> ▪ Check cables for continuity, short circuit and damage. ▪ Check glow plug, see Fault code P000210 to Fault code P000212.
P000220 P000221 P000222	Electric motor – interruption Electric motor – short circuit Electric motor – short circuit downstream of +Ub or transistor error	<ul style="list-style-type: none"> ▪ Measure blower speed with EasyScan diagnostic tool, see EasyScan operating instructions.
P000223 P000224	Electric motor – blocking Electric motor – current input too low	Impeller blocked (frozen, soiled, sluggish, ...). <ul style="list-style-type: none"> ▪ Remove blockage. <ul style="list-style-type: none"> – Check electric motor for smooth and easy running by turning the impeller manually. ▪ Next display Fault code P000223 / Fault code P000224 → renew the blower, see repair step 7, Page 18.
P000250 P000251	Water pump – interruption Water pump – short circuit	<ul style="list-style-type: none"> ▪ Check lead harness of the water pump: <ul style="list-style-type: none"> – Unplug connector -XB3 at the heater – Unplug connector -XB8/2 at the water pump. – Check cable for continuity, short circuit and damage. <ul style="list-style-type: none"> – Lead harness of the water pump ok → renew the water pump.
P000252	Water pump - short circuit downstream of +Ub or transistor error	<ul style="list-style-type: none"> ▪ Unplug connector -XB8/2 at the water pump. <ul style="list-style-type: none"> – Display Fault code P000250 Water pump defective → renew water pump.
P000253	Water pump – blocking	<ul style="list-style-type: none"> ▪ Water hoses laid free from kinks?
P000254	Water pump – overcurrent cutout	<ul style="list-style-type: none"> ▪ Water pump / water circuit dirty?

Fault code P000...	Error description	Cause <ul style="list-style-type: none"> ▪ Remedial action
P000255	Water pump – speed below minimum	<ul style="list-style-type: none"> ▪ Water pump / water circuit dirty?
P000256	Water pump – dry running	<ul style="list-style-type: none"> ▪ Check the coolant liquid level in the water circuit. ▪ Vent the water pump / water circuit.
P000257	Water pump – overheating	Water pump ambient temperature too high. <ul style="list-style-type: none"> ▪ Position the water pump at an adequate distance from hot vehicle parts.
P000258	ADR water pump – Undervoltage / Overvoltage	<ul style="list-style-type: none"> ▪ Check lead harness of the water pump: <ul style="list-style-type: none"> – Unplug connector -XB3 at the heater – Unplug connector -XB8/2 at the water pump. – Check cable for continuity, short circuit and damage. <ul style="list-style-type: none"> – Lead harness of the water pump ok -> renew the water pump.
P000259	ADR water pump / vehicle blower – Short circuit	<ul style="list-style-type: none"> ▪ Check the cables to the water pump and to the vehicle blower for continuity, short circuit and damage. ▪ Check the coolant circuit. ▪ Check blower relay.
P000260	Universal output Interruption	<ul style="list-style-type: none"> ▪ Check cable for continuity and damage. ▪ If necessary, check coding for universal outlet.
P000261	Vehicle blower – short circuit	<ul style="list-style-type: none"> ▪ Check electric motor cover for damage and correct fit. <ul style="list-style-type: none"> – Electric motor cover ok -> renew blower relay -K1.
P000262	Universal output Short circuit downstream of Ub+ or transistor fault	<ul style="list-style-type: none"> ▪ Check cable for continuity, short circuit and damage.
P000300	Overheating detection Metering pump hardware or cutout circuit defective	<ul style="list-style-type: none"> ▪ Check the water outlet sensor. <ul style="list-style-type: none"> – Check cables for continuity, short circuit and damage. – Unplug connector XB4, measure resistance between cable RD (chamber 9) and cable RD (chamber 10). <ul style="list-style-type: none"> – Measured values see page 17, deviating values -> renew lead harness of heater. ▪ Next display Fault code P000300 -> renew lead harness of the heater. ▪ Unlock control box, see page 7.
P000301	Control box defective	<ul style="list-style-type: none"> ▪ Replace control box, see repair step 1, Page 14
P000302	Control box defective	
P000303	Control box defective	<ul style="list-style-type: none"> ▪ Replace control box, see repair step 1, Page 14
P000304	Control box defective	<ul style="list-style-type: none"> ▪ Replace control box, see repair step 1, Page 14
P000305	Control box defective	<ul style="list-style-type: none"> ▪ Replace control box, see repair step 1, Page 14
P000306	Control box defective	<ul style="list-style-type: none"> ▪ Replace control box, see repair step 1, Page 14
P000307	CAN communication error control unit	<ul style="list-style-type: none"> ▪ Delete error, if it occurs repeatedly check the CAN connection between heater and control unit
P00030A	CAN communication error	<ul style="list-style-type: none"> ▪ Delete error, if it occurs repeatedly check the CAN connection between heater and control unit
P000310	Control box cutout due to overvoltage	Overvoltage applied at the control box without interruption for at least 20 seconds. <ul style="list-style-type: none"> ▪ Unplug connector -XB1 at the heater.
P000311	Heater cutout due to overvoltage  Note! Heater is not functioning.	<ul style="list-style-type: none"> ▪ Start the vehicle engine. ▪ Measure voltage between cable RD (chamber 1) and cable BN (chamber 2). <ul style="list-style-type: none"> – Voltage >15 volt – Check alternator controller – Check the battery.

Fault code P000...	Error description	Cause
P000312	Control box cutout due to undervoltage	Undervoltage applied at the control box without interruption for at least 20 seconds.
P000313	Heater cutout due to undervoltage  Note! Heater is not functioning.	<ul style="list-style-type: none"> ▪ Remedial action ▪ Unplug connector -XB1 at the heater. ▪ Start the vehicle engine. ▪ Measure voltage between cable RD (chamber 1) and cable BN (chamber 2). <ul style="list-style-type: none"> – Voltage < 10 volt – Check the fuses, the supply cables, the ground connections and the positive terminal post at the battery for voltage drop (corrosion).
P000315	Implausible air pressure information	<ul style="list-style-type: none"> ▪ Check connection to the control unit. If fault persists, use EasyScan to test the control unit.
P000316	Insufficient heat dissipation via the coolant	<ul style="list-style-type: none"> ▪ Too many consecutive short heating mode operations. ▪ Check coolant circuit
P000330	Control box defective	<ul style="list-style-type: none"> ▪ Replace control box, see repair step 1, Page 14
P000331	Control box defective	<ul style="list-style-type: none"> ▪ Replace control box, see repair step 1, Page 14
P000332	Control box defective	<ul style="list-style-type: none"> ▪ Replace control box, see repair step 1, Page 14
P000342	Invalid configuration	<ul style="list-style-type: none"> ▪ 12V / 24V: Too many CAN components connected. Check the configuration. ▪ 24V ADR: Use one CAN control unit only, check the connection to the control unit if necessary.
P000394	ADR button – Short circuit	<ul style="list-style-type: none"> ▪ Check the cable and button for continuity, short circuit, damage. Replace if necessary.
P000500	Fault memory entry ErrorState_GSC. Fault response: Heating or ventilation mode is continued.	<ul style="list-style-type: none"> ▪ Withdrawal of the active request (fault remains active as long as heating or diagnosis request still exists). ▪ Delete fault memory.
P000A00	Communication is ended by the heater. EasyFan does not respond to the coded number of messages.	<ul style="list-style-type: none"> ▪ Reset the fault by withdrawing the active request (fault remains active as long as heating or diagnosis request exists). ▪ Delete fault memory.
P000E01	Runtime limit exceeded	<ul style="list-style-type: none"> ▪ Coded runtime end reached.

3 Repair instructions

3.1 Please note

This chapter describes the permitted repair work on the heater.

i Note!

- The heater must be removed from the vehicle for the repair work to be carried out.
- After completing all the work and installing the heater in the vehicle, perform a functional test of the heater, [see page 6](#).
- Assembly of the heater is described [from page 18](#).

! Danger!

Risk of injury, burns and poisoning!

Ensure the following before carrying out any work on the heater:

- Switch off the heater and leave it to cool.
- Disconnect the battery.
- Do not operate the heater in enclosed spaces (garage / workshop). Exception: use of an exhaust extractor.

! Caution!

Possible unit damage

- Always renew the seals and O-rings of dismantled components.
- Check all components for damage and replace if necessary.
- Check plug-in contacts, plug-in connections and cables for corrosion and damage, and repair if necessary.
- Use original spare parts only.
- After working on the coolant circuit, check the coolant level and if necessary top up according to the vehicle manufacturer's instructions.
- Then vent the coolant circuit.
- Operation and after running of the heater may only be stopped in an emergency (see "EMERGENCY OFF" [on page 20](#)) by interrupting the battery current (risk of heater overheating).

i Note!

Thread-forming screws are used to fix the components in the factory. In case of repair the thread is already pre-cut by the initial installation.

Installation instructions

- Position screw by hand and screw in.
- Always keep to the given tightening torque.
- When screwing for the second time also position by hand and do not cut a new thread.
- The thread-forming screw is suitable for max. 6 installation attempts.

3.2 Special tool

3.2.1 Control box dismantling kit

Eberspächer Order No. 25.2652.81.0000

The dismantling kit is required to unlock the control box and consists of a lever (1) with two release wedges (2). To use the wedges, break them off at the connection pins.

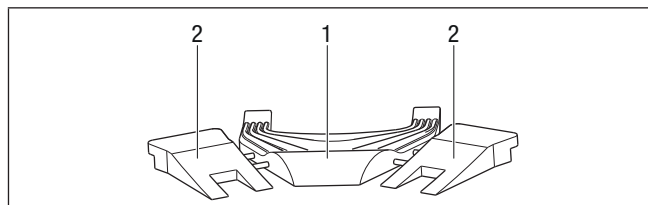

3.2.2 Release tool

The release tool is used to release contacts in the connectors. The tool can be ordered directly from the manufacturer HERTH+BUSS ELPARTS.

- for tab connector 1.2 mm Order No. 959.45.400
- for tab connector / tab receptacle 2.8 mm Order No. 959.45.402

3.3 The repair steps at a glance

Note!

These repair instructions describe how to dismantle the heater in individual repair steps. Reference is made to the necessary preceding steps to be carried out at the relevant repair steps.

Repair step 1

Remove the control box [Page 14](#)

Renew electric motor cover [Page 15](#)

Repair step 2

Remove sensor cover / water connection socket [Page 15](#)

Repair step 3

Remove the heat exchanger [Page 15](#)

Repair step 4

Remove the combustion chamber [Page 16](#)

Repair step 5

Remove lead harness of the heater [Page 16](#)

Check the flame sensor [Page 17](#)

Check the water inlet sensor [Page 17](#)

Check the water outlet sensor [Page 17](#)

Repair step 6

Dismantle glow plug [Page 17](#)

Check glow plug [Page 17](#)

Repair step 7

Replace the blower housing [Page 18](#)

Repair step 8

Remove the blower housing / heat exchanger seal and fuel connection grommet [Page 18](#)

3.4 Dismantle the heater

Caution!

Unit damage due to unbalance!

The impeller is pressed on precisely. If the heater is put down on the blower it can cause damage to the blower.

→ Do not lay heater on its impeller.

→ Always put down heater to the side.

3.4.1 Repair step 1: Remove the control box

Note!

Use the dismantling kit to remove the control box. Do not undo the bottom snap connections on the control box.

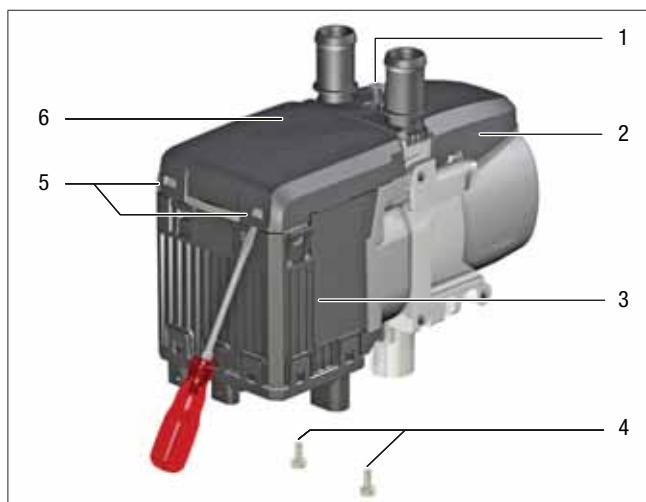

- Undo both screws (4) from the control box (3).
- Undo the screw (1) of the sensor cover (2) by 3 turns and lift up the sensor cover (2).
- Release both snap connections (5) on the blower cover (6).
- Lift up the blower cover (6).

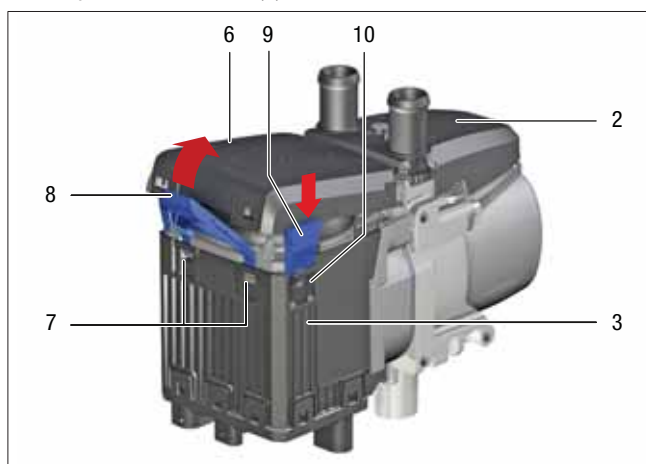

- Insert both wedges (9) between the blower cover (6) and the snap catches (10) of the control box (3), release the snap catches.
- Insert the lever (8) in the snap catches (7) of the control box (3) and unlock the control box. To do this press the lever (8) up to the blower cover (6).

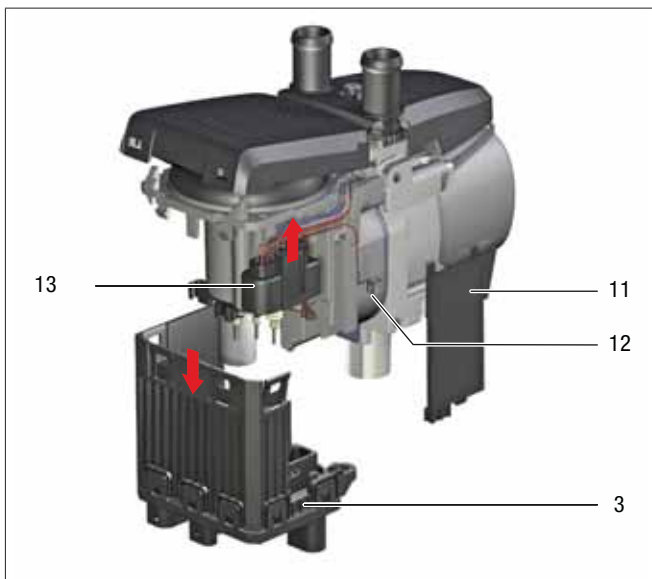

- Pull off the control box (3) carefully, at the same time remove the electric motor cover (11) and the ground cable (12).
- Unlock and unplug connector -XB4 (13).

Renew the electric motor cover

⚠ Caution!

Damage to the unit caused by leak or dirt

The seals on the electric motor cover are permanently deformed following removal of the control box. An integral seal with the control box is not ensured on re-installation.

- Always replace the electric motor cover.
- If the electric motor cover is renewed, dirt particles and metal parts can get inside the motor.
- Install the new electric motor cover immediately.
- For installation details, see point 12 onwards.

The electric motor cover is included in the

- Kit – control box
- Kit – glow plug
- Kit – heater lead harness.

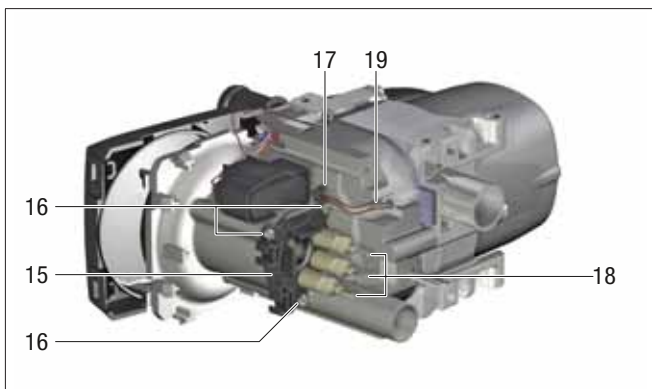

- Unhook the flame sensor (19) connection cables at the guide hook (17).
- Undo three screws (16) from the electric motor cover (15).

- Pull the electric motor cover (15) carefully off the connection pins (18).

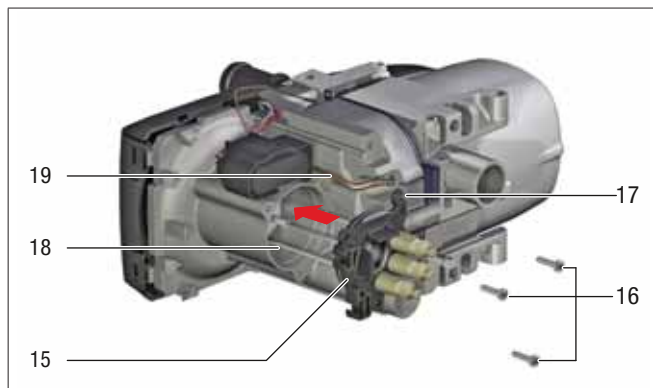

- Push the new electric motor cover (15) carefully onto the connection pins (18) and press on lightly.

i Note!

Do not change the position of the connection pins.

- Screw in the 3 screws M3 × 12 (16). Tightening torque 1.5±0.1 Nm.
- Hook the flame sensor (19) connection cables into the guide hook (17).

i Note!

Mount the control box, [see page 20](#).

3.4.2 Repair step 2: Remove the sensor cover and water connection socket

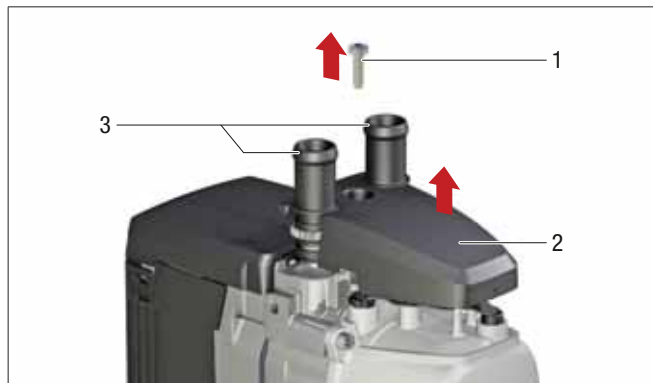

- Undo the screw (1).
- Remove the sensor cover (2) and water connection socket (3).

i Note!

Mount the sensor cover and water connection socket, [see page 20](#).

3.4.3 Repair step 3: Remove the heat exchanger

- Carry out repair step 1, [Page 14](#) and repair step 2, [Page 15](#) first.

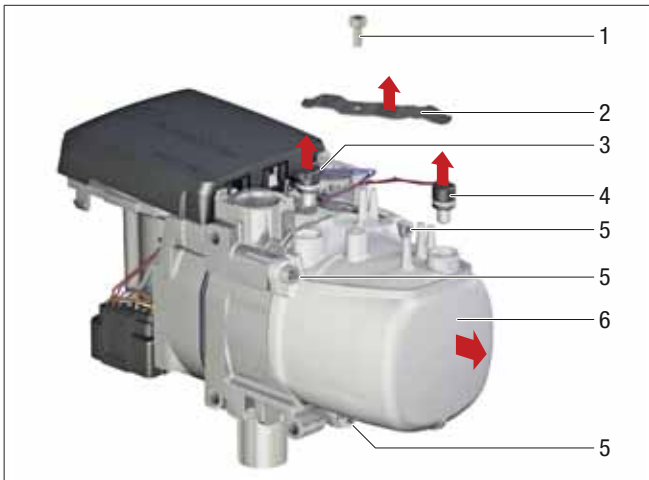

- Undo the screw (1), remove the compression spring (2).
- Use pliers to pull out the water inlet sensor (3) and water outlet sensor (4).
- Undo the screws (5), pull off the heat exchanger (6).

i Note!

- Install the heat exchanger, [see page 19](#).
- Repair step 1 is not necessary if the heat exchanger is replaced

3.4.4 Repair step 4: Remove the combustion chamber

- Firstly, carry out repair step 1, [Page 14](#) up to repair step 3, [Page 16](#).

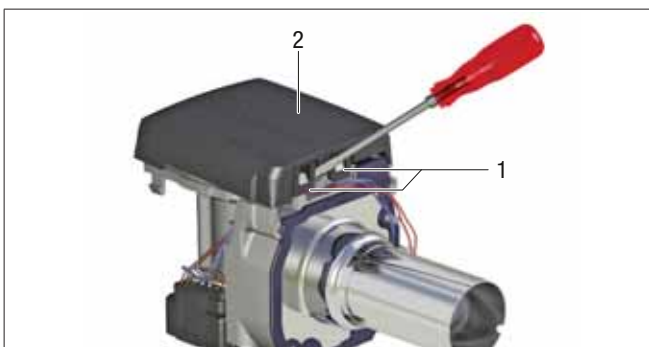

- Unlock the snap connections (1) on the blower cover (2) and remove the blower cover.



- Pull the combustion chamber (3) together with the glow plug off the blower housing.



- Pull out the glow plug (4).

i Note!

Install the combustion chamber, [see page 19](#).

3.4.5 Repair step 5: Remove the lead harness of the heater

i Note!

- If the lead harness of the heater (4) is renewed, unplug the glow plug connection cables from the connector -XB4 (Chamber 3 and 4), see Repair step 6, [Page 17](#).
- Apart from the flame sensor (3), the other components on the lead harness of the heater (4) (ground cable (5), water inlet sensor (2) and water outlet sensor (1)) have already been removed from the heater.

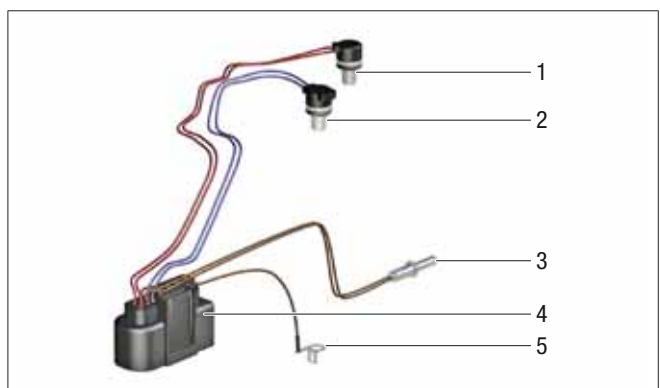

- Carry out [Page 14](#) to [Page 16](#) first.

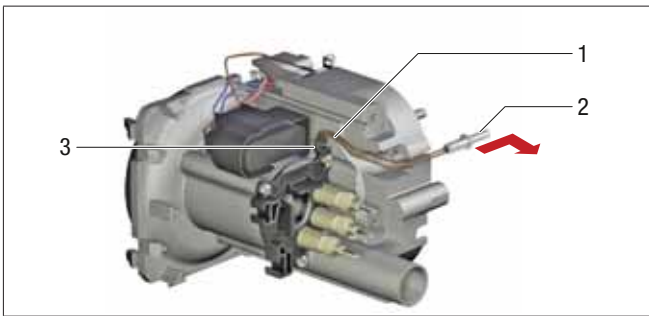

- Unhook the flame sensor connection cables (1) from the guide hook (3) on the electric motor.
- Remove the flame sensor (2) on the blower housing.

Check flame sensor

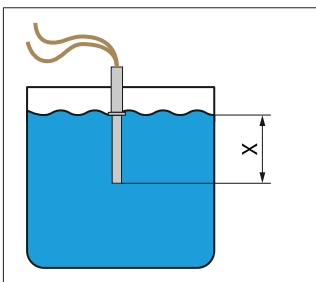

The sensor test is performed in liquid at temperatures up to max. 200 °C.

Sensor insertion depth
X = 15 mm

Use a multimeter to measure the resistance in connector -XB4 between cable BN (chamber 7) and cable BN (chamber 8). If the value lies outside the values table, replace the lead harness of the heater.

Table of values

θ [°C]	R [Ω]	θ [°C]	R [Ω]
-50	830 ±11	50	1194 ±12
0	1000 ±10	100	1385 ±15
20	1078 ±11	150	1573 ±20
25	1097 ±11	200	1758 ±24

Note!

Install the lead harness, [see page 19](#).

Check the water inlet and outlet sensor

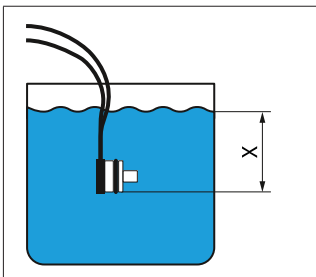

The sensor test is performed in liquid at temperatures up to max. 200 °C.

Sensor insertion depth
X = 50 mm ±5 mm

- Check the water inlet sensor
Use a multimeter to measure the resistance in connector -XB4 between cable BU (chamber 5) and cable BU (chamber 6). If the value lies outside the values table, replace the lead harness of the heater.
- Check the water outlet sensor
Use a multimeter to measure the resistance in connector -XB4 between cable RD (chamber 9) and cable RD (chamber 10). If the value lies outside the values table, replace the lead harness of the heater.

Table of values

θ [°C]	R [kΩ]	θ [°C]	R [kΩ]
-50	657 ±80 kΩ	80	1.26 ±100 Ω
-40	330.6 ±33 kΩ	100	0.677 ±60 Ω
-20	96.3 ±8 kΩ	120	0.389 ±38 Ω
0	32.55 ±500 Ω	150	0.183 ±20 Ω
25	10* ±11 Ω	180	0.095 ±12 Ω
40	5.33 ±320 Ω	200	0.064 ±0 Ω
60	2.49 ±175 Ω		

Note!

Install the lead harness, [see page 19](#).

3.4.6 Repair step 6: Remove the glow plug

- Firstly, carry out repair step 1, [Page 14](#) up to repair step 5, [Page 16](#).

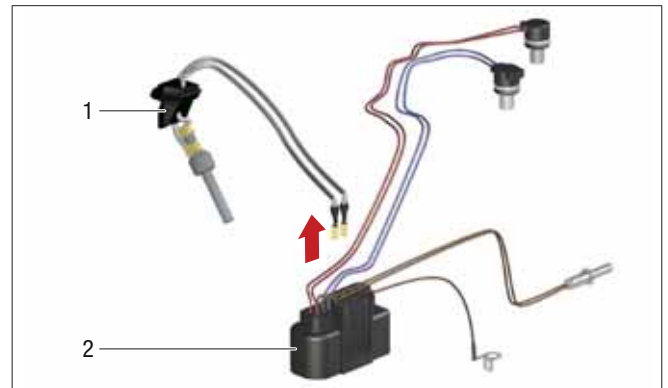

- Unplug the WH connection cables from the glow plug (1) at the connector -XB4 (2) (chamber 3 and 4).

Check glow plug

Danger!

Risk of burns and fire due to glowing component.

After the operating voltage is applied the glow plug becomes very hot and can cause burns.

→ Insert glow plug in combustion chamber or jig.

- Apply 9.5±0.1 volt voltage to the glow plug
- After 25 sec. measure the current intensity and then disconnect from the power supply.
 - Measured value 9.5 A (+1 / -1.5) the glow plug is ok
 - Deviating values → renew the glow plug.

Note!

Install the glow plug, [see page 19](#).

3.4.7 Repair step 7: Replace the blower

- Firstly, carry out repair step 1, [Page 14](#) up to repair step 5, [Page 16](#).
- Then replace the blower.

3.4.8 Repair step 8: Remove the blower housing / heat exchanger seal and the fuel connection grommet

- Firstly, carry out repair step 1, [Page 14](#) up to repair step 4, [Page 16](#).

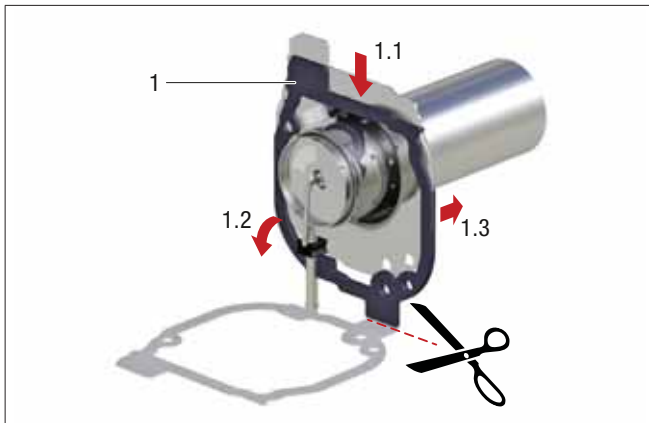

- Remove the seal (1) from the combustion chamber.

Note!

The folding seal can be cut for easier removal.

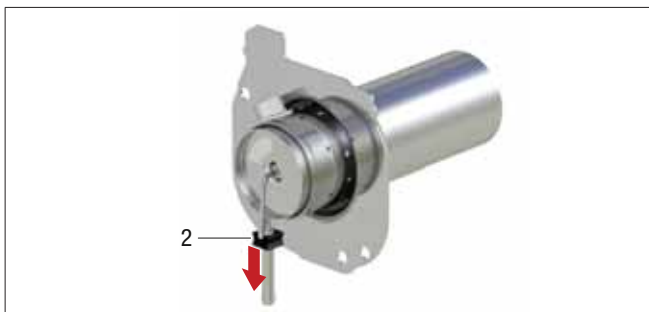

- Pull off the fuel connection grommet (2) from underneath.

Note!

- Illustration shows the combustion chamber of a diesel heater.
- Install the blower housing / heat exchanger seal and fuel connection grommet, [see page 18](#), point 1–32.

3.5 Assembling the heater

Caution!

Damage to unit caused by third party, damaged or deformed components

Installing third party, damaged or deformed components has a negative effect on the function of the heater.

- Replace damaged, deformed or defective components.
- Use original Eberspächer spare parts, see spare parts list.
- Use all the components included in spare parts kits.

3.5.1 Mount the fuel connection grommet and blower housing / heat exchanger seal

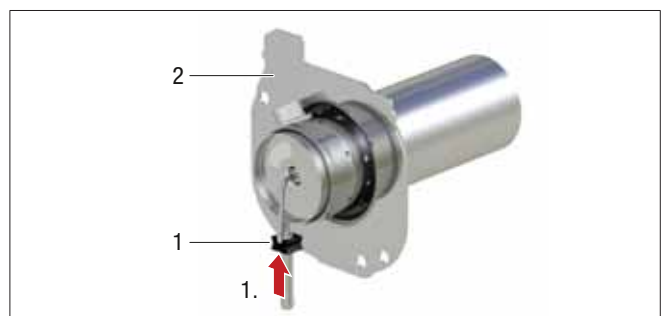

- Push on the fuel connection grommet (1). Bottom edge of the grommet is flush with the combustion chamber flange (2).

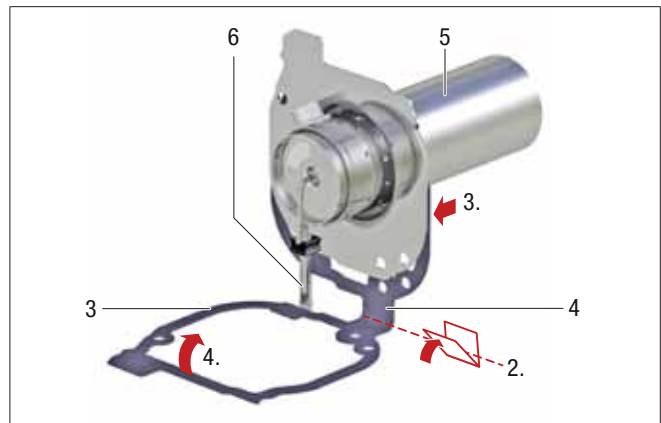

- Before installing fold the blower housing / heat exchanger seal (3) at the connecting web (4).
- Push the top part of the seal over the flame tube (5) up to the combustion chamber flange (2).
- Fold the bottom part of the seal up over the fuel connection (6).

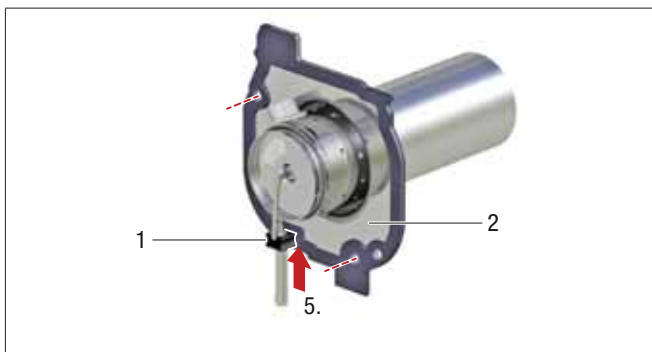

- Hold both seal parts together and push them upwards between the combustion chamber flange (2) and the fuel connection grommet (1). The drillholes in the seal and combustion chamber lie above each other.

i Note!

Figures: Diesel heater combustion chamber.

3.5.2 Install the glow plug

i Note!

Do not twist the glow plug connection cables.

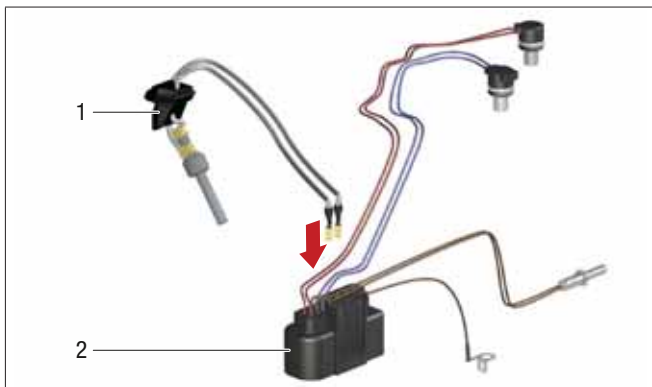

- After replacing the glow plug (1) or lead harness of the heater (2), plug the glow plug connection cables onto connector -XB4 in chamber 3 and 4.

3.5.3 Install the lead harness of the heater / flame sensor

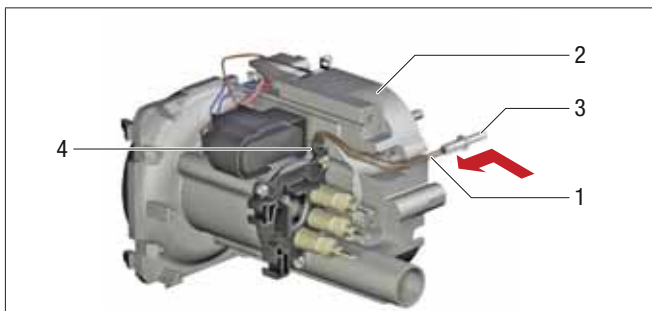

- Insert the flame sensor connection cables (1) in the blower housing (2).
- Push in the flame sensor (3).
- Hook the connection cables in the guide hook (4) on the electric motor.

3.5.4 Install the combustion chamber

⚠ Caution!

Unit damage due to unbalance

The impeller is pressed on precisely. If the heater is put down on the blower it can cause damage to the blower.

- Do not lay heater on its impeller.
- Always put down heater to the side.

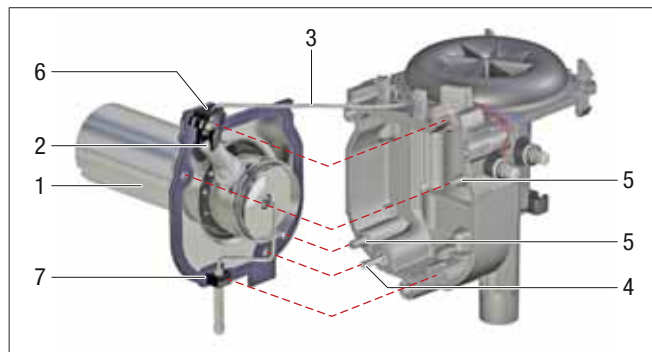

- Insert the glow plug (2) in the combustion chamber (1). The connection cables (3) point towards the middle of the unit.
- Place the combustion chamber on the blower housing, at the same time
- feed the flame sensor (4) and guide pins (5) into the drillholes in the combustion chamber flange.
- Push the glow plug grommet (6) and fuel connection grommet (7) into the corresponding recesses in the blower housing.
- Check the fit of the grommets. The grommets must be completely pushed in.

3.5.5 Installing the heat exchanger

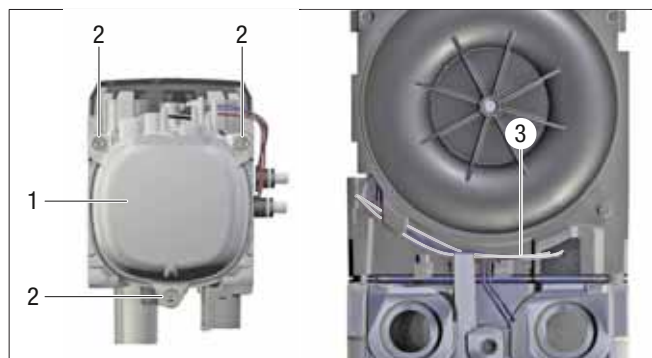

- Position the heat exchanger (1) on the flame tube and guide pins.
- Fix heat exchanger with thread-forming screws (2) M5 x 65. Tightening torque 7.5+0.7 Nm.
- Lay the glow plug connection cables (3) parallel in the guides, do not twist.

3.5.6 Install the water inlet sensor / water outlet sensor

Note!

- If the lead harness of the heater is re-used, always renew the O-rings of the sensor.
- If the lead harness of the heater has been renewed, grease the O-rings of the sensor.

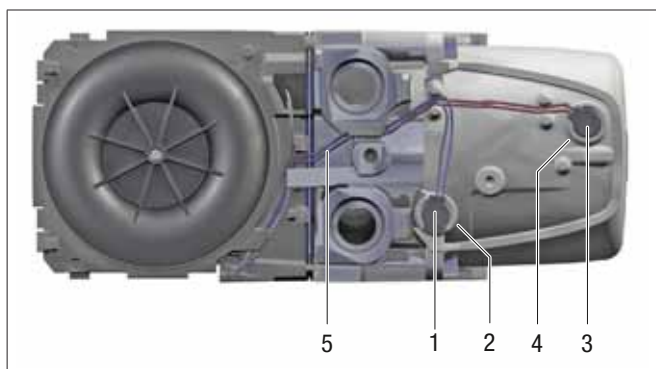

- Insert the water inlet sensor (1) (cables BU) in the holder (2).
- Insert the water outlet sensor (3) (cables RD) in the holder (4).
- Lay the sensor connection cables (5) in the guides as shown.

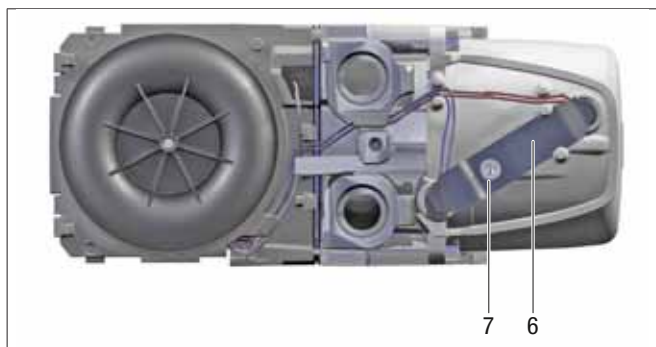

- Check the sensor compression spring (6) for damage and deformation. Renew damaged or deformed compression spring.
- Position the compression spring as shown and fix with thread-forming screw (7) M4 x 10. Tightening torque 3.8 ± 0.4 Nm.

3.5.7 Install water connection socket / sensor cover

Note!

- The sensor cover together with the screw is not a tool for pushing the water connection socket into the heat exchanger.
- Replace the O-rings.

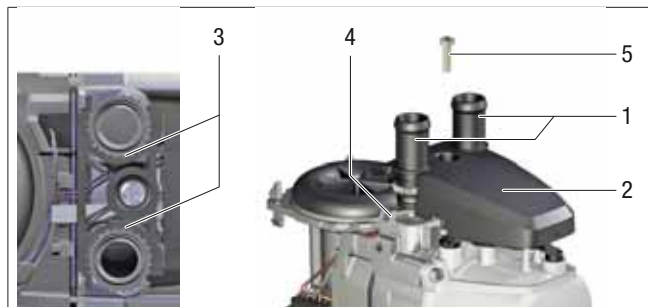

- Insert the water connection socket (1) in the sensor cover (2). The teeth (3) engage in each other.
- Insert the water connection socket in the holders (4) on the heat exchanger and press in, until the teeth sit on the heat exchanger.

Note!

If using an elbow socket, set the required direction.

- Push the sensor cover downwards and readjust the connection socket position until the teeth (3) engage once again.
- Fix the sensor cover with thread-forming screw (5) M5 x 18. Tightening torque 6.5+0.5 Nm.

3.5.8 Mounting the control box

Caution!

Damage to unit due to overload

An excessive tightening torque on the screw (12) overloads and damages the control box housing and causes malfunctions.

→ Keep to the specified tightening torque.

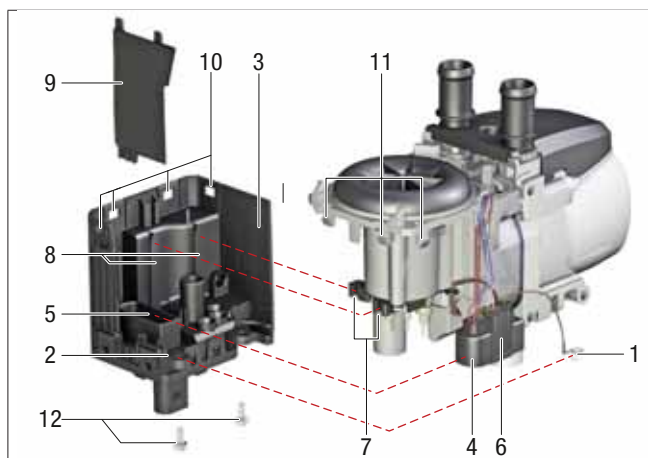

- Insert the ground cable (1) in the holder (2) on the control box (3).
- Push the connector (4) of the heater lead harness into the control box connection (5), until the locking device (6) snaps into position.
- Feed the guides (7) on the electric motor into the rails (8) on the

control box.

- Push the control box (3) upwards. The snap connections (10) latch onto the blower housing (11).
- Fix the control box with 2 thread-forming screws (12) M4 × 10. Tightening torque 2.8±0.3 Nm.
- Stow away the cables and push in the electric motor cover (9) from above.

3.5.9 Installing the blower cover



- Place the blower cover (1) on the blower housing (2) and push downwards, until the snap connections (3) latch into position.

3.5.10 Measure the fuel quantity

Preparing for the measurement

- Pull off the fuel pressure line from the heater and insert in a measuring cylinder (size 25 cm³).
- Switch on heater.
- Depending on the heater type, the metering pump starts pumping fuel after 17 to 20 sec. If the fuel comes out uniformly and free of bubbles, the fuel line is filled and vented.
- Switch off heater and empty measuring cylinder.

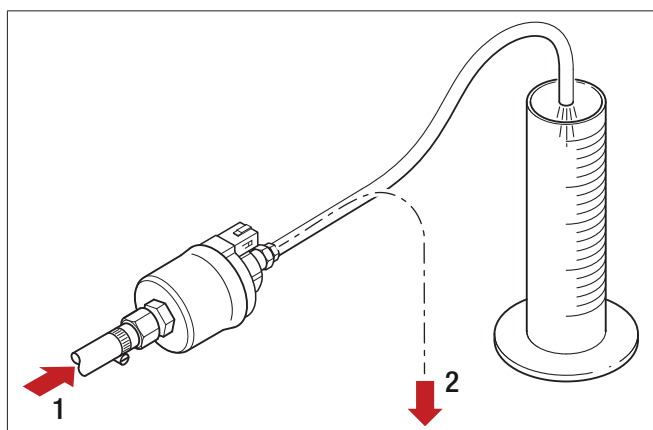

- 1 from the fuel tank
- 2 to the heater

Measurement

- Switch on heater.
- Depending on the heater type, the metering pump starts pumping fuel after 17 to 20 sec.
- During the measurement, hold the measuring cylinder at the level of the heater.
- In the case of petrol heaters, because of the delivery rate, it is sufficient to start once to measure the fuel quantity.
- In the case of diesel heaters, after starting once, two automatic

start repeats must take place to obtain sufficient fuel for the measurement.

- After measuring, switch off the heater.
- Read off the quantity of fuel in the measuring cylinder.

Evaluation

- Compare the measured quantity of fuel with the values in the following table.
- Measured fuel quantity above the maximum value or below the minimum value → replace the metering pump.

Heater type	Hydronic S3	
Heater version	B 4 E / B 5 E	D 4 E / D 5 E
Discharge period		
one-off start	75 sec.	86 sec.
Fuel quantity nominal [cm ³]	8.9	7.0
Max. fuel quantity [cm ³]	9.8	7.35
Min. fuel quantity [cm ³]	8.0	6.65

i Note!

- The given fuel quantities result from the initial start of the heater.
- Carry out the fuel measurement only if the battery is sufficiently charged. During the measurement at least 12 volt or max. 13 volt should be applied to the control box.

3.5.11 Measure fuel quantity with EasyScan

Preparation / measurement / evaluation

- Pull off the fuel line at the heater and insert it into a measuring cylinder (size 25 cm³).
- Make the connection between the heater and EasyScan diagnostic interface VCI. To do this, connect the EasyScan to the diagnostics connector of the cable harness.
- Start the EasyScan diagnostics software.
- In the "Diagnosis" menu, open the [Component activation] tab.
- Call up the [External components] submenu.
- Enter this test parameter in the [Metering pump] menu:
 - Frequency: 7 Hz
 - Duration: 60 seconds
- Press the [Start metering pump] button to start the measurement.
- Wait until the measurement process has ended, then read off the pumped quantity of fuel in the measuring centre.
- If the measured quantity of fuel lies outside the values listed in the table, the metering pump must be replaced.

Heater type	Hydronic S3 Economy	
Heater version	B 4 E / B 5 E	D 4 E / D 5 E
Delivery period in sec.	60 sec.	60 sec.
Fuel quantity, nominal [cm ³]	11.4	12.4
Fuel quantity - max. [cm ³]	12.5	13.6
Fuel quantity - min. [cm ³]	10.3	11.2

3.6 Hydronic S3 Economy component drawing

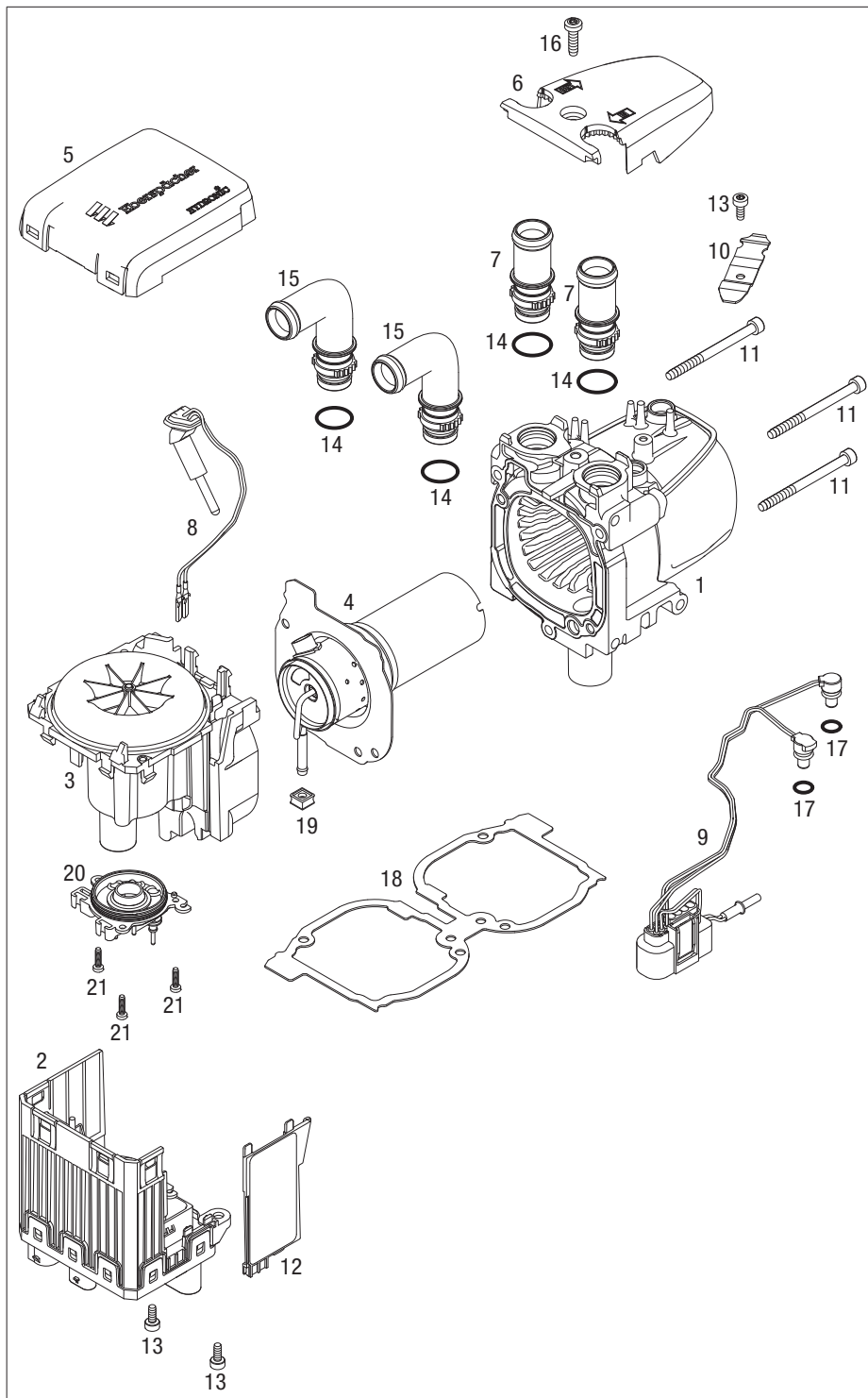

Parts list

- | | |
|----|--|
| 1 | Jacket and heat exchanger |
| 2 | Control box |
| 3 | Blower |
| 4 | Combustion chamber |
| 5 | Blower cover |
| 6 | Cover, sensor |
| 7 | Water connection socket, straight |
| 8 | Glow plug |
| 9 | Heater lead harness with water inlet sensor, water outlet sensor, ground cable, flame sensor |
| 10 | Compression spring |
| 11 | Screw, thread-forming, M5×65 (3x) |
| 12 | Cover, electric motor |
| 13 | Screw, thread-forming, M4×10 (2x) |
| 14 | O-ring, 16×2 |
| 15 | Water connection socket, angled |
| 16 | Screw, thread-forming, M5×18 |
| 17 | O-ring, 7.5×2 (2x) |
| 18 | Heat exchanger / blower seal |
| 19 | Fuel pipe grommet |
| 20 | Electric motor cover |
| 21 | Screw, M3×12 (3x) |

4 Electrics

4.1 Heater wiring

 **Caution!**

Unit damage due to improper electrical connection

The heater is to be connected up electrically according to the EMC directives. Improper interventions can affect the EMC.

- Do not damage the insulation of electrical cables.
- Avoid chafing, kinking, jamming or exposure to heat.
- Close off unused chambers of watertight connectors with filler plugs.
- Make the electrical corrosion-free and securely.
- Lubricate electrical connections outside the interior with contact grease.

 **Note!**

Note the following for the electrical wiring of the heater and the control unit:

- Position electrical cables and components in the vehicle so that they can function properly under normal operating conditions without impairment (e.g. due to heat exposure, moisture, etc.).
- Use correct cable cross-section between the battery and heater.
- For a cable length up to 6 m (positive and negative cable) the minimum cable cross-section is 4 mm².
- If the positive cable is connected to the fuse box (e.g. terminal 30), the vehicle's cable from the battery to the fuse box must be included in the calculation of the total cable length.
- Insulate unused cable ends.
- For circuit diagrams for the EasyStart control unit refer to the installation instructions of the control unit or the "Installation Instructions plus – EasyStart / Altitude Kit, Special Functions and Diagnosis", which are available to read and download from www.eberspaecher-standheizung.com/download.

4.2 Parts list for circuit diagram, heater and cable harness

- -A10 Control box
- -A30 Fuse holder 3-pin
- -B5 Flame sensor
- -B10 WAF (water outlet sensor)
- -B11 WEF (water inlet sensor)
- -F1 Fuse, heater
- -F2 Fuse, control unit
- -F3 Fan relay fuse
- -K1 Fan relay
- -M3 Burner motor
- -M10 Water pump
- -R1 Glow plug
- -R2 Terminating resistor 120 Ω
- -R3 Terminating resistor 9.2 kΩ
- -W1 Cable loom, water pump
- -W2 Cable loom, metering pump
- -X1 Ring terminal end
- -XB1 Bush housing, heater power supply
- -XB2 Bush housing, heater signals
- -XB3 Bush housing, heater water pump
- -XB6/1 Bush housing, tester / EasyScan
- -XB6/2 Bush housing, control unit
- -XB7 Relay block
- -XB8/1 Bush housing, metering pump plug-in connection
- -XB8/2 Bush housing, water pump
- -XS6/1 Mating connector with terminating resistor
- -XS8 Connector housing, metering pump plug-in connection
- -Y1 Fuel metering pump
 - a to the heater
 - b Activation, vehicle fan
 - c to the CAN control unit
 - c1 to the LIN control unit
 - d ADR acknowledgement button
 - n Generator input D+
 - o Input, power take-off NA+

 **Note**

- It must be ensured that if the battery isolating switch is pressed due to EMERGENCY STOP, all the heater's electric circuits are disconnected from the battery immediately (without any consideration of the heater's status).
- If the battery isolating switch is pressed to disconnect the battery from all electric circuits, the heater must be switched off first and if applicable you must wait until the heater's afterrun has finished.

- x insulate and tie back any cables that are not needed

Cable colours

RD	red	GR	grey	BK	black
BU	blue	YE	yellow	GN	green
WH	white	VT	violet	BN	brown

4.3 Heater circuit diagrams

4.3.1 Heater 12V CS

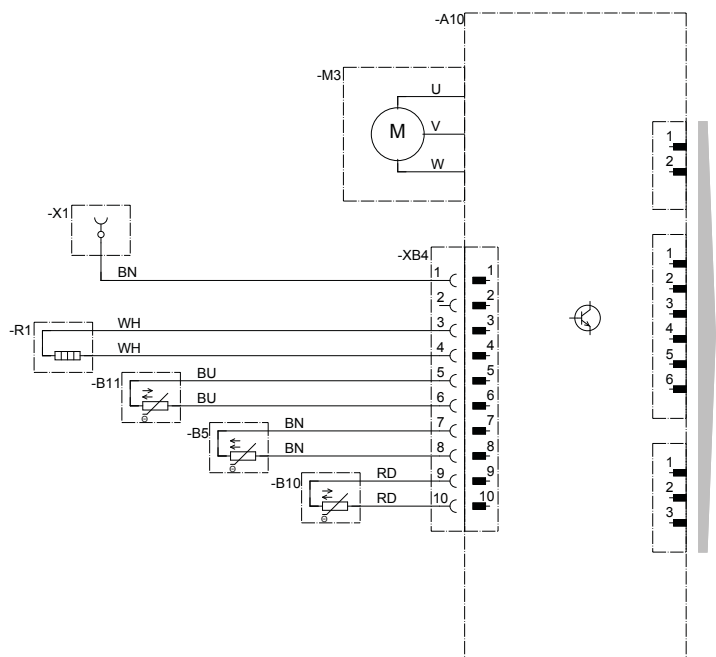
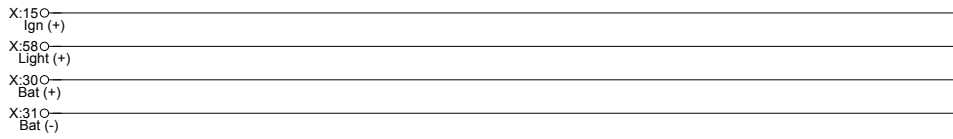

Parts list [see page 23](#)

25.2691.00.9601.0A

4.3.2 Heater 24V CS

- X:15 ○ _____
Ign (+)
- X:58 ○ _____
Light (+)
- X:30 ○ _____
Bat (+)
- X:31 ○ _____
Bat (-)

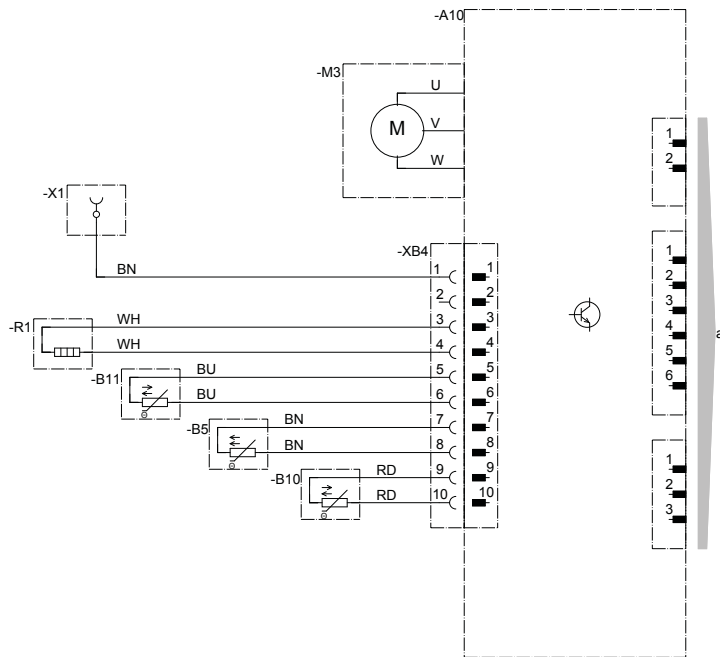

Parts list [see page 23](#)

25.2696.00.9601.0A

4.3.4 Cable harness 24V CS

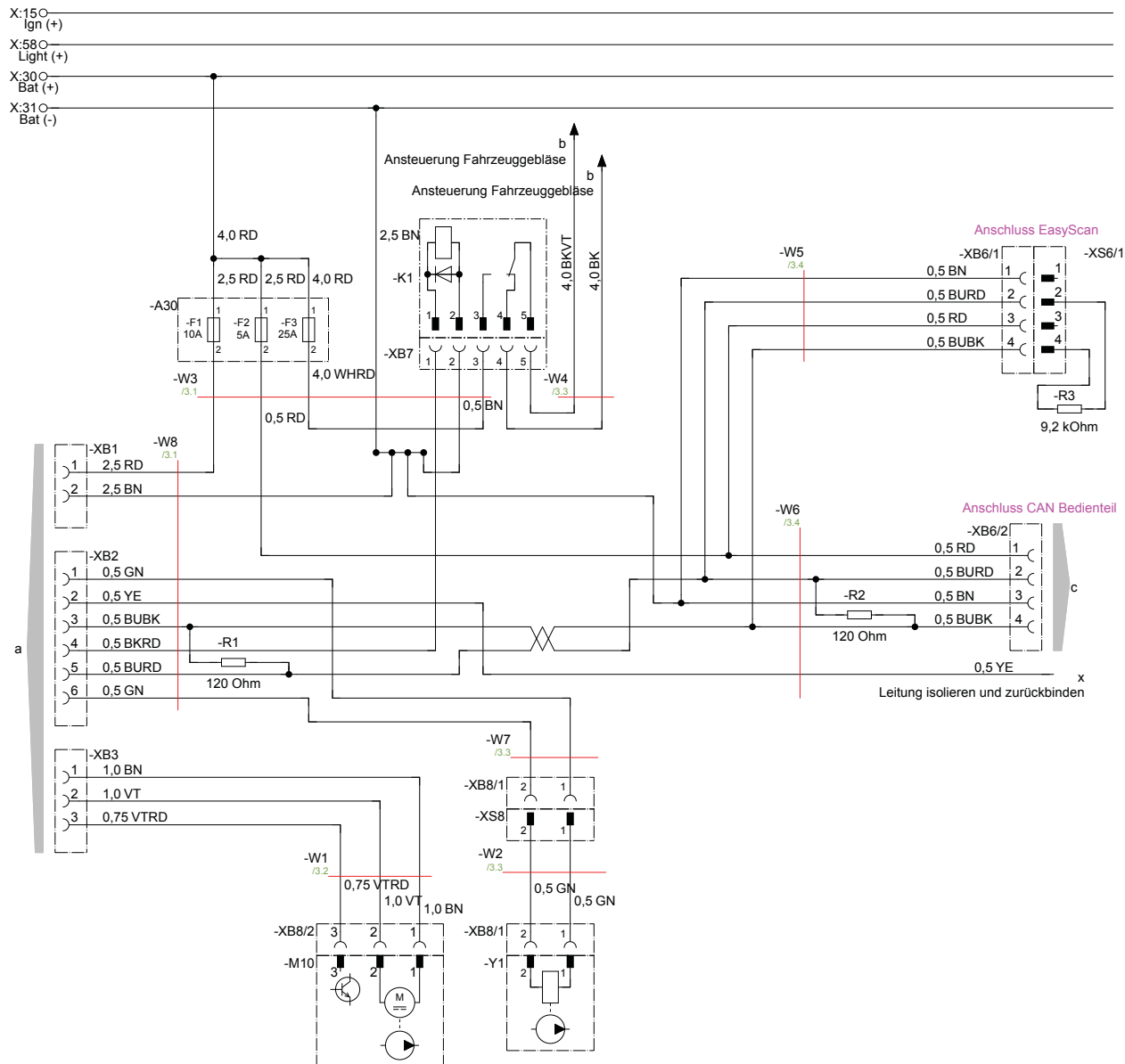

Parts list [see page 23](#)

25.2696.00.9602.0A

4.3.5 Cable harness 24V CS ADR

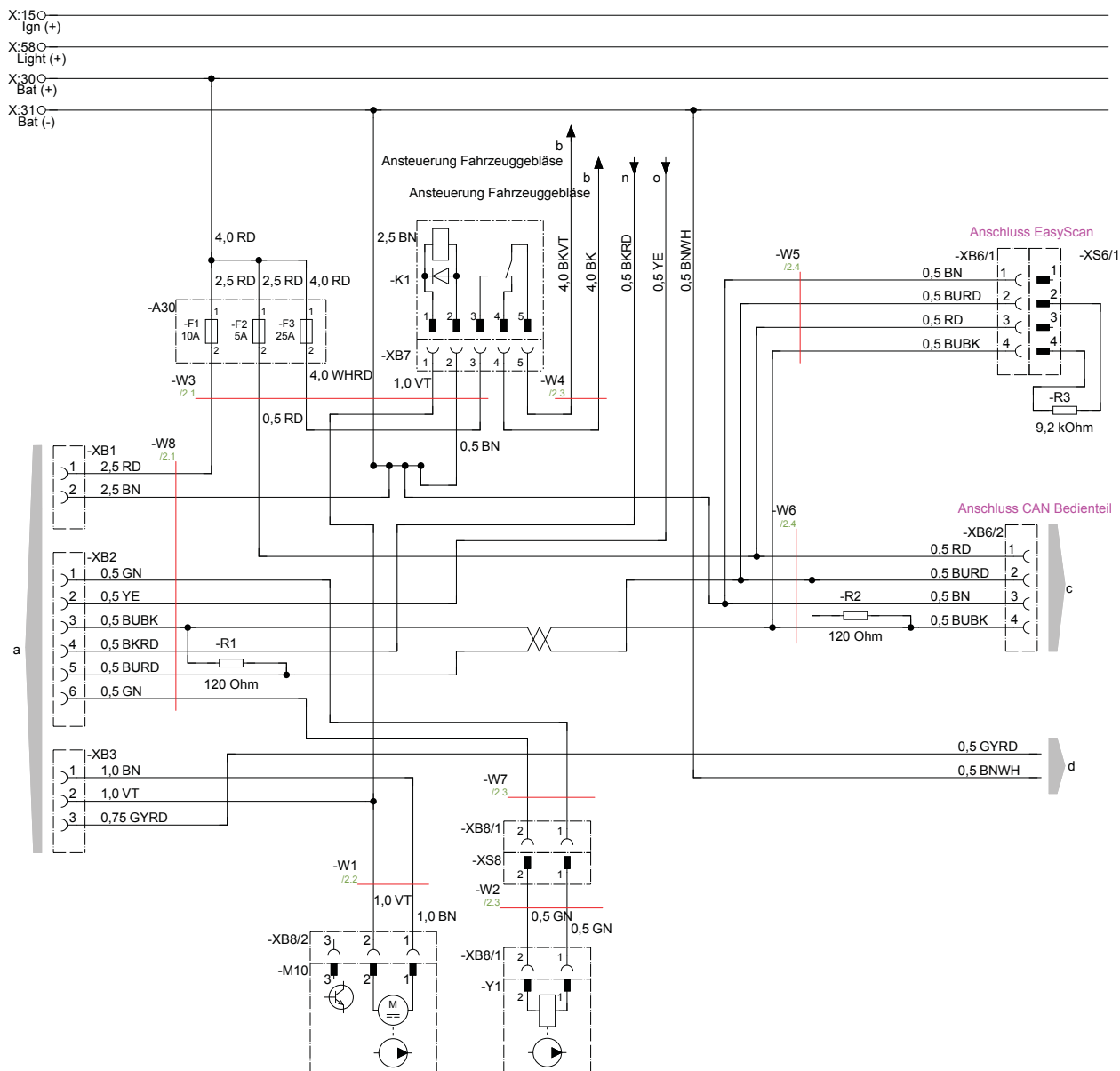

4.4 Circuit diagrams for control units

4.4.1 Easy Start Pro

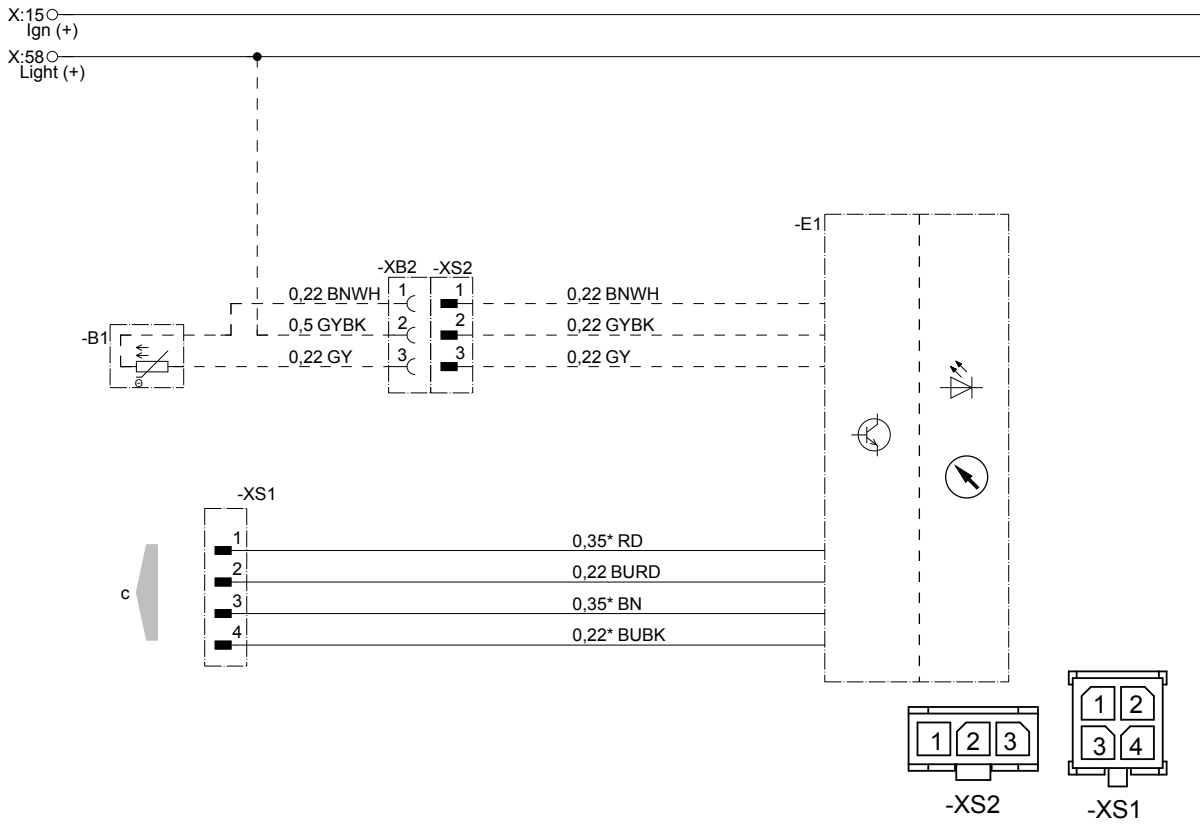

22.1000.34.9722

4.4.2 EasyStart Timer

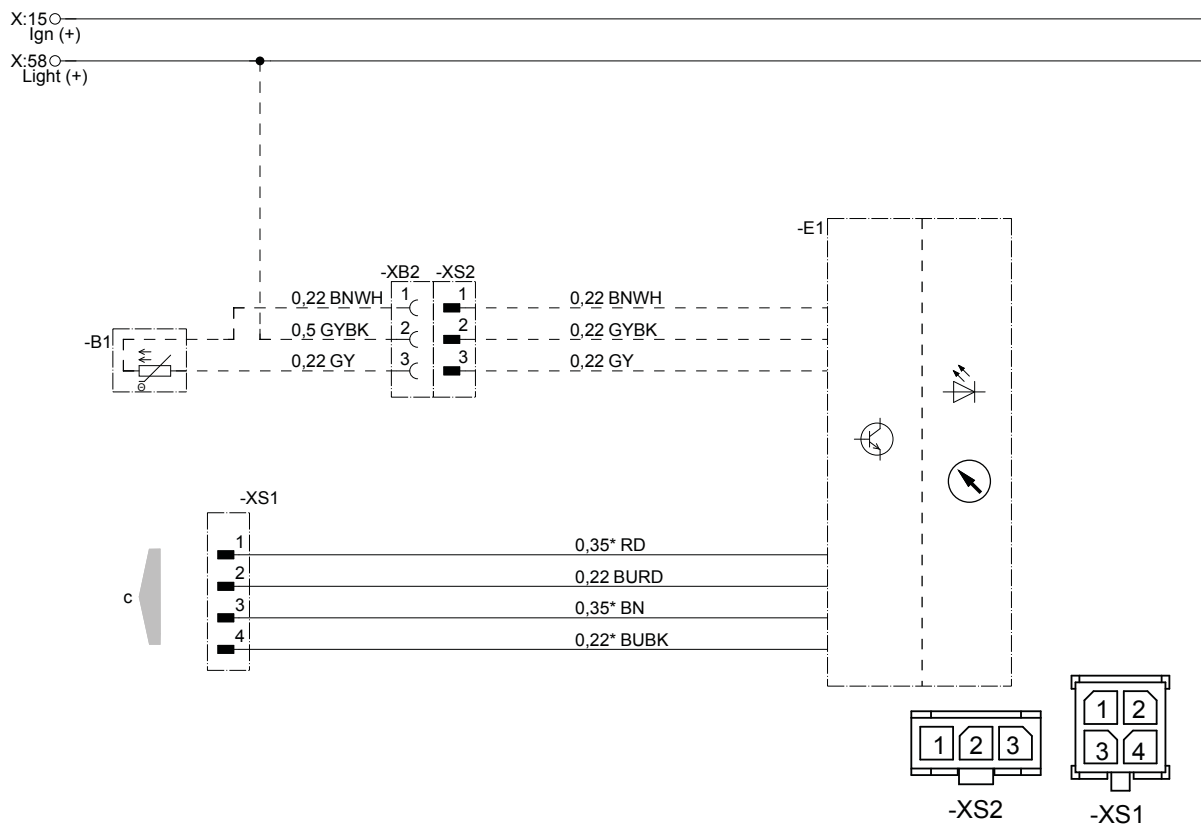

Parts list [see page 23](#)

25.2652.00.9601.0B

4.4.3 EasyStart Web

X:15 Ⓞ
Ign (+)

X:58 Ⓞ
Light (+)

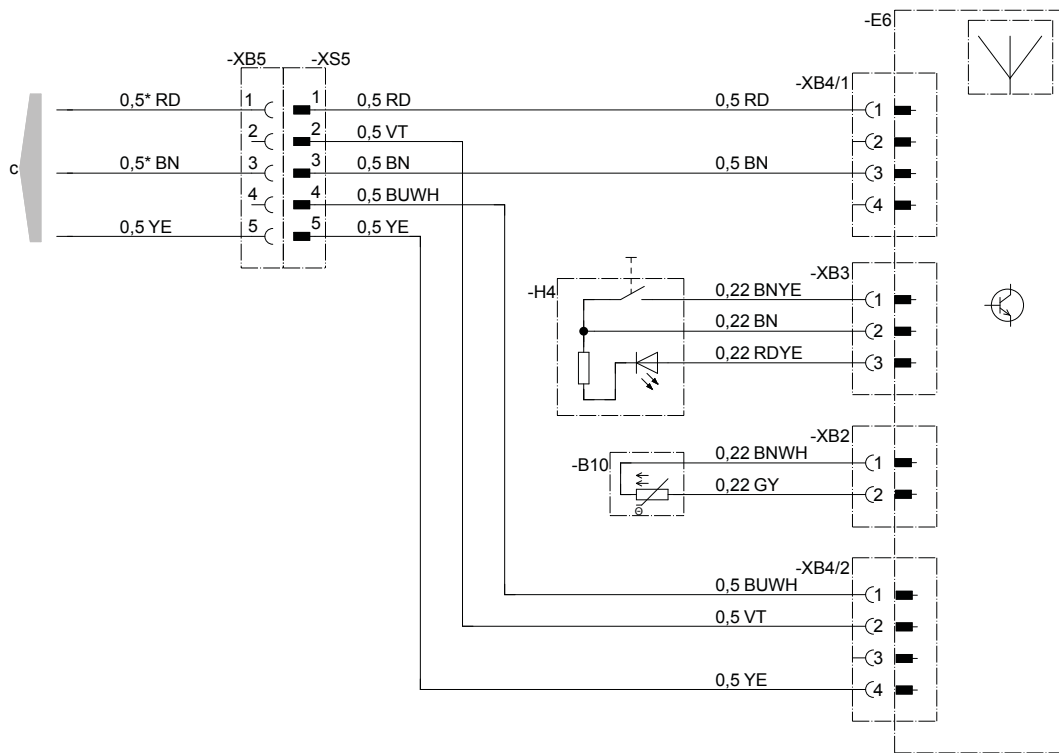

22.1000.34.9719.9A

5 Technical data

5.1 Petrol heater 12V CS

Heater type		Hydronic S3 Economy 12V CS			
		B 4 E CS		B 5 E CS	
Heater version					
Heating medium		Mixture of water and anti-freeze (Proportion of antifreeze at least 10 % up to 50 % maximum)			
Fuel		Petrol – standard commercially available (DIN 51600 and EN 228)			
Rated voltage		12 volt			
Control of the heat flow		Maximum	Minimum	Maximum	Minimum
Heat flow (watt)		4300	1800	5000	1800
Fuel consumption (l/h)		0.57	0.23	0.67	0.23
Average electrical power consumption (watt)		during operation		while starting	
without water pump, without vehicle fan relay		24	7	32	7
Operating range		10.5 volt			
Lower voltage limit: An undervoltage protection installed in the control box switches off the heater if the lower voltage limit is reached.					
Upper voltage limit: An overvoltage protection installed in the control box switches off the heater if the upper voltage limit is reached.		16 volt			
Allowable operating pressure		up to 2.5 bar overpressure max.			
Water volume in the heater		approx. 0.09 l			
Minimum water flow rate of the heater		300 l/h			
Allowable ambient temperature (Also note and follow the information for installation of the heater and metering pump!)		Heater		during operation	
				not in operation	
		Metering		during operation	
		pump		Storage	
		drawn-in combustion air		max. +25 °C, short-term +45 °C (15 minutes)	
Interference suppression class		5 (EN 55025)			
Weight – without coolant and attachments		2 kg			
Degree of protection DIN 40050, Part 9		Heater (in operation)		IP5K6K ¹⁾	
		Heater (not in operation)		IP5K9K ¹⁾	
Technical data, water pump					
Rated voltage		12 volt			
Nominal current		max. 1.6 A			
Nominal delivery pressure		0.2 bar			
Delivery rate		≥ 500 l/h			

1) The heater is protected against harmful quantities of dust, powerful water jet under increased pressure and water during high-pressure/steam cleaning (provided it is not in operation). The control box is dustproof, completely protected against powerful water jet under increased pressure and water during high-pressure/steam cleaning (provided it is not in operation).



Caution!

Operating the heater outside the specified technical data can cause malfunctions.

→ The technical data must be complied with at all times.



Note

If no other values are given, the technical data listed include the usual heater tolerances of ± 10 % at nominal voltage, 20 °C ambient temperature and Esslingen reference altitude.

5.2 Diesel heater 12V CS

Heater type		Hydronic S3 Economy 12V CS					
		D 4 E CS		D 5 E CS		D 6 E CS	
Heater version		D 4 E CS		D 5 E CS		D 6 E CS	
Heating medium		Mixture of water and anti-freeze (Proportion of antifreeze at least 10 % up to 50 % maximum)					
Fuel		Diesel – standard commercially available (EN 590) Blending with max. 30 % FAME according to EN 14214 is permitted.					
Rated voltage		12 volt					
Working range		Maximum	Minimum	Maximum	Minimum	Maximum	Minimum
Heat flow (watt)		4300	1300	5000	1300	5600	1300
Fuel consumption (l/h)		0.53	0.15	0.59	0.15	0.65	0.15
Average electrical power consumption (watt)		during operation		while starting			
		27	5	32	5	37	5
Operating range							
Lower voltage limit: An undervoltage protection installed in the control box switches off the heater if the lower voltage limit is reached.		10.5 volt					
Upper voltage limit: An overvoltage protection installed in the control box switches off the heater if the upper voltage limit is reached.		16 volt					
Allowable operating pressure		up to 2.5 bar overpressure max.					
Water volume in the heater		approx. 0.09 l					
Minimum water flow rate of the heater		300 l/h					
Allowable ambient temperature (Also note and follow the information for installation of the heater and metering pump!)		Heater		during operation		–40 °C to +80 °C	
				not in operation		–40 °C to +105 °C, short-term +125 °C (5 x 2h)	
		Metering pump		during operation		–40 °C to +50 °C	
				not in operation		–40 °C to +105 °C	
				drawn-in combustion air		max. +45 °C, short-term +80 °C (15 minutes)	
Interference suppression class		5 (EN 55025)					
Weight – without coolant and attachments		2 kg					
Degree of protection DIN 40050, Part 9		Heater (in operation)		IP5K6K ¹⁾			
		Heater (not in operation)		IP5K9K ¹⁾			
Technical data, water pump							
Rated voltage		12 volt					
Nominal current		max. 1.6 A					
Nominal delivery pressure		0.2 bar					
Delivery rate		≥ 500 l/h					

1) The heater is protected against harmful quantities of dust, powerful water jet under increased pressure and water during high-pressure/steam cleaning (provided it is not in operation). The control box is dustproof, completely protected against powerful water jet under increased pressure and water during high-pressure/steam cleaning (provided it is not in operation).



Caution!

Operating the heater outside the specified technical data can cause malfunctions.

→ The technical data must be complied with at all times.



Note

If no other values are given, the technical data listed include the usual heater tolerances of ± 10 % at nominal voltage, 20 °C ambient temperature and Esslingen reference altitude.

5.3 Diesel heater 24V CS

Heater type		Hydronic S3 Commercial 24V CS			
		D 5 L		D 6 L	
Heater version		D 5 L		D 6 L	
Heating medium		Mixture of water and anti-freeze (Proportion of antifreeze at least 10 % up to 50 % maximum)			
Fuel		Diesel – standard commercially available (EN 590) Blending with max. 30 % FAME according to EN 14214 is permitted.			
Rated voltage		24 volt			
Working range		Maximum	Minimum	Maximum	Minimum
Heat flow (watt)		5000	1300	5600	1300
Fuel consumption (l/h)		0.59	0.15	0.65	0.15
Average electrical power consumption (watt) without water pump, without vehicle fan relay		during operation		32	5
		while starting		37	
Operating range		135			
Lower voltage limit: An undervoltage protection installed in the control box switches off the heater if the lower voltage limit is reached.		20.4 volt			
Upper voltage limit: An overvoltage protection installed in the control box switches off the heater if the upper voltage limit is reached.		32 volt			
Allowable operating pressure		up to 2.5 bar overpressure max.			
Water volume in the heater		approx. 0.09 l			
Minimum water flow rate of the heater		300 l/h			
Allowable ambient temperature (Also note and follow the information for installation of the heater and metering pump!)		Heater		during operation	
				not in operation	
		Metering pump		during operation	
				not in operation	
		drawn-in combustion air		max. +45 °C, short-term +80 °C (15 minutes)	
Interference suppression class		5 (EN 55025)			
Weight – without coolant and attachments		2 kg			
Degree of protection DIN 40050, Part 9		Heater (in operation)		IP5K6K ¹⁾	
		Heater (not in operation)		IP5K9K ¹⁾	
Technical data, water pump					
Rated voltage		24 volt			
Electrical power consumption		max. 35 W			
Nominal delivery pressure		0.15 bar			
Delivery rate		1400 l/h			

1) The heater is protected against harmful quantities of dust, powerful water jet under increased pressure and water during high-pressure/steam cleaning (provided it is not in operation). The control box is dustproof, completely protected against powerful water jet under increased pressure and water during high-pressure/steam cleaning (provided it is not in operation).



Caution!

Operating the heater outside the specified technical data can cause malfunctions.

→ The technical data must be complied with at all times.



Note

If no other values are given, the technical data listed include the usual heater tolerances of $\pm 10\%$ at nominal voltage, 20 °C ambient temperature and Esslingen reference altitude.

6 Environment

6.1 Certifications

The high quality of Eberspächer products is the key to our success. To guarantee this quality, we have organised all work processes in the company along the lines of quality management (QM). Even so, we still undertake a large number of activities for continuous improvement of product quality in order to keep pace with the growing requirements of our customers.

All the steps necessary for quality assurance are stipulated in international standards. This quality is comprehensive. It affects products, procedures and customer / supplier relationships. Officially approved public experts assess the system and the corresponding certification company awards a certificate.

Eberspächer Climate Control Systems GmbH & Co. KG has already qualified for the following standards:

Quality management in accordance with

EN ISO 9001:2000 and ISO / TS 16949:1999

Environmental management system in accordance with

EN ISO 14001:1996

6.2 Disposal

6.2.1 Disposal of materials

Old units, defective components and packaging materials can be separated into their individual materials so that if necessary all parts can be disposed of in an environmentally friendly way or can be recovered and reused. Electric motors, control boxes and sensors (e.g. temperature sensors) are deemed to be "electronic scrap".

6.2.2 Dismantling the heater

The heater is dismantled according to the repair steps in this documentation.

6.2.3 Packaging

The packaging of the heater can be kept in case the heater has to be sent back.

6.3 Technical Support

If you have any technical questions or problems with the unit, the control unit or the operating software, please contact the following service address:

support-UK@eberspaecher.com

7 Service

7.1 Standard times

The standard times important for the guarantee are summarised in the following overview. The standard times are given as a work value.

1 work value (AW) = 6 minutes

The standard times are based on well-equipped garages/workshops and include all material and personal allowances taking into account the safety regulations.

Guarantee / warranty work must be carried out within these standard times.

Parts to be removed

Defective component	Work value (AW)	Control box	Electric motor cover	Sensor cover	Water connection socket / O-ring	Compression spring	Water inlet and outlet sensor/O-ring	Heat exchanger	Combustion chamber	Blower cover	Heater lead harness	Glow plug	Blower	Combustion chamber seal	Fuel pipe grommet
Control box	1.0	•	•												
Electric motor cover	1.0	•	•												
Sensor cover	1.0			•											
Water connection socket / O-ring	1.0			•	•										
Compression spring	1.0			•	•	•									
Water inlet and outlet sensor / O-ring	1.0			•	•	•	•								
Heat exchanger	1.0			•	•	•	•	•							
Combustion chamber	2.0			•	•	•	•	•	•	•	•	•		•	•
Blower cover	2.0			•	•										
Heater lead harness	2.0	•	•	•	•	•				•	•	•			
Glow plug	2.0	•	•	•	•	•	•	•	•	•	•	•		•	•
Blower	2.0	•		•	•			•	•	•	•	•	•	•	•
Combustion chamber seal	2.0			•	•	•	•	•	•	•	•	•		•	•
Fuel pipe grommet	2.0			•	•	•	•	•	•		•	•		•	•

Peripheral repair work

Diagnosis, fault memory, functional check	4.0
Fuel metering pump	2.0
Control unit	3.0
Water pump	4.0
Exhaust pipe	1.5
Exhaust silencer	2.5
Combustion air silencer	2.0
Combustion air hose	2.0
Replace the main fuse	1.0
Replace the combination valve	4.0
Replace the non-return valve	4.0

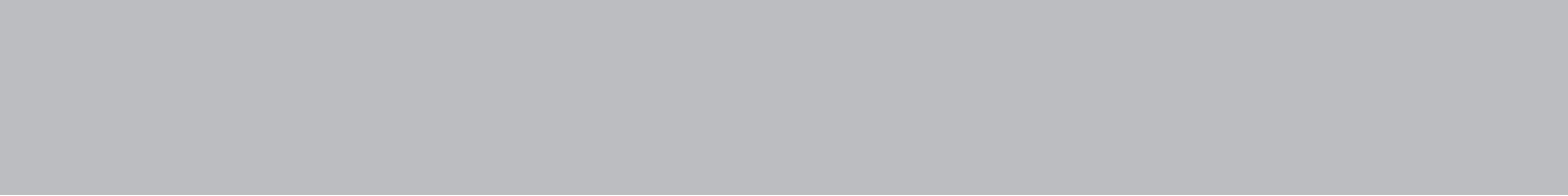

Eberspächer Climate Control
Systems GmbH & Co. KG
Eberspächerstraße 24
73730 Esslingen
Germany
info@eberspaecher.com
www.eberspaecher.com

