

# HYDRONIC II

Technical description, installation,  
operating and maintenance instructions.

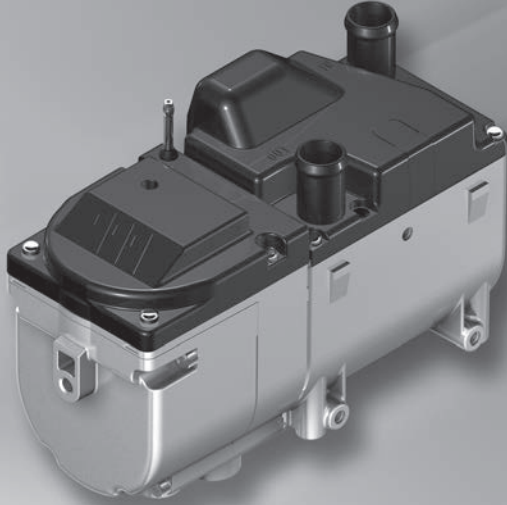

Heater for petrol

Hydronic II  
B 4 S – 12 V  
B 5 S – 12 V

Order No.

20 1909 05 00 00  
20 1904 05 00 00

Heater for diesel

Hydronic II  
D 4 S – 12 V  
D 5 S – 12 V

Order No.

25 2554 05 00 00  
25 2526 05 00 00

Hydronic II, with inlet pressure resistant metering pump  
D 4 S – 12 V  
D 5 S – 12 V

25 2558 05 00 00  
25 2557 05 00 00

**Engine-independent water heater  
for diesel and petrol.**



**Eberspächer**

A world of comfort

# 1 Introduction

## Contents

Chapter	Title	Content	Page
1	<b>Introduction</b>	<ul style="list-style-type: none"> <li>• Contents..... 2</li> <li>• Concept of this manual..... 3</li> <li>• Special text format and notation, presentation and picture symbols..... 4</li> <li>• Important information before starting work..... 4</li> <li>• Statutory regulations..... 5, 6</li> <li>• Safety instructions for installation and operation..... 7</li> <li>• Accident prevention..... 7</li> </ul>	
2	<b>Product information</b>	<ul style="list-style-type: none"> <li>• Order No. and scope of supply..... 8, 9</li> <li>• Technical data for petrol heaters ..... 10, 11</li> <li>• Technical data for diesel heaters ..... 12, 13</li> <li>• Main heater dimensions..... 14</li> <li>• Main dimensions of water pump, 12 volt..... 14</li> </ul>	
3	<b>Installation</b>	<ul style="list-style-type: none"> <li>• Installation location ..... 15</li> <li>• Permissible installation positions / heater and water pump ..... 16</li> <li>• Installation and fixing – water pump ..... 17</li> <li>• Installation and fixing – heater ..... 18</li> <li>• Installation of the angled water pipe sockets..... 19</li> <li>• Nameplate..... 19</li> <li>• Fix fuse holder and relay socket..... 20</li> <li>• Connection to the cooling water circuit ..... 20 – 23</li> <li>• Exhaust system ..... 24</li> <li>• Combustion air system ..... 25</li> <li>• Fuel supply ..... 26 – 30</li> </ul>	
4	<b>Operation and function</b>	<ul style="list-style-type: none"> <li>• Operating instructions..... 31</li> <li>• Important instructions for operation ..... 31               <ul style="list-style-type: none"> <li>– Initial commissioning ..... 31</li> <li>– Perform safety check before starting..... 31</li> <li>– Before switching on ..... 31</li> <li>– Parking ventilation..... 31</li> </ul> </li> <li>• Functional instruction..... 31               <ul style="list-style-type: none"> <li>– Switching on (parking heater mode) ..... 31</li> <li>– Heating mode ..... 31</li> <li>– Heating mode at altitudes ..... 32</li> </ul> </li> <li>• Control and safety device ..... 32</li> <li>• "EMERGENCY OFF" emergency shutdown ..... 32</li> </ul>	
5	<b>Electric</b>	<ul style="list-style-type: none"> <li>• Heater wiring ..... 33</li> <li>• Parts list for heater circuit diagram / circuit diagrams ..... 33 – 37</li> </ul>	
6	<b>Troubleshooting Maintenance Service</b>	<ul style="list-style-type: none"> <li>• If any faults occur, please check the following items ..... 38</li> <li>• Troubleshooting..... 38</li> <li>• Maintenance instructions ..... 38</li> <li>• Service ..... 38</li> </ul>	
7	<b>Environment</b>	<ul style="list-style-type: none"> <li>• Certification ..... 39</li> <li>• Disposal ..... 39</li> <li>• EU Declaration of Conformity..... 39</li> </ul>	
8	<b>List</b>	<ul style="list-style-type: none"> <li>• List of abbreviations..... 40</li> </ul>	



# 1 Introduction

---

## Concept of this manual

This manual aims to support the service company installing the heater and to provide the user with all important information about the heater.

The manual has been divided into 8 chapters to make it easier to find the corresponding information quickly.

### 1 Introduction

Here you find important introductory information about installation of the heater and about the structure of the manual.

### 2 Product information

Here you will find information about the scope of supply, the technical data and the dimensions of the heater.

### 3 Installation

Here you will find important information and instructions referring to installation of the heater.

### 4 Operation and function

Here you will find information about the operation and function of the heater.

### 5 Electric

Here you will find information about the electronic system and electronic components of the heater.

### 6 Troubleshooting / maintenance / service

Here you will find information on possible faults, maintenance and technical support.

### 7 Environment

Here you will find information about certification and disposal of the heater together with the EU Declaration of Conformity.

### 8 List

Here you will find the list of abbreviations.

# 1 Introduction

## Special test structure, presentation and picture symbols

This manual uses special text structures and picture symbols to emphasize different contents. Please refer to the following examples for their meanings and appropriate action.

### Special text formats and presentations

A dot (•) indicates a list which is started by a heading. If an indented dash (–) follows a dot, this list is subordinate to the dot.

### Picture symbols



#### Regulation!

This picture symbol with the remark “Regulation!” refers to a statutory regulation. Failure to comply with this regulation results in expiry of the type-approval for the heater and preclusion of any guarantee and liability claims on Eberspächer Climate Control Systems GmbH & Co. KG.



#### Danger!

This picture symbol with the remark “Danger!” refers to the risk of a fatal danger to life and limb. Under certain circumstances, failure to comply with these instructions can result in severe or life-threatening injuries.



#### Caution!

This picture symbol with the remark “Caution” refers to a dangerous situation for a person and / or the product. Failure to comply with these instructions can result in injuries to people and / or damage to machinery.

#### Please note!

These remarks contain recommendations for use and useful tips for installation of the heater.

## Important information before starting work

Range of application of the heater

The heater is intended for installation in the following vehicles:

- All kinds of vehicles
- Construction machinery
- Agricultural machinery
- Boats, ships and yachts

#### Please note!

The heater **cannot** be installed in vehicles used for the transport of dangerous goods according to ADR.

### Intended purpose of the heater (via the vehicle's own heat exchanger)

- Pre-heating, de-misting windows
- Heating and keeping the following warm:
  - Driver and working cabs
  - Freight compartments
  - Ship's cabins
  - Passenger and crew compartments
  - Vehicle engines and units

On account of its functional purpose, the heater is **not** permitted for the following applications:

- Long-term continuous operation, e.g. for pre-heating and heating of:
  - Residential rooms
  - Garages
  - Work huts, weekend homes and hunting huts
  - Houseboats, etc.



#### Caution!

### Safety instructions for the range of application and proper, intended use!

The heater must only be used and operated for the range of application stated by the manufacturer in compliance with the “Operation instructions” included with every heater.



# 1 Introduction

## Statutory regulations

The Federal Motor Transport Authority has issued an “EC type approval”, “EMC type-approval” and the approval for a component according to ECE R122 and ECE-R10 for the heater for installation in motor vehicles with the following official type-approval marks, noted on the heater name plate.

Heater type:	ECE type approval mark:
Hydronic II	 122 R – 000275 10 R – 045886

## § Regulations!

**Excerpt from ECE regulation No. 122 of the European Parliament and the Council**

### General regulations

- **Operating state display**
  - A clearly visible operating display in the user’s field of vision must indicate when the heater is switched on and off.

### Regulations concerning installation in the vehicle

- **Scope**
  - Subject to differing stipulations in the following section, combustion heaters must be installed according to the regulations 5.3 of ECE-R122.
  - It is assumed that Class O vehicles with heaters for liquid fuel conform to the regulations 5.3 of ECE-R122.
- **Arrangement of the heater**
  - Parts of the structure and other components near the heater must be protected from excessive heat exposure and possible fuel or oil contamination.
  - The heater must not pose a fire hazard even when it overheats. This requirement is deemed to be fulfilled if adequate clearance is ensured for all parts during installation, sufficient ventilation is provided and fireproof materials or heat shields are used.
  - The heater must not be mounted in the passenger compartment of vehicles in class M<sub>2</sub> and M<sub>3</sub>. However, a heater in a hermetically sealed enclosure which also complies with the aforementioned conditions may be used.

- The factory nameplate or duplicate must be affixed so that it can still be easily read when the heater is installed in the vehicle.
- All appropriate precautions must be taken when arranging the heater to minimise the risk of injuries to persons or damage to other property.

- **Fuel supply**

- The fuel intake connection must not be located in the passenger compartment and must be sealed with a properly closing lid to prevent any fuel leaks.
- In heaters for liquid fuel where the heater fuel is separate from the vehicle fuel, the type of fuel and intake connection must be clearly identified.
- A warning sign is to be fixed to the intake connection indicating that the heater must be switched off before refuelling.

- **Exhaust system**

- The exhaust outlet must be arranged so as to prevent any penetration of exhaust fumes into the vehicle interior through the ventilation system, warm air intakes or open windows.

- **Combustion air intake**

- The air for the heater’s combustion chamber must not be sucked in from the vehicle’s passenger compartment.
- The air intake must be arranged or protected in such a way that it cannot be blocked by other objects.

- **Automatic control of the heating system**

- If the engine fails, the heating system must be automatically switched off and the fuel supply stopped within 5 seconds. The heater may remain in operation if a manual device has already been activated.

### Please note!

The heater is **not** approved for installation in the interior of Class M<sub>1</sub> vehicles (vehicles for passenger transport / cars) and N vehicles (vehicles for the transport of goods).

# 1 Introduction

---

## Statutory regulations

### Please note!

- Compliance with the statutory regulations, the additional regulations and the safety instructions is prerequisite for guarantee and liability claims. Failure to comply with the statutory regulations and safety instructions and incorrect repairs, even if original spare parts are used, make the guarantee null and void and preclude any liability for Eberspächer Climate Control Systems GmbH & Co. KG.
- Subsequent installation of this heater must comply with these installation instructions.
- The statutory regulations are binding and must also be observed in countries which do not have any special regulations.
- When installing the heater in vehicles not subject to the German Road Traffic Licensing Regulations (StVZO), for example ships, the respective specially valid regulations and installation instructions must be observed.
- Installation of the heater in special vehicles must comply with the regulations applying to such vehicles.
- Other installation requirements are given in the relevant sections of this manual.



# 1 Introduction

## Safety instructions for installation and operation



### Danger!

#### Risk of injury, fire and poisoning!

- Disconnect the vehicle battery before starting any kind of work.
- Before working on the heater, switch the heater off and let all hot parts cool down.
- The heater must not be operated in closed rooms, e.g. in the garage or in a multi-storey car park.



### Caution!

#### Safety instructions for installation and operation!

- The heater must only be installed by a JE partner authorised by the manufacturer according to the instructions in this manual and possibly according to special installation recommendations; the same applies to any repairs to be carried out in the case of repairs or guarantee claims.
  - Repairs by non-authorised third-parties or with not original spare parts are dangerous and therefore not allowed. They result in expiry of the type-approval of the heater; consequently, when installed in motor vehicles they can cause expiry of the vehicle operating licence.
  - The following are not allowed:
    - Changes to components relevant to the heater.
    - Use of third-party components not approved by Eberspächer Climate Control Systems GmbH & Co. KG.
    - Installation or operation not conforming to the statutory regulations, safety instructions or specifications relevant for safe operation as stated in the installation instructions and operating instructions. This applies in particular to the electrical wiring, fuel supply, combustion air system and exhaust system.
  - Only original accessories and original spare parts must be used during installation or repairs.
  - Only control units approved by Eberspächer may be used to operate the heater. Use of other control units can cause malfunctions.
  - Before the heater is installed again in another vehicle, rinse the heater parts carrying water with clear water.
- When carrying out electric welding on the vehicle, the positive cable at the battery should be disconnected and placed at ground to protect the control box.
  - Do **not** operate the heater anywhere where there are readily flammable materials (e.g. dry grass, leaves, paper, etc.) in the area of the exhaust system or where ignitable fumes and dust can form, e.g. near a
    - fuel depot
    - coal depot
    - wood depot
    - grain depots, etc.
  - The heater must be switched off when refuelling.
  - If the heater is fitted in a safety casing, etc., the heater's installation box must not be used as storage space and must be kept clear. In particular fuel canisters, oil cans, spray cans, gas cartridges, fire extinguishers, cleaning rags, items of clothing, paper etc. must not be stored or transported on or next to the heater.
  - Defect fuses must only be replaced by fuses with the prescribed rating.
  - If fuel leaks from the heater fuel system, arrange for the damage to be repaired immediately by a JE service partner.
  - When topping up cooling water, only use coolants approved by the vehicle manufacturer; please refer to the vehicle's operating manual. Blending with coolants not approved for use can cause damage to the engine and heater.
  - The after-running of the heater must not be prematurely interrupted, e.g. by pressing the battery disconnecter, except for an emergency stop.

#### Please note!

Following installation, attach the "Switch off heater before refuelling!" sticker near the tank filler neck.

## Accident prevention

General accident prevention regulations and the corresponding workshop and operating safety instructions are to be observed.

## 2 Product information

### Order No. and scope of supply

#### Petrol heaters

Quantity / Designation	Order no.
1 Hydronic II – 12 volt B 4 S	20 1909 05 00 00
1 Hydronic II – 12 volt B 5 S	20 1904 05 00 00

#### Diesel heaters

Quantity / Designation	Order no.
1 Hydronic II – 12 volt D 4 S	25 2554 05 00 00
1 Hydronic II – 12 volt with inlet pressure resistant metering pump D 4 S	25 2558 05 00 00
1 Hydronic II – 12 volt D 5 S	25 2526 05 00 00
1 Hydronic II – 12 volt with inlet pressure resistant metering pump D 5 S	25 2557 05 00 00

To be ordered separately (applies to all heaters):

1 Control unit*	----
1 Universal installation kit	25 2526 80 00 00
1 Universal installation kit if using EasyStart Timer, Remote, Remote+ or Select	25 2526 81 00 00

\* For details of control units, please refer to the price list or product information.

### Heater scope of supply – see Fig. page 9

Figure No.	Designation
1	Heater
2	Metering pump**
3	Water pump
–	CD – Technical documentation

\*\* The scope of supply of the Hydronic D 4 S, Order No. 25 2558 05 00 00 and Hydronic D 5 S, Order No. 25 2557 05 00 00 heaters includes an inlet pressure resistant metering pump up to 2.0 bar (see page 28).

### Installation kit scope of supply – see Fig. page 9

Figure No.	Designation
4	Exhaust silencer
5	Cable harness, heater
6	Bracket, heater
7	Water hose
8	Flexible exhaust pipe, 900 mm long
9	Flexible exhaust pipe end, 300 mm long
10	Z-bracket, exhaust silencer
11	L-bracket, exhaust silencer
12	Bracket, metering pump
13	Combustion air hose, 760 mm long
14	Bracket, water pump
15	Cable loom, water pump
16	90° water pipe socket, 2x
17	Elbow, 105°
18	Pipe, 4 x 1.25, transparent
19	Pipe, 4 x 1, blue
20	Adapter, Ø 7.5 / 3.5
21	Combination bracket
22	Lead harness, blower
23	Relay for blower
24	Lead harness, metering pump
25	Tank extractor
26	Screw M6 x 15

#### Cable harnesses

A	Connection, control units
B	Plus supply connection, blower relay
C	Activation, vehicle blower
D	Minus supply connection
E	Connection to terminal 85 (1-pin, br)
F	Connection to terminal 86 (1-pin, rt/sw)
G	Diagnosis query connector connection
H	Plus supply connection

#### Please note!

- If the Hydronic II – B 5 S heater is to be run on E85 ethanol fuel (EN 15 293), the "fuel lines for E85" kit, Order No. 22 1000 20 31 00 is required in addition to the universal installation kit.
- Parts without a figure no. are small parts and packed in a bag.
- Please refer to the production information if any other parts are required for the installation.
- The self-tapping screws included in the scope of supply can be used for a sheet metal thickness of 2 – 6 mm (tightening torque 9<sup>+1</sup> Nm).



## 2 Product information



### Scope of supply – heater and installation kit

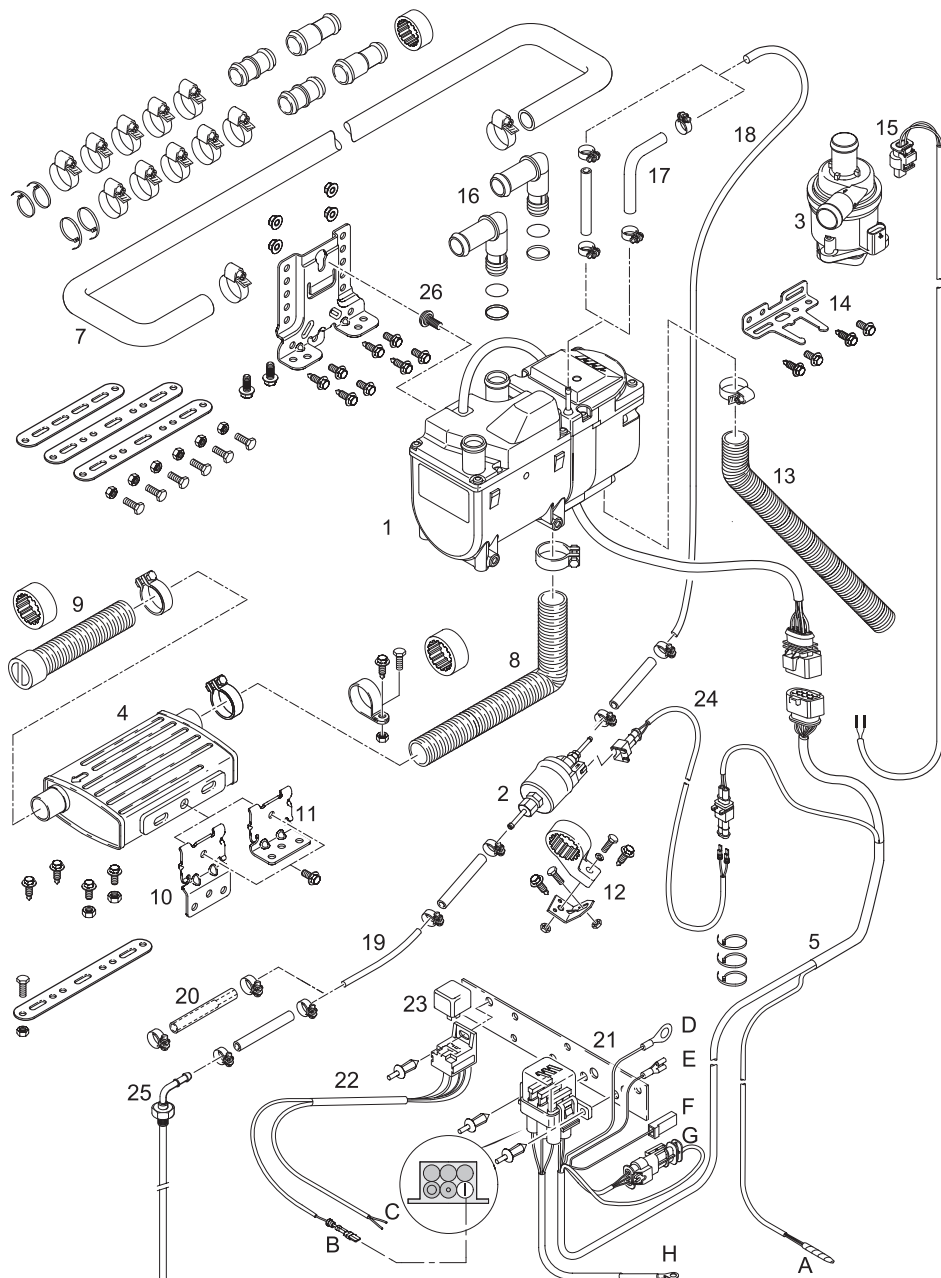

## 2 Product information

### Technical data for the petrol heater

Heater type	<b>Hydronic II</b>		
Heater version	B 4 S		
Heating medium	Mixture of water and coolant (max. 50 % coolant)		
Fuel – see also “Fuel Quality” – page 30	Petrol – standard commercially available (DIN 51600 and EN 228)		
Rated voltage	12 volt		
Control of the heat flow	Power	High	Low
Heat flow (watt)	4400	4000	2300
Fuel consumption (l/h)	0.62	0.55	0.32
Average electrical power consumption without waterpump (watt)	during operation	27	12
	while starting	120	
Operating range			
<ul style="list-style-type: none"> <li>Lower voltage limit: An undervoltage protection installed in the control box switches off the heater if the lower voltage limit is reached.</li> </ul>	10.5 volt		
<ul style="list-style-type: none"> <li>Upper voltage limit: An overvoltage protection installed in the control box switches off the heater if the upper voltage limit is reached.</li> </ul>	16 volt		
Allowable operating pressure	up to 2.5 bar overpressure max.		
Water volume in the heater	approx. 0.18 l		
Minimum water flow rate of the heater	250 l/h		
Permissible ambient temperature	during operation	without operation	
	Heater, continuous	-40 °C to +60 °C	-40 °C to +105 °C
	Heater, short time	---	+125 °C (5x2 h)
Coolant water temperature	continuous	-40 °C to +120 °C	-40 °C to +120 °C
	short time	---	125 °C (1 h)
Radio interference suppression level	5 (DIN 55025)		
Weight – without coolant and attachments	approx. 2.4 kg		

### Technical data for the water pump

Rated voltage	12 volt
Electrical power consumption	< 12 watt
Delivery rate	680 l/h
Delivery pressure difference	0.1 bar



#### Caution!

#### Safety instructions for technical data!

Failure to comply with the technical data can result in malfunctions.

#### Please note!

If no limit values are given, the technical data listed is with the usual heater tolerances of  $\pm 10\%$  at nominal voltage and Esslingen reference altitude.



## 2 Product information

### Technical data for the diesel heater

Heater type	<b>Hydronic II</b>		
Heater version	D 4 S		
Heating medium	Mixture of water and coolant (max. 50 % coolant)		
Fuel – see also “Fuel Quality” – page 30	Diesel – standard commercially available (EN 590) Blending with max. 20 % FAME according to EN 14214 is permitted		
Rated voltage	12 volt		
Control of the heat flow	Power	High	Low
Heat flow (watt)	4300	4100	2100
Fuel consumption (l/h)	0.52	0.50	0.26
Average electrical power consumption without waterpump (watt)	during operation	27	21
	while starting	120	
Operating range			
<ul style="list-style-type: none"> <li>Lower voltage limit: An undervoltage protection installed in the control box switches off the heater if the lower voltage limit is reached.</li> </ul>	10.5 volt		
<ul style="list-style-type: none"> <li>Upper voltage limit: An overvoltage protection installed in the control box switches off the heater if the upper voltage limit is reached.</li> </ul>	16 volt		
Allowable operating pressure	up to 2.5 bar overpressure max.		
Water volume in the heater	approx. 0.18 l		
Minimum water flow rate of the heater	250 l/h		
Permissible ambient temperature	during operation	without operation	
	Heater, continuous	-40 °C to +60 °C	-40 °C to +105 °C
	Heater, short time	---	+125 °C (5x2 h)
Coolant water temperature	continuous	-40 °C to +120 °C	-40 °C to +120 °C
	short time	---	125 °C (1 h)
Radio interference suppression level	5 (DIN 55025)		
Weight – without coolant and attachments	approx. 2.4 kg		

### Technical data for the water pump

Rated voltage	12 volt
Electrical power consumption	< 12 watt
Delivery rate	680 l/h
Delivery pressure difference	0.1 bar



#### Caution!

#### Safety instructions for technical data!

Failure to comply with the technical data can result in malfunctions.

#### Please note!

If no limit values are given, the technical data listed is with the usual heater tolerances of  $\pm 10\%$  at nominal voltage and Esslingen reference altitude.



## 2 Product information

### Technical data for the diesel heater

Heater type	<b>Hydronic II</b>		
Heater version	D 5 S		
Heating medium	Mixture of water and coolant (max. 50 % coolant)		
Fuel – see also “Fuel Quality” – page 30	Diesel – standard commercially available (EN 590) Blending with max. 20 % FAME according to EN 14214 is permitted		
Rated voltage	12 volt		
Control of the heat flow	Power	High	Low
Heat flow (watt)	5200	5000	2100
Fuel consumption (l/h)	0.64	0.61	0.26
Average electrical power consumption without waterpump (watt)			
during operation	40	37	12
while starting	120		
Operating range			
• Lower voltage limit: An undervoltage protection installed in the control box switches off the heater if the lower voltage limit is reached.	10.5 volt		
• Upper voltage limit: An overvoltage protection installed in the control box switches off the heater if the upper voltage limit is reached.	16 volt		
Allowable operating pressure	up to 2.5 bar overpressure max.		
Water volume in the heater	approx. 0.18 l		
Minimum water flow rate of the heater	250 l/h		
Permissible ambient temperature	during operation	without operation	
Heater, continuous	-40 °C to +80 °C	-40 °C to +110 °C	
Heater, short time	---	+125 °C (5x2 h)	
Coolant water temperature	continuous	-40 °C to +120 °C	
short time	---	125 °C (1 h)	
Radio interference suppression level	5 (DIN 55025)		
Weight – without coolant and attachments	approx. 2.4 kg		

### Technical data for the water pump

Rated voltage	12 volt
Electrical power consumption	< 12 watt
Delivery rate	680 l/h
Delivery pressure difference	0.1 bar



#### Caution! Safety instructions for technical data!

Failure to comply with the technical data can result in malfunctions.

#### Please note!

If no limit values are given, the technical data listed is with the usual heater tolerances of  $\pm 10\%$  at nominal voltage and Esslinger reference altitude.

## 2 Product information

### Main heater dimensions

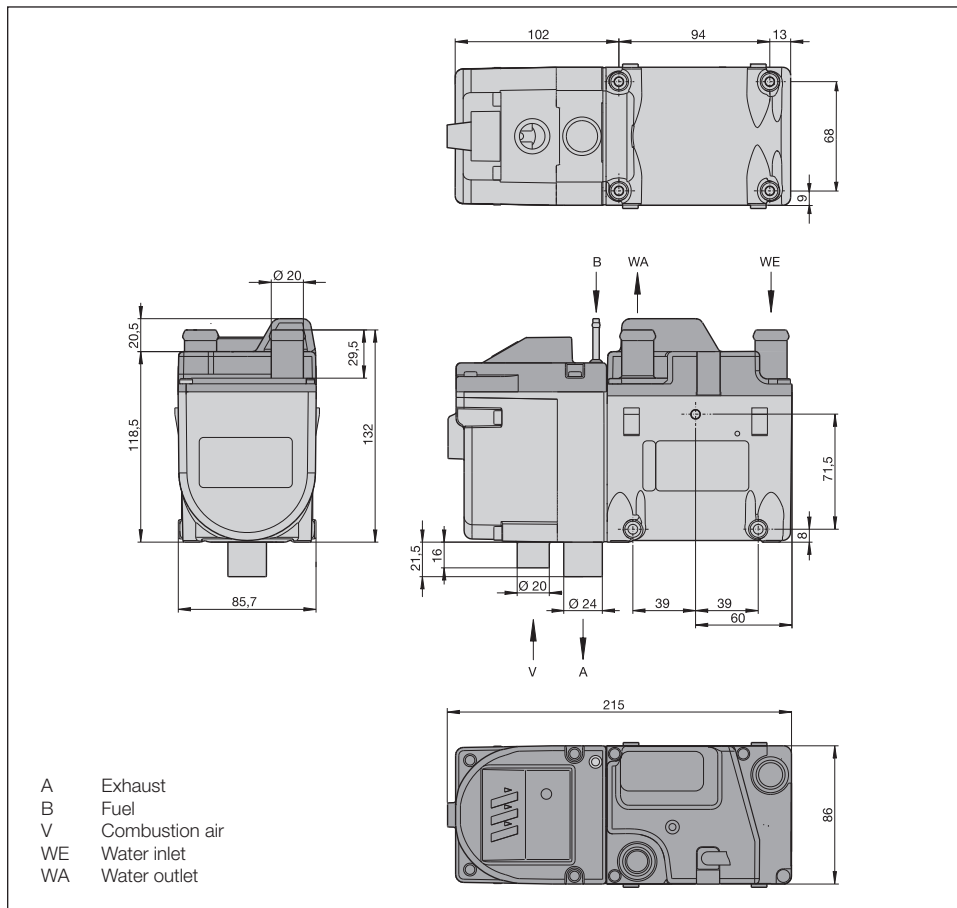

### Main water pump dimensions

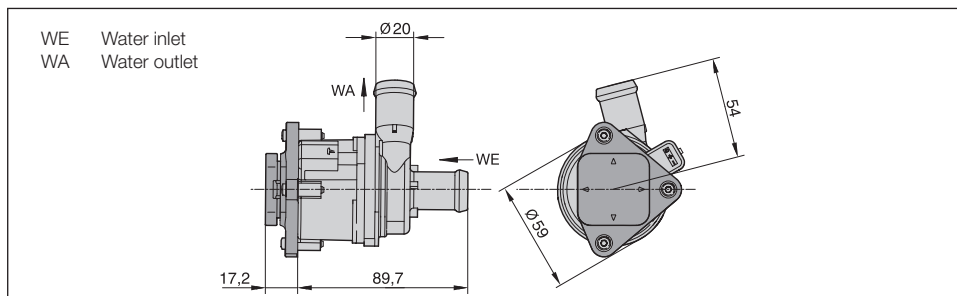



### 3 Installation

#### Installation location

The heater and the water pump are installed in the engine compartment.

The heater and the water pump must be installed below the min. cooling water level (header tank, radiator, vehicle's heat exchanger) so that the heat exchanger of the heater and water pump can independently vent.

#### Please note!

- Note and observe the relevant regulations and safety instructions given on pages 4 – 7.
- The positions suggested in the installation instructions are examples.

Other installation locations are possible if they comply with the installation requirements stated in these installation instructions.

- Further installation information (e.g. for boats and ships) is available from the manufacturer on request.
- Note and observe the permissible installation positions and operating and storage temperatures.
- Ensure adequate distance from hot vehicle parts.
- Do not install the water pump at the lowest point in the water circuit, as otherwise the particles in the water circuit settle in the water pump. A water filter must be used if the cooling water is highly soiled/contaminated with particles.

#### Installation example Heater in a car

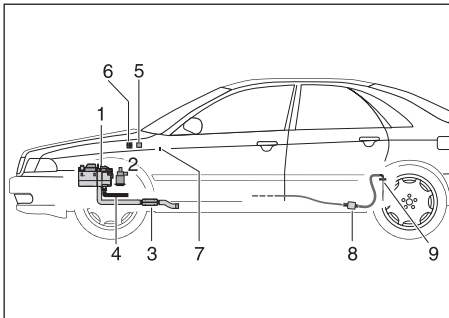

- 1 Heater
- 2 Water pump
- 3 Exhaust pipe with exhaust silencer
- 4 Combustion air hose
- 5 Blower relay
- 6 Fuse bracket
- 7 Control unit
- 8 Metering pump
- 9 Tank extractor

#### Installation example Heater in a transporter

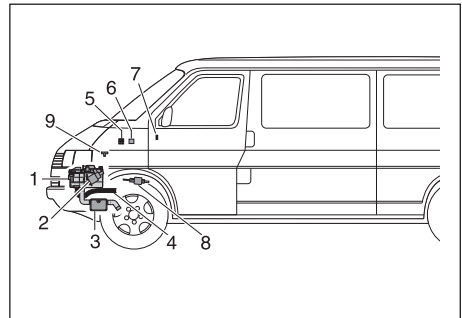

- 1 Heater
- 2 Water pump
- 3 Exhaust pipe with exhaust silencer
- 4 Combustion air hose
- 5 Fuse bracket
- 6 Blower relay
- 7 Control unit
- 8 Metering pump
- 9 T-piece for fuel

## 3 Installation

### Permissible installation positions

The heater and the water pump should preferably be installed in the normal position. Depending on the installation conditions, the heater can be installed within the permissible swivel ranges, see sketch.

#### Installation position – Heater horizontal / vertical

##### Heater for petrol and diesel

The horizontal installation position (normal position\*) with swivel range up to the vertical installation position is permitted.

All installation positions between 0° and 90° are permitted.

##### Heater for petrol with an addition of ethanol fuel >10%

The horizontal installation position (normal position\*) and the vertical installation position are permitted.

All installation positions between 0° and 90° are not permitted.

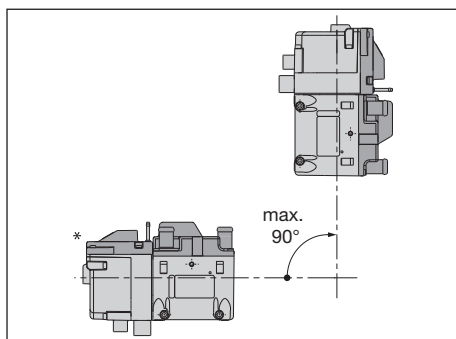

#### Water pump

The water pump can be installed in any position.

The water inlet must be designed so that it is always completely filled with water (the water pump is not self-priming).

#### Please note!

The installation position of the water pump with the pump head facing downwards is not advantageous for automatic venting.

#### Please note!

In heating mode, the normal and maximum installation positions shown can differ by up to +15° in all directions for a short time.

These differences, caused by tilted positions of the vehicle, do not have any negative effects on the heater's function.

#### Installation position – heater lying on its side / upright

##### Heater for petrol and diesel

The upright installation position (normal position\*) with swivel range through to the horizontal installation position is permitted.

All installation positions between 0° and 90° are permitted.

#### Please note!

If a heater is swivelled out of the normal position, the fuel connections must **always** be at the bottom.

##### Heater for petrol with an addition of ethanol fuel >10%

The upright installation position (normal position) is permissible.

The installation position with the heater lying on its side and installation positions between 0° and 90° are not permitted.

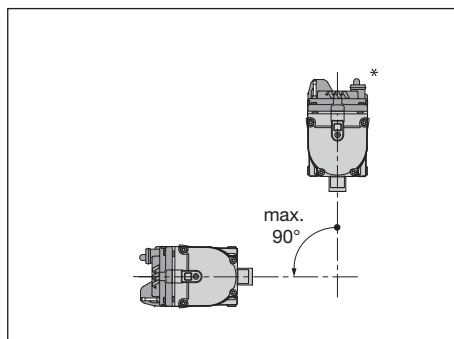





### 3 Installation

#### Installation and fixing – water pump

Fix the water pump bracket included in the installation kit to the heater (see installation examples below, tightening torque 6<sup>+2</sup> Nm) or in a suitable position within the vehicle, depending on the installation conditions. Then insert the water pump in the rubber element and press in until the water pump has latched into position.

#### Installation examples

Heater with angled water inlet connection. The water pump is fixed to the bottom of the heater, on the "fuel connection" side. The water discharge connection of the water pump faces to the side.

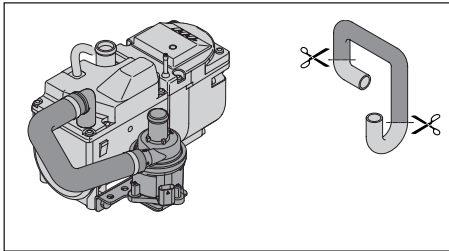

To install the water pump on the heater, use the universal water hose, Order No. 25 2526 80 01 02, described in the product information, and shorten its length as required.

Use the hose clips to fix the water hose.

Heater with angled water inlet connection. The water pump is fixed to the bottom of the heater, on the "water outlet connection" side. The water discharge connection of the water pump faces to the side.

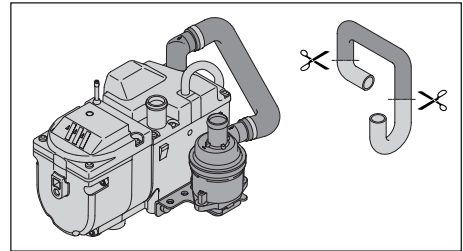

The water pump is fixed to the "fuel connection" side of the heater with rising water inlet connection. The water discharge connection of the water pump faces upwards.

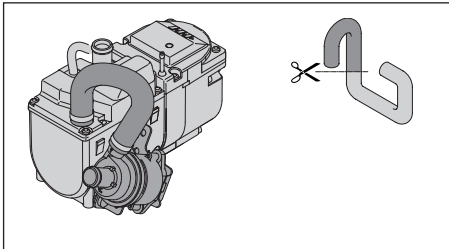

The water pump is fixed to the "water outlet connection" side of the heater with rising water inlet connection. The water discharge connection of the water pump faces upwards.

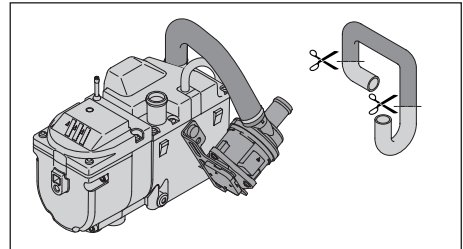

The water pump is fixed to the "fuel connection" side of the heater with the water inlet connection facing downwards. The water discharge connection of the water pump faces upwards.

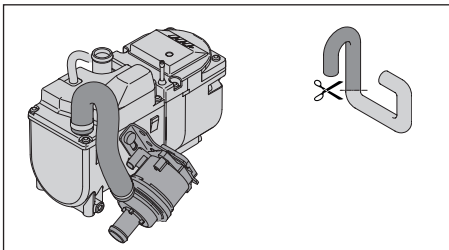

The water pump is fixed to the "water discharge connection" side of the heater with the water inlet connection facing downwards. The water discharge connection of the water pump faces upwards.

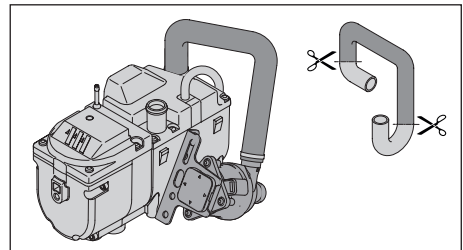

### 3 Installation

#### Installation and fixing – heater

Use the bracket included in the installation kit to fix the heater in a suitable position on the vehicle.

#### Installation steps

1. Use hexagon screws size M6 x 12 and hexagon nuts size M6 or self-tapping screws to fix the bracket.

Fixing with 3 screws or fixing with 4 screws.

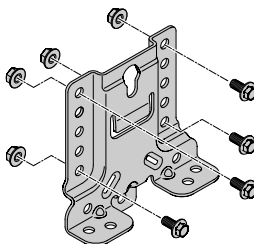
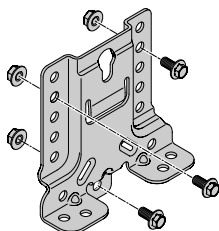

2. Mount special screw M6 x 17 onto the heater.

Mount special screw M6 x 17 (with adhesive coating) on heater on the fuel connection side (left-hand Fig.) or on the water discharge connection side (right-hand Fig.) (tightening torque  $6^{+2}$  Nm).

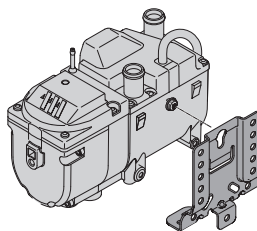
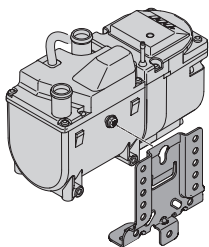

3. Hook heater into the bracket

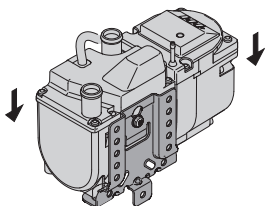

4. Use 2 hexagon screws M6 x 12 (with adhesive coating) to fix heater to the bracket (tightening torque  $6^{+2}$  Nm).

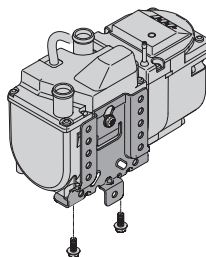



### 3 Installation

#### Installation of the angled water pipe sockets

The heater is supplied with straight water pipe sockets. Depending on the installation conditions, it may be necessary to install angled water pipe sockets.

##### Installation steps

- Undo the fixing screws in the cover and remove the cover.
- Push straight water pipe socket downwards.
- Loosen toothed ring and remove O-ring.
- Pull water pipe socket out of the cover.
- Insert angled water pipe socket in the cover, insert new O-ring in the groove provided.
- Fit toothed ring to the angled water pipe socket, turn water pipe socket according to installation position and insert in the sprocket of the cover.
- Use four screws to screw cover back onto the housing – tightening torque  $2.9^{+0.3}$  Nm.

If the angled water pipe socket conceals the screw opening used to date, the screw hole next to it must be used as an alternative.

If so, do so as follows:

- A thread must be cut first in the hole of the aluminium housing – to do this, screw one of the self-tapping screws into the hose and then unscrew again.
- Attach the cover and screw in all four screws – tightening torque  $2.9^{+0.3}$  Nm.

##### Please note!

The thread must be cut before mounting the cover.

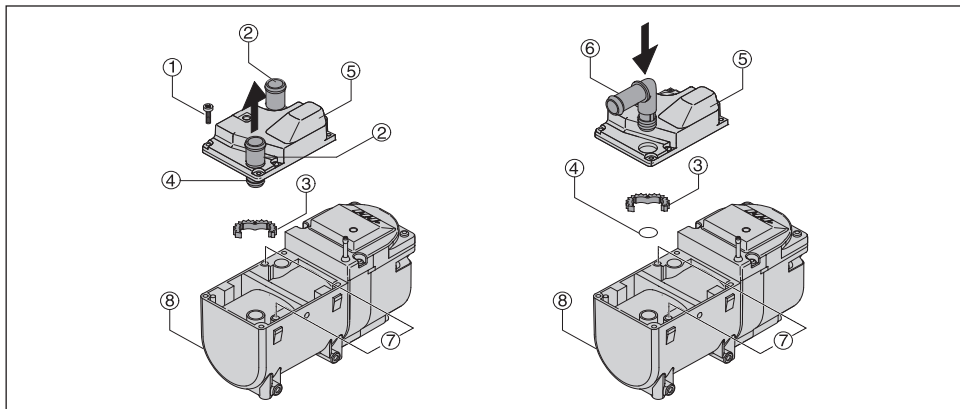

- 1 Fixing screws
- 2 Straight pipe socket
- 3 Toothed ring
- 4 O-ring

- 5 Cover
- 6 Angled pipe socket
- 7 Drill holes
- 8 Heater

#### Nameplate

The nameplate is fastened to the water jacket of the heater.

The 2nd nameplate (duplicate) is detachable, and is attached to the side of the heater. If required, the duplicate nameplate can be adhered in a clearly visible position on the heater or near to the heater.

##### Please note!

Note and observe the relevant regulations on page 5.

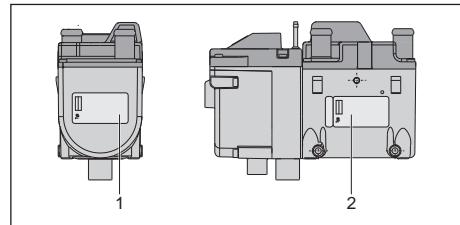

- 1 Nameplate
- 2 2nd nameplate (duplicate)

## 3 Installation

### Fix fuse holder and relay socket

Use a hexagon screw size M6 x 12 and hexagon nut size M6 to fix the bracket in a suitable position within the vehicle's engine compartment. Fix the fuse holder to the bracket using 2 blind rivets 4 x 8; to do this, press in the bolts of the two blind rivets until the fuse holder sits securely on the bracket. Use a blind rivet 5.5 x 12 to fix the relay socket to the bracket; to do this, press in the bolt of the blind rivet until the relay socket sits securely on the bracket.

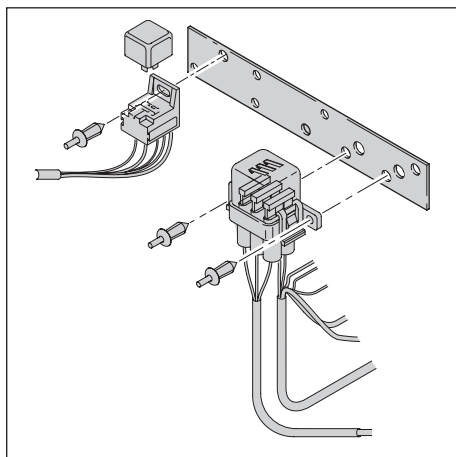

### Connection to the cooling water circuit

The heater and the water pump are integrated in the cooling water circuit in the water flow hose from the vehicle engine to the heat exchanger. There are four installation options for this. The installation options are described on pages 21 – 23.



#### **Danger!**

#### **Risk of injuries and burns!**

The coolant and components of the coolant circuit get very hot.

- Parts conveying water must be routed and fastened in such a way that they pose no temperature risk to man, animals or material sensitive to temperature from radiation / direct contact.
- Before working on the cooling water circuit, switch the heater off and wait until all the components have cooled down completely, if necessary wear protective gloves.

#### **Please note!**

- When installing the heater and the water pump, please note the direction of flow of the cooling water circuit.
- Fill the heater and water hose with coolant before connecting to the coolant circuit.
- Route the water hoses without any kinks, and in a rising position if possible.
- When routing the water pipes, maintain sufficient clearance from hot vehicle parts.
- Protect all water hoses / water pipes from chafing and from extreme temperatures.
- Secure all hose connections with hose clips (tightening torque: 3<sup>+0.5</sup> Nm).
- Re-tighten the hose clips after the vehicle has been running for 2 hours or has travelled 100 km.
- The minimum water flow rate is only guaranteed if the temperature difference of the heating medium does not exceed 10 K between water inlet and water outlet during heating.
- Only overpressure valves with an opening pressure of min. 0.4 – max. 2 bar may be used in the cooling water circuit.
- As corrosion protection the cooling water must contain at least 10 % coolant (anti-freeze).
- During cold periods the coolant water must contain sufficient coolant (antifreeze).
- Before commissioning the heater for the first time or after changing the cooling water, the whole cooling water circuit including the heater must be vented without bubbles according to the vehicle manufacturer's instructions.
- Only top up with coolant approved by the vehicle manufacturer.



### 3 Installation

#### Connection to the cooling water circuit

##### Integrate heater and water pump in the water flow hose from the vehicle engine to the heat exchanger – “inline connection”

Cut the water flow hose from the vehicle engine to the vehicle's heat exchanger.  
 Use connectors and water hoses to connect the heater and the water pump to the water flow hose.  
 Lay a water hose from the discharge end of the water pump to the water inlet socket of the heater and connect.

##### Heating characteristics

If the heater is switched on, the heat is initially fed via the heater's own heat exchanger to the vehicle's engine only. After the cooling water has reached a temperature of approx. 30 °C – depends on the selected blower setting – the vehicle blower switches on and the heat is then also fed to the passenger compartment.

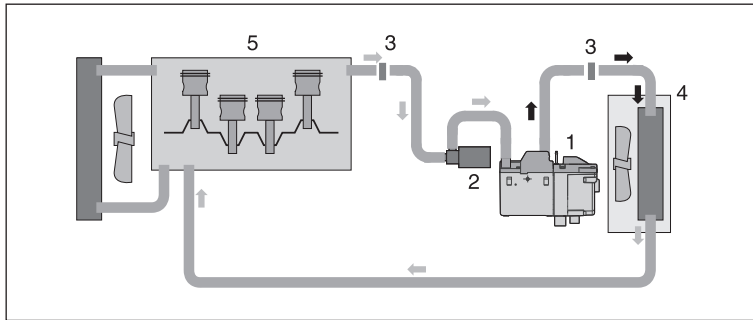

- 1 Heater
- 2 Water pump
- 3 Connector
- 4 Heat exchanger
- 5 Vehicle engine

##### Integrate the heater, water pump and non-return valve in the cooling water circuit

Cut the water flow hose from the vehicle engine to the vehicle's heat exchanger and insert the non-return valve.

Use water hoses to connect the heater and the water pump to the non-return valve. Lay a water hose from the discharge end of the water pump to the water inlet socket of the heater and connect.

##### Heating characteristics

If the heater is switched on, the heat is initially fed via the heater's own heat exchanger to the vehicle's engine only. After the cooling water has reached a temperature of approx. 30 °C – depends on the selected blower setting – the vehicle blower switches on and the heat is then also fed to the passenger compartment.

##### Advantage of the “inline connection” water circuit

No loss of vehicle heating effectiveness if heater is switched off.

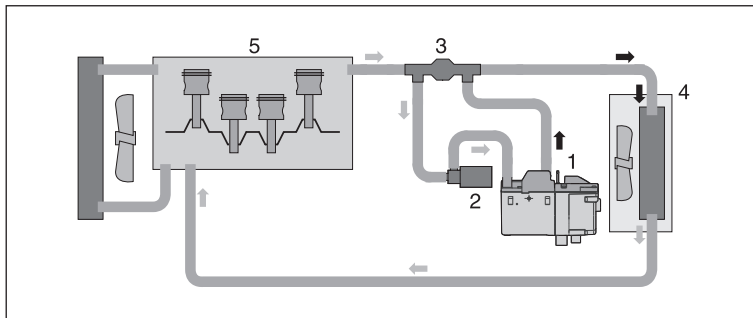

#### Please note!

Non-return valve must be ordered separately, refer to the product information for the Order No.

- 1 Heater
- 2 Water pump
- 3 Non-return valve
- 4 Heat exchanger
- 5 Vehicle engine

### 3 Installation

#### Connection to the cooling water circuit

##### Integrate the heater, water pump, non-return valve, thermostat and T-piece in the cooling water circuit

Cut the water flow hose from the vehicle engine to the vehicle's heat exchanger and insert the non-return valve.

Cut the water return hose from the vehicle's heat exchanger to the vehicle engine and insert the T-piece. Use water hoses to connect the heater and water pump to the thermostat, the non-return valve and T-piece – as shown in the sketch.

##### Heating characteristics

###### Small cooling water circuit

Initially, up to a cooling water temperature of approx. 70 °C, the heater's heat is fed to the vehicle's heat exchanger only – fast heating of the inside of the vehicle.

###### Large cooling water circuit

If the cooling water temperature continues to rise, the thermostat slowly switches over to the large circuit (full switchover is reached at approx. 75 °C) – heating of the inside of the vehicle and additional engine pre-heating.

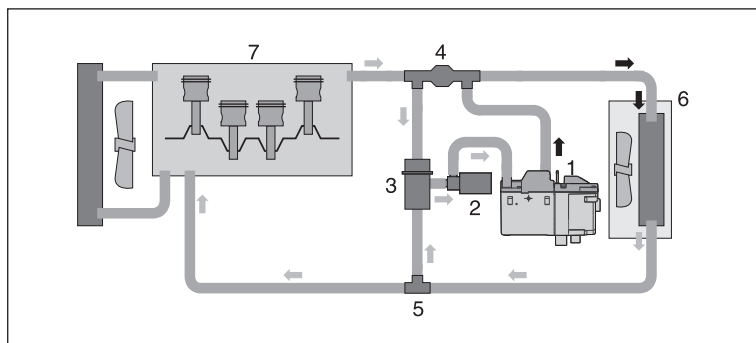

- 1 Heater
- 2 Water pump
- 3 Thermostat
- 4 Non-return valve
- 5 T-piece
- 6 Heat exchanger
- 7 Vehicle engine

#### Please note!

The thermostat, non-return valve and T-piece must be ordered separately, refer to the product information for the Order No.

#### Function of the thermostat

At a cooling water temperature < 70 °C – small cooling water circuit:

- Socket 1 – open (to the heater)
- Socket 2 – open (to the T-piece)
- Socket 3 – closed (to the non-return valve)

At a cooling water temperature > 75 °C – large cooling water circuit:

- Socket 1 – open (to the heater)
- Socket 2 – closed (to the T-piece)
- Socket 3 – open (to the non-return valve)

#### Please note!

Use the connections Item (1), (2) and (3) – as shown in the sketch – to integrate the thermostat in the cooling water circuit.

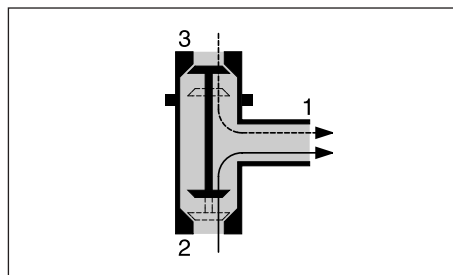

- 1 Socket, to the heater
- 2 Socket, to the T-piece
- 3 Socket, to the non-return valve



### 3 Installation

#### Connection to the cooling water circuit

**Integrate the heater, water pump and combination valve with thermostat function in the cooling water circuit**

**Using the combination valve with 5 connections**

If the water flow line and water return line from the vehicle engine to the heat exchanger are laid separately in the engine compartment, the combination valve with 5 connections and an additional T-piece must be used.

**Using the combination valve with 6 connections**

If the water flow line and water return line from the vehicle engine to the heat exchanger are laid in parallel in the engine compartment, the combination valve with 6 connections (without T-piece) must be used.

**Heating characteristic in parking heater mode – small cooling water circuit**

Initially, up to a cooling water temperature of approx. 67 °C, the heater's heat is fed to the vehicle's heat exchanger only – fast heating of the inside of the vehicle.

From a cooling water temperature of approx 67 °C, part of the heater's heat is also passed to the vehicle's engine. This causes additional engine pre-heating, without rapid cooling of the "small cooling water circuit" for interior heating.

**Heating characteristic in auxiliary heater mode – large cooling water circuit**

While the vehicle's engine is running the heat is uniformly distributed between the vehicle's heat exchanger and the vehicle engine – further shortening of the heating up phase and heating of the inside of the vehicle.

#### Install combination valve with 5 connections

Cut the water flow hose from the vehicle engine to the vehicle's heat exchanger and insert the combination valve.

Cut the water return hose from the vehicle's heat exchanger to the vehicle engine and insert the T-piece.

Use water hoses to connect the heater and water pump to the combination valve and and T-piece – as shown in the sketch.

#### Install combination valve with 6 connections

Cut the water flow hose and the water return hose from the vehicle engine to the vehicle's heat exchanger and insert the combination valve.

Use water hoses to connect the heater and water pump to the combination valve – as shown in the sketch.

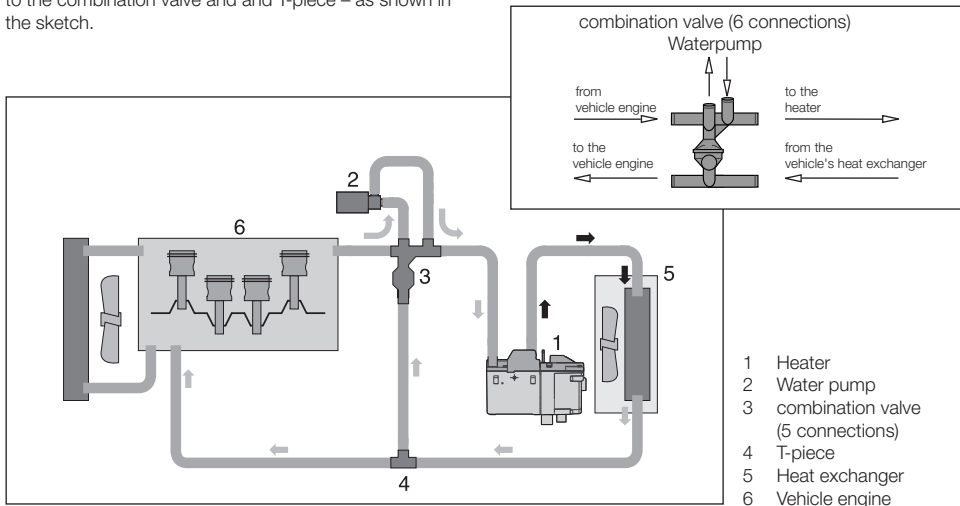

## 3 Installation

### Exhaust system

The complete exhaust system to be installed is included in the scope of supply of the universal installation kit. The exhaust system consists of a flexible exhaust pipe, inner Ø 24 mm, 900 mm long, a flexible exhaust pipe end with end sleeve, inner Ø 24 mm, 300 mm long and an exhaust silencer.

If necessary, the flexible exhaust pipe and the flexible exhaust pipe end can be shortened or lengthened according to the installation conditions (see Fig. page 25). Please refer to the additional parts catalogue for details of parts for extending the exhaust system.

### Mounting the exhaust system

Use a bracket included in the universal installation kit (L bracket or Z bracket) to fix the exhaust silencer in a suitable position on the vehicle (see sketch on page 25).

Lay the flexible exhaust pipe from the heater to the exhaust silencer and fasten with pipe clips (tightening torque:  $7^{+0.5}$  Nm), adjust the length if necessary.

If necessary, shorten the exhaust pipe end with end sleeve, push onto the exhaust silencer and fix with a pipe clip (tightening torque:  $7^{+0.5}$  Nm).

If necessary, use pipe clips to fasten the flexible exhaust pipe and the exhaust pipe end in suitable positions in the vehicle.

If necessary, attach spacer rings to the flexible exhaust pipe and to the exhaust pipe end.

- Exhaust pipes must be securely fixed (recommended clearance of 50 cm) to avoid damage due to vibrations.
- Lay the exhaust system so that the outflowing exhaust gases are not sucked in as combustion air.
- The mouth of the exhaust pipe must not become clogged with dirt and snow.
- The mouth of the exhaust pipe must not point in the direction of travel.
- Always fix the exhaust silencer to the vehicle.
- Lay the exhaust system so that the exhaust fumes do not flow directly onto heat-sensitive components.



### Danger!

#### Risk of injuries and burns!

Every type of combustion produces high temperatures and toxic exhaust fumes. This is why the exhaust system must be routed according to these installation instructions.

- Do not perform any work on the exhaust system while the heater is working.
- Before working on the exhaust system, switch off the heater first and wait until all the parts have completely cooled down, wear safety gloves if necessary.
- Do not inhale exhaust fumes.

#### Please note!

- Comply with the regulations and safety instructions for this chapter given on page 4 – 7.
- The exhaust pipe end should be much shorter than the flexible exhaust pipe from the heater to the exhaust silencer.



### Caution!

#### Safety instructions!

The whole exhaust system gets very hot while the heater is running and immediately afterwards. This is why the exhaust system must be routed according to these installation instructions.

- The exhaust pipe must end in the open air.
- The exhaust pipe may not protrude beyond the lateral limits of the vehicle.
- Install the exhaust pipe sloping slightly downwards. If necessary, make a drain hole with approx. Ø 5 mm at the lowest point as a condensation outlet.
- Important functional parts of the vehicle may not be impaired (maintain sufficient clearance).
- Mount the exhaust pipe with sufficient clearance to heat-sensitive parts. Pay particular attention to fuel pipes (made of plastic or metal), electrical cables and brake hoses, etc.!





### 3 Installation

#### Combustion air system

##### Installing the combustion air system

The combustion air must be drawn out of an area which does not become hotter than 25 °C and in which neither spray water or dust / dirt are to be expected.

The flexible combustion air hose included in the universal installation kit (double-walled, sound insulating), inner Ø 20 mm, 760 mm long, must be installed with a hose clip (tightening torque 3<sup>+0.5</sup> Nm), in order to remove the combustion air from an area, which fulfils the conditions named above.

If necessary, the flexible combustion air hose can be shortened according to the installation conditions.

When shortening the combustion air hose, ensure the cutting edge is clean, small cut-off pieces could block the combustion air fan.

#### Please note!

Comply with the regulations and safety instructions for this chapter given on page 4 – 7.



#### Caution!

##### Safety instructions for the combustion air system

- The combustion air opening must be free at all times.
- Lay the combustion air intake to ensure that exhaust fumes cannot be sucked in as combustion air.
- Arrange the combustion air intake so that it is not directed against the wind blast or airstream.
- The combustion air intake must not become clogged with dirt and snow.
- Install the combustion air intake system sloping slightly downwards. If necessary, make a drain hole approx. Ø 5 mm at the lowest point to drain off condensation.

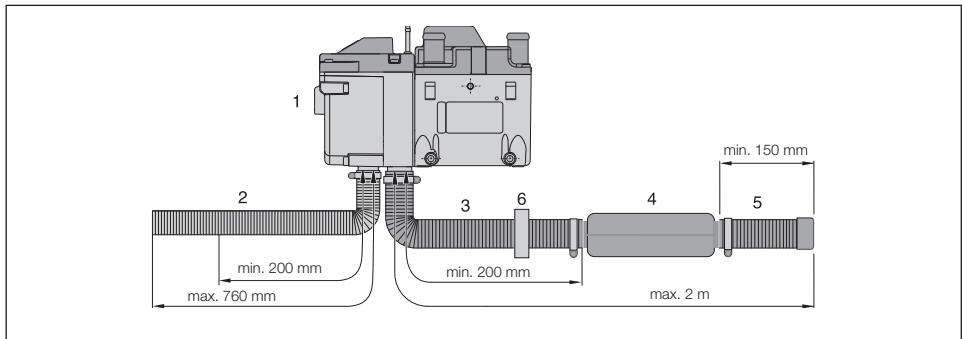

1 Heater

2 Combustion air hose

3 Flexible exhaust pipe

4 Exhaust silencer

5 Exhaust pipe end with end sleeve

6 Spacer ring

##### Fix bracket to exhaust silencer

Various options for fixing the L bracket to the exhaust silencer (tightening torque 6<sup>+0.5</sup> Nm)

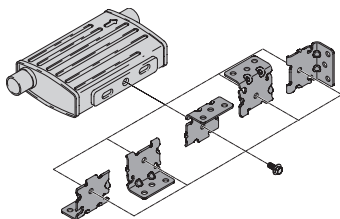

Various options for fixing the Z bracket to the exhaust silencer (tightening torque 6<sup>+0.5</sup> Nm)

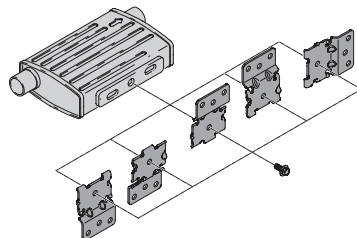

### 3 Installation

#### Fuel supply

##### Installing the metering pump, laying the fuel pipes and installing the fuel tank.

The following safety instructions must always be observed when installing the metering pump, laying the fuel pipes and installing the fuel tank.

Deviations from the instructions stated here are not allowed. Failure to comply can result in malfunctions.



#### Danger!

##### Risk of fire, explosion, poisoning and injuries!

Caution when handling fuel.

- Switch off the vehicle engine and the heater before refuelling and before working on the fuel supply.
- Avoid naked flames when handling fuel.
- Do not smoke.
- Do not inhale petrol fumes.
- Avoid any contact with the skin.



#### Caution!

##### Safety instructions for laying the fuel pipes!

- Use a sharp knife only to cut fuel hoses and pipes to length. Interfaces must not be crushed and must be free of burrs.
- The fuel pipe from the metering pump to the heater should be laid with a continuous rise.
- Fuel pipes must be securely fixed to avoid any damage and / or noise due to vibrations (recommended guideline value: of approx. 50 cm).
- Fuel pipes must be protected against mechanical damage.
- Route the fuel pipes so that any distortion of the vehicle, engine movements etc. cannot have any lasting effect on the service life.
- Use hose clips to secure all hose connections in the fuel supply (tightening torque 1<sup>+0.2</sup> Nm)

- Parts carrying fuel must be protected from interfering heat.
- Never route or fasten the fuel pipes to the heater or vehicle exhaust system.  
When systems cross, always ensure there is a sufficient heat clearance. If necessary, attach heat deflection plates.
- Dripping or evaporating fuel must never be allowed to collect on hot parts or ignite on electric systems.
- When connecting fuel pipes with a fuel hose, always mount the fuel pipes in a butt joint to prevent any bubbles from forming.

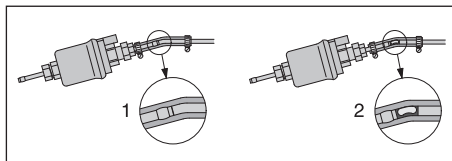

- 1 Correctly laid lines
- 2 Incorrectly laid lines – bubbles form



#### Caution

##### Safety instructions for fuel pipes and fuel tanks in buses and coaches

- In buses and coaches, fuel pipes and fuel tanks must not be routed through the passenger compartment or driver's cab.
- Fuel tanks in buses and coaches must be positioned in such a way that the exits are not in immediate danger if a fire occurs.

#### Please note!

Comply with the regulations and safety instructions for this chapter given on page 4 – 7.



### 3 Installation

#### Fuel supply

Preferred fuel extraction with tank connection or with adapter  
– in petrol and diesel vehicles

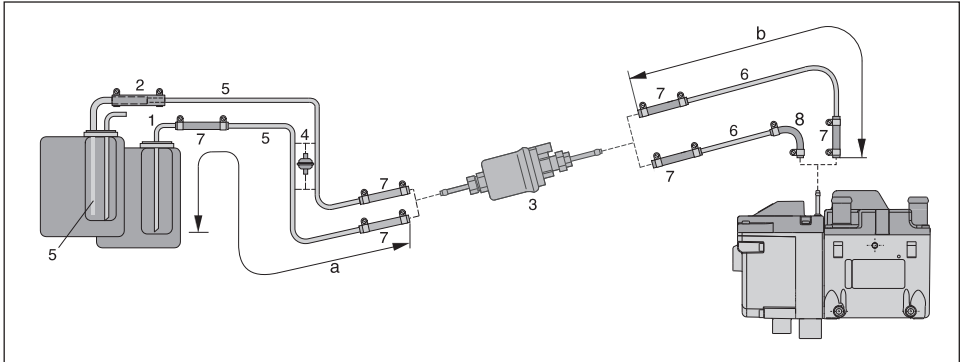

- 1 Tank connection,  $d_i = \varnothing 2 \text{ mm}$ ,  $d_a = \varnothing 4 \text{ mm}$  – installed in the vehicle's own tank fitting
- 2 Adapter,  $\varnothing 7.5 / 3.5 \text{ mm}$  – connected to the vehicle's own tank fitting at a pipe socket  $\varnothing 8 \text{ mm}$  used to pass through the intake line (fuel pipe  $4 \times 1$ ) up to just before the bottom of the tank.
- 3 Metering pump
- 4 Fuel filter – required for contaminated fuel only
- 5 Fuel pipe,  $4 \times 1$  ( $d_i = \varnothing 2 \text{ mm}$ , blue)
- 6 Fuel pipe,  $4 \times 1.25$  ( $d_i = \varnothing 1.5 \text{ mm}$ , transparent)
- 7 Fuel hose,  $3.5 \times 3$  ( $d_i = \varnothing 3.5 \text{ mm}$ ), approx. 50 mm long
- 8 Elbow,  $105^\circ$

#### Permissible pipe lengths

**Intake side**  
a = max. 2 m

**Pressure side**  
b = max. 6 m



#### Caution!

#### Safety instructions for the fuel supply!

The fuel must not be discharged by means of gravity or overpressure in the fuel container.

#### Please note!

- Item (4) is not included in the "Universal installation kit" scope of supply.  
Refer to the product information for the Order No.
- Installation of the fuel filter Item (4) requires two adapters  $\varnothing 5 / 3.5$ , Order No. 25 1888 80 01 02.
- Use two hose clips  $\varnothing 11$  to secure the adapter  $\varnothing 7.5 / 3.5 \text{ mm}$ , Item (2).

### 3 Installation

**Fuel supply – only for diesel vehicles and heaters with inlet pressure resistant metering pump up to 2.0 bar.**

**Fuel extraction using T-piece from the fuel return line laid between the vehicle engine and the tank fitting**

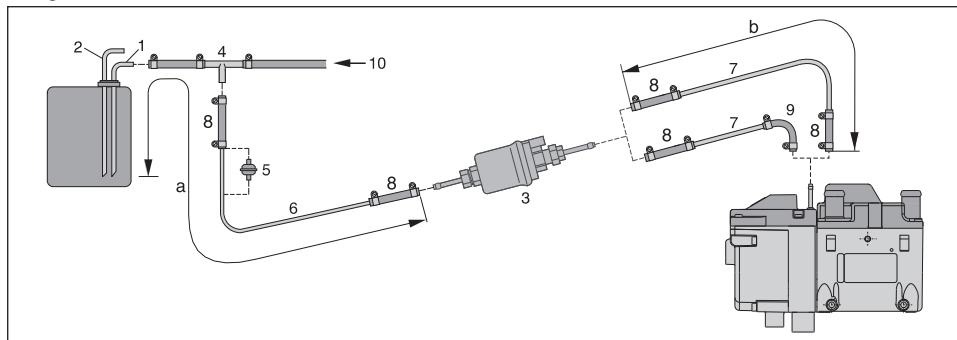

- 1 Fuel return line from the vehicle's own tank fitting
- 2 Fuel flow line from the vehicle's own tank fitting
- 3 Metering pump (inlet pressure resistant up to 2.0 bar) identified with a green nameplate
- 4 T-piece
- 5 Fuel filter – required for contaminated fuel only
- 6 Fuel pipe, 4 x 1 (di = Ø 2 mm, blue)
- 7 Fuel pipe, 4 x 1.25 (di = Ø 1.5 mm, transparent)
- 8 Fuel hose, 3.5 x 3 (di = Ø 3.5 mm) approx. 50 mm long
- 9 Elbow, 105°
- 10 from the vehicle engine to the tank fitting

- If the pressure in the fuel pipe is more than 2.0 bar up to max. 4.0 bar, use a pressure reducer (Order No. 22 1000 20 08 00) or a separate tank connection.
- If the pressure in the fuel pipe is over 4.0 bar or if there is a non-return valve in the return pipe (in the tank), a separate tank connection must be used.
- The vehicle must be delivered with an almost empty vehicle tank.
- After the fuel return line has been disconnected, with the vehicle engine stopped, it is necessary to check by suction whether fuel can be removed from the vehicle tank without air bubbles. This ensures that the fuel return line ends just before the floor of the tank and no non-return valve is installed. If this is not true, the fuel extraction connection must be made with a separate tank connection or with an adapter.

#### Permissible pipe lengths

##### Intake side

a = max. 2 m

##### Pressure side

b = max. 6 m

#### Please note!

Items 4 and 5 are not included in the "Universal installation kit" scope of supply. Refer to the product information for the Order No.

#### Caution!

##### Safety instructions for the fuel supply!

- It is not permitted to extract fuel downstream of the vehicle's own fuel pump.
- If using a T-piece in a plastic pipe, always insert support sleeves in the plastic pipe.
- Always insert the T piece in the fuel return line.
- Connect the T-piece and the plastic pipe with the relevant fuel hoses and secure with hose clips.

#### Installation position of the T-piece

Install any T-piece in the same installation positions shown in the diagram.

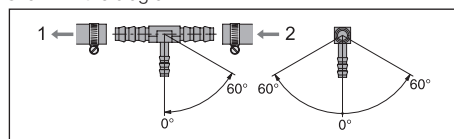

- 1 Direction of flow – to the fuel tank
- 2 Direction of flow – from the vehicle engine



## 3 Installation

### Fuel supply

#### Installation position of the metering pump

Always install the metering pump with the delivery side rising upwards.

Any mounting position over 15° is allowed, although a mounting position between 15° and 35° is preferable.

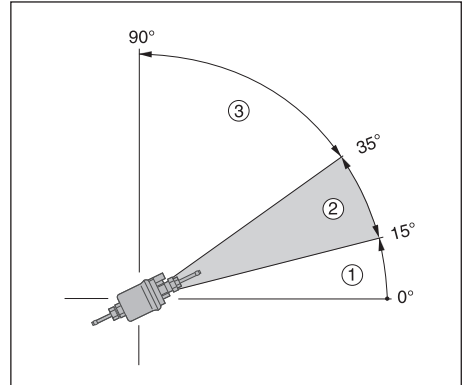

- 1 Installation position within range 0° – 15° is not allowed
- 2 Preferred installation position within range 15° – 35°
- 3 Installation position within range 35° – 90° is allowed

#### Permissible suction and pressure head of the metering pump

Pressure head from vehicle tank to metering pump:  
a = max. 3000 mm

Suction head in pressure-less vehicle tank:  
b = max. 500 mm for petrol  
b = max. 1000 mm for diesel

Suction head in a vehicle tank in which negative pressure occurs during extraction (valve with 0.03 bar in the tank cap):

b = max. 150 mm for petrol  
b = max. 400 mm for diesel

Pressure head from the metering pump to the heater:  
c = max. 2000 mm

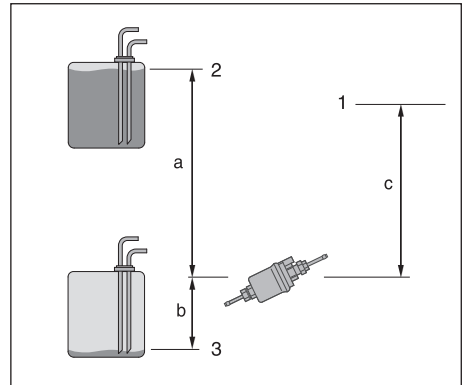

- 1 Connection at the heater
- 2 Max. fuel level
- 3 Min. fuel level

#### Please note!

Check tank ventilation.



#### Caution!

#### Safety instructions for installing the metering pump!

- Always install the metering pump with the delivery side rising upwards – minimum angle 15°.
- Protect the metering pump and filter from impermissible heating, do not install near to silencers and exhaust pipes.

## 3 Installation

---

### Fuel supply

#### Fuel quality for petrol heaters

- The heater runs problem-free on standard commercial quality fuel in accordance with EN 51600 and EN 228, which you use to run your vehicle engine.
- The Hydronic II, B 5 S heater can be run on ethanol E85.

#### Please note!

- If running the heater on ethanol E85, special suitable fuel hoses must be used, refer to the product information for the Order No.
- If running with ethanol E85, the heating output reduces by approx. 30 %.
- The Hydronic II, B 4 S heater is **not** approved for running on ethanol E85.

#### Fuel quality for diesel heater

- The heater runs problem-free on standard commercial grade diesel fuel according to DIN EN 590. During the winter months the diesel fuel is adapted to the low temperatures of 0 °C to -20 °C. This means that problems can only arise if extreme drops in temperature occur – as is the case for the vehicle engine too – please refer to the vehicle manufacturer's instructions.
- In special cases and at external temperatures above 0 °C, the heater can also run on EL heating oil to DIN 51603.
- If the heater is run from a separate tank, please comply with the following rules:
  - at external temperatures above 0 °C, use diesel fuel to EN 590;
  - at external temperatures of 0 °C to -20 °C, use winter diesel to EN 590;
  - at external temperatures of -20 °C to -40 °C, use Arctic diesel or polar diesel.

#### Please note!

- Additions of used oil are **not** allowed!
- After refuelling with winter or cold diesel, the fuel pipes and the metering pump must be filled with the new fuel by letting the heater run for 15 minutes!

#### Operation with biodiesel (FAME for diesel engines according to DIN EN 14 214)

The heater is **not** approved for running on biodiesel according to DIN EN 14214.



## 4 Operation and function

### Operating instructions

The heater is operated by a control unit. Detailed operating instructions are supplied with the control unit.

#### Please note!

You will be issued the operating instructions by the installation workshop.

### Important instructions for operation

#### Initial commissioning of the heater

The following points are to be checked by the company installing the heater during initial commissioning.

- Following installation of the heater, the cooling water circuit and the whole fuel supply system must be carefully vented. Comply with the instructions issued by the vehicle manufacturer.
- Open the coolant circuit before the trial run (set the temperature control to "WARM").
- During the heater trial run, all water and fuel connections must be checked for leaks and secure, tight fit.
- If faults occur while the heater is running, use a diagnostic unit to determine and correct the cause of the fault.

#### Safety checks before starting up the heater

After a lengthy stoppage (summer months), check all components for secure fit (tighten screws where necessary).

Carry out a visual check of the fuel system for leaks.

#### Before switching on

Before switching on or pre-programming heating mode, switch the vehicle's heating control to "WARM" (maximum setting) and the blower to "slow level" (low electricity consumption).

In vehicles with automatic heating, before switching off the ignition, switch the heating control to "MAX" and the required damper position to "OPEN".

#### Parking ventilation

Parking / cab ventilation means: possible activation of the vehicle blower directly via the control unit or – even more useful – via the radio remote control by bypassing heating mode, in order to ventilate the often over-heated vehicle interior with fresh air just before driving away.

### Functional description

#### Switching on (parking heater mode)

- **Parking heater mode**  
When the heater is switched on, the  symbol appears in the control unit.
- **Auxiliary heater mode**  
If the vehicle's engine is "ON" the heater starts simultaneously. An "auxiliary heating < 5 °C" switch can be installed as an option, i.e. auxiliary heating mode is only possible at an ambient temperature < 5 °C (for connection details, see circuit diagram on page 34).

#### Heating mode

The water pump starts up and, following a preset program sequence, the combustion air fan, glow plug and metering pump are started.

The time-controlled glow plug is switched off once a stable flame has formed in the combustion chamber.

Depending on the heat requirements, the heater runs at the following levels: Power – High – Low – Off (pause mode). The temperature thresholds for these are permanently programmed in the electronic control box.

The heater starts in "Power" control stage.

After the cooling water temperature has reached approx. 65 °C – depending on the selected blower setting – the heater switches to the "High" control stage.

If the cooling water continues to rise up to 80 °C, the heater switches to "Low" control stage.

- If the heat output achieved in "Low" control stage is insufficient, the cooling water temperature drops to 75 °C – the heater switches back to "High" control stage.
- If the heating output in "Low" control stage is inadequate, the cooling water temperature rises to 85 °C. The heater switches to "Off" control stage (pause mode) and is followed by an after-run,
  - of 120 seconds for petrol heaters,
  - of 90 seconds for diesel heaters.
- If the cooling water temperature cools to 75 °C during pause mode, a controlled start occurs in a high control stage.

The  symbol continues to be displayed during pause mode, the water pump is still running.

## 4 Operation and function

### Functional description

#### Heating at high altitudes

When using the heater at high altitudes, please note:

- Heating at altitudes up to 1500 m:
  - Unlimited heating possible.
- Heating at altitudes over 1500 m – 3000 m:
  - The heater can be run for short periods (e.g. driving through a mountain pass or taking a break in your journey).
  - During longer stays, e.g. winter camping, the fuel supply must be adjusted to the altitude. This can be done by installing an air pressure sensor. The air pressure sensor is included in the altitude kit – Order No. 22 1000 33 22 00.

#### Control and safety devices

- The heater is restarted if it does not ignite within a certain time, 100 seconds for petrol heaters and 70 seconds for diesel heaters. The heater is automatically shut down if, after three further start attempts in the case of a petrol heater and two attempts with a diesel heater, the petrol heater fails to start within the preset safety period (240 seconds). After an impermissible number of failed start attempts, the control box is locked.\*
- If the flame independently goes out during operation, the heater is restarted and if necessary, a maximum of two further start attempts are made within the preset safety time. If the heater does not ignite or ignites but goes out again within 15 minutes, a safety lock-out occurs. The safety lock-out can be cancelled by briefly switching off and on again (ignition ON/OFF).
- In the case of overheating (e.g. water shortage, poorly ventilated cooling water circuit), the overheating sensor triggers, the fuel feed is interrupted and the heater is automatically shut down. Once the cause of the overheating has been eliminated, the heater can be re-started by switching off and on again (ignition ON/OFF). Precondition: the heater has cooled down sufficiently, cooling water temperature < 70 °C. After an impermissible number of shut-downs on overheating, the control box is locked\*.
- If the lower or upper voltage limit is reached, the heater is automatically shut down.
- The heater does not start up if the glow plug is defective or if the electric cable to the metering pump is interrupted.

- The speed of the blower motor is continuously monitored. If the blower motor does not start up, if it is blocked or if the speed falls below 40 % of the desired speed, the heater is automatically shut down after 60 sec.
- \* Cancellation of the lock or reading out errors is possible:
  - using the EasyStart T timer
  - using the EasyStart R+ radio remote control.For other controls:
  - the diagnostic unit
  - the customer service program EDiTH.

For operation and fault list, please refer to the enclosed operating instructions or the troubleshooting and repair instructions for the heater.

#### Please note!

Do not repeat the switching off / on routine more than twice.

#### Emergency shutdown – EMERGENCY OFF

If an emergency shutdown – EMERGENCY OFF – is necessary during operation, proceed as follows:

- Switch the heater off at the control unit or
- remove the fuse or
- disconnect the heater from the battery.





## 5 Electric

### Heater wiring



#### Caution!

#### Safety instructions for wiring the heater!

The heater is to be connected up electrically according to the EMC directives. EMC can be affected if the heater is not connected up correctly. For this reason, comply with the following instructions:

- Ensure that the insulation of electrical cables is not damaged.  
Avoid:  
chafing, kinking, jamming or exposure to heat.
- Seal any connector chambers of watertight connectors not in use with filler plugs to ensure they are dirt-proof and water-proof.
- Electrical connections and ground connections must be free of corrosion and firmly connected.
- Lubricate connections and ground connections outside the heater interior with contact grease.

#### Please note!

Comply with the following when wiring the heater and the control unit:

- Electrical leads and components must be positioned in the vehicle so that they can function perfectly under normal operating conditions without impairment (e.g. due to heat exposure, moisture, etc.).
- The following cable cross section is to be used between the battery and heater.  
This ensures that the max. permissible voltage drop in the cables does not exceed 0.5 V for 12 V rated voltage.  
Cable cross-section for a cable length (plus cable + minus cable) up to 6 m = cable cross-section 4 mm<sup>2</sup>.
- If the positive cable is to be connected to the fuse box (e.g. terminal 30), the vehicle's cable from the battery to the fuse box must also be included in the calculation for the total cable length and re-dimensioned if necessary.
- Insulate unused cable ends.

#### Cable colours

rt = red	gn = green	br = brown
bl = blue	gr = grey	li = purple
ws = white	ge = yellow	
sw = black	vi = violet	

Connectors and bush housings are shown from the cable inlet side.

### Parts list for heater circuit diagram

#### Parts list

- |       |   |
|-------|---|
| 1.1   | Burner motor  |
| 1.2   | Glow plug   |
| 1.5   | Control – overheating sensor                            |
| 1.12  | Flame sensor  |
| 1.13  | Surface sensor  |
| 2.1   | Control box   |
| 2.2   | Fuel metering pump                                      |
| 2.5.7 | Vehicle blower relay                                    |
| 2.7   | Main fuse, 20 A   |
| 2.7.1 | Activation fuse, 5 A                                    |
| 2.7.5 | Vehicle blower fuse, 25 A                               |
| 2.12  | Water pump  |
| 5.1   | Battery   |
| a)    | For auxiliary heating criterion, connect to D+ (option) |
| b)    | Vehicle blower connection                               |
| g)    | For S heater  |
| h)    | For SC heater   |
| k)    | "Auxiliary heating" < 5 °C switch                       |
| k)    | Temperature switch (< 5 °C)                             |

#### Please note!

- The relay, 12 volt 2.5.7 (from terminal 30 to terminal 87a) has a maximum power consumption of 40 A; i.e. the value of the vehicle's own blower fuse may not be more than 40 A. See page 33 for circuit diagram.
- The circuit diagrams for the EasyStart Timer, Remote, Remote+ and Select control units are given in the installation instructions of the control unit and in the Installation Instructions Plus, which can be viewed and downloaded from the Service Portal.

#### Assignment of connector S1

Chamber	Cross-section	Colour	Function
1	2.5	red	Battery "Plus" (Terminal 30)
2	2.5	brown	Battery "Minus" (Terminal 31)
3	0.5	black/red	Vehicle fan
4	1.0	green	Metering pump "Plus"
5	0.5	blue/white	JE diagnosis
6	0.5	blue	Auxiliary heating criterion
7	0.5	yellow	Switch on "Plus"
8	0.5	violet	Water pump "Plus"
9	1.0	brown	Water pump "Minus"
10	1.0	brown/green	Metering pump "Minus"

# 5 Electric

## Heater circuit diagram

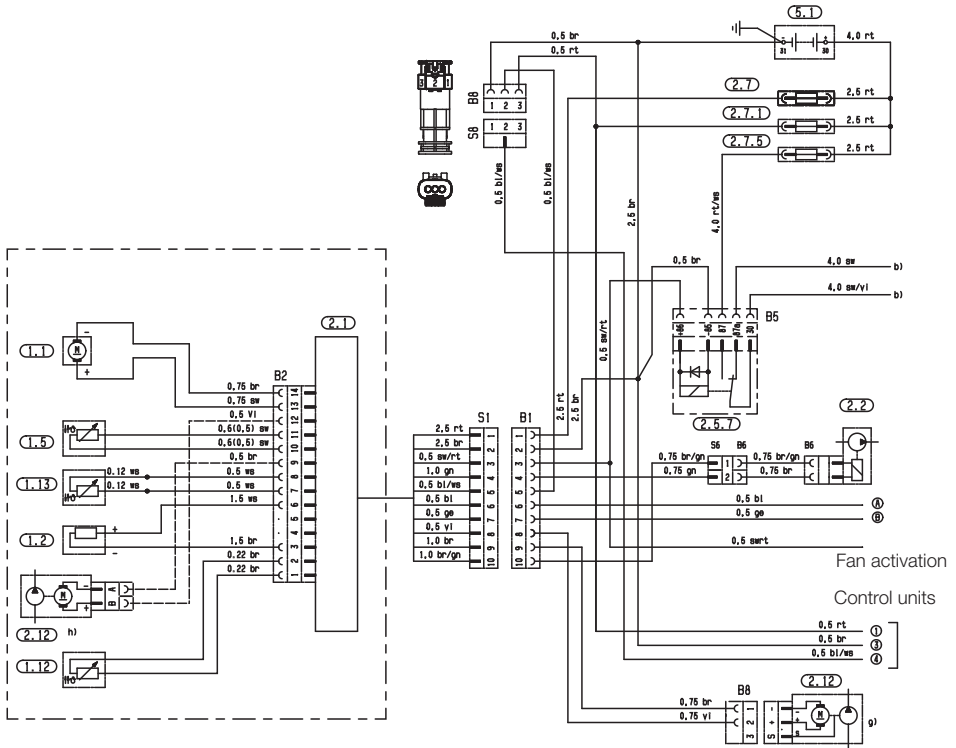

### CONNECTION DIAGRAM FOR THE AUXILIARY HEATING FUNCTION

Variant 1: For EasyStart control units

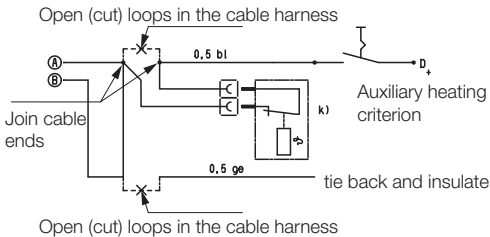

Variant 2: All control units except EasyStart

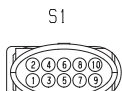
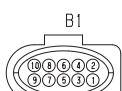
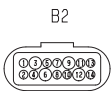
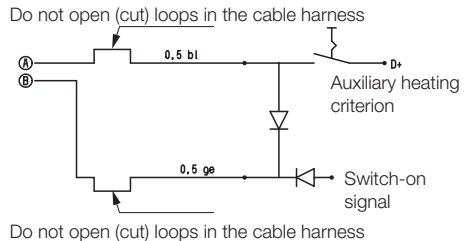

See page 32 for parts list.

25 2526 00 96 01

# 5 Electric



## Circuit diagram control unit – EasyStart R<sup>+</sup>

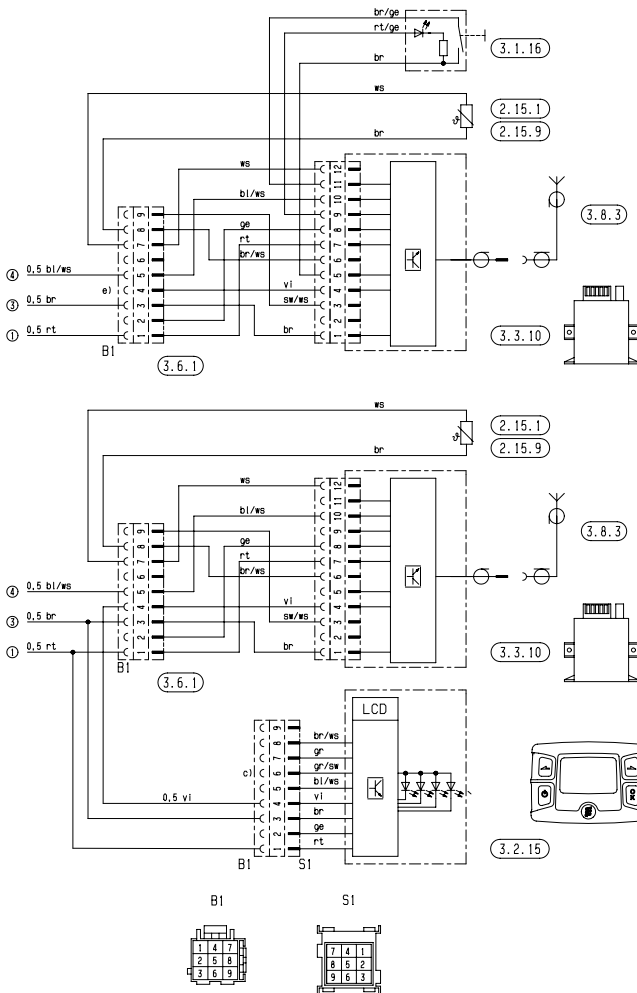

25 2281 00 97 01 A

### Parts list

- |        |  |       |   |
|--------|--|-------|---|
| 2.15.1 | Room temperature sensor                              | 3.6.1 | Lead harness  |
| 2.15.9 | Temperature sensor (outside temperature) (optional)  | 3.8.3 | Antenna   |
| 3.1.16 | Radio remote control button                          | c)    | Terminal 58 (lighting)  |
| 3.2.15 | Timer, EasyStart T                                   | e)    | Connection, EasyStart T timer                                     |
| 3.3.10 | Radio remote control, EasyStart R+ (stationary unit) |       | Connectors and bush housings are shown from the cable inlet side. |

## 5 Electric

### Circuit diagram control unit – EasyStart R

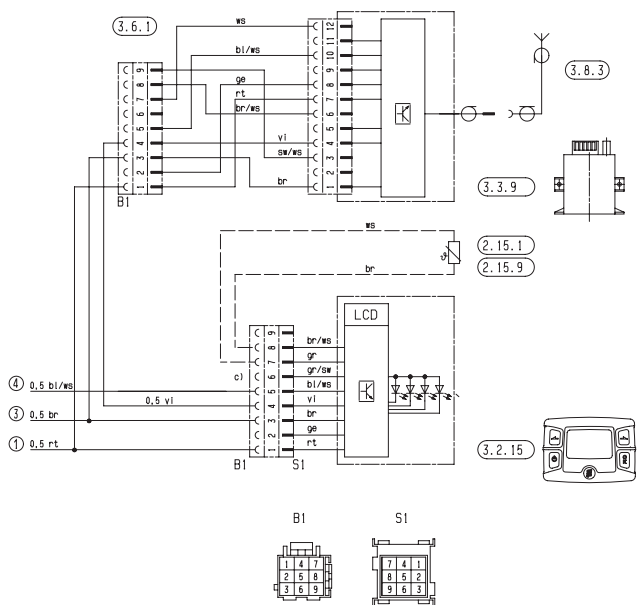
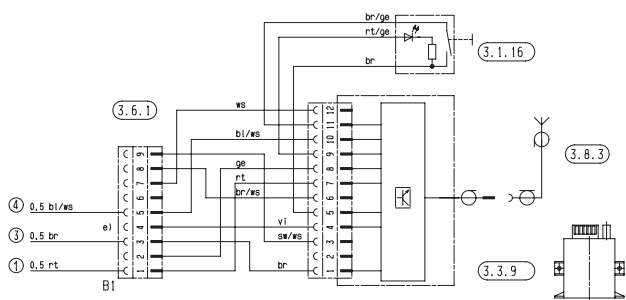

#### Parts list

- 2.15.1 Room temperature sensor (optional)
- 2.15.9 Temperature sensor (outside temperature) (optional)
- 3.1.16 Radio remote control button
- 3.2.15 Timer, EasyStart T
- 3.3.9 Radio remote control, EasyStart R (stationary unit)

- 3.6.1 Lead harness
- 3.8.3 Antenna
- c) Terminal 58 (lighting)
- e) Connection, EasyStart T timer

Connectors and bush housings are shown from the cable inlet side.

25 2281 00 97 02 A

# 5 Electric



## Circuit diagram control unit – EasyStart T

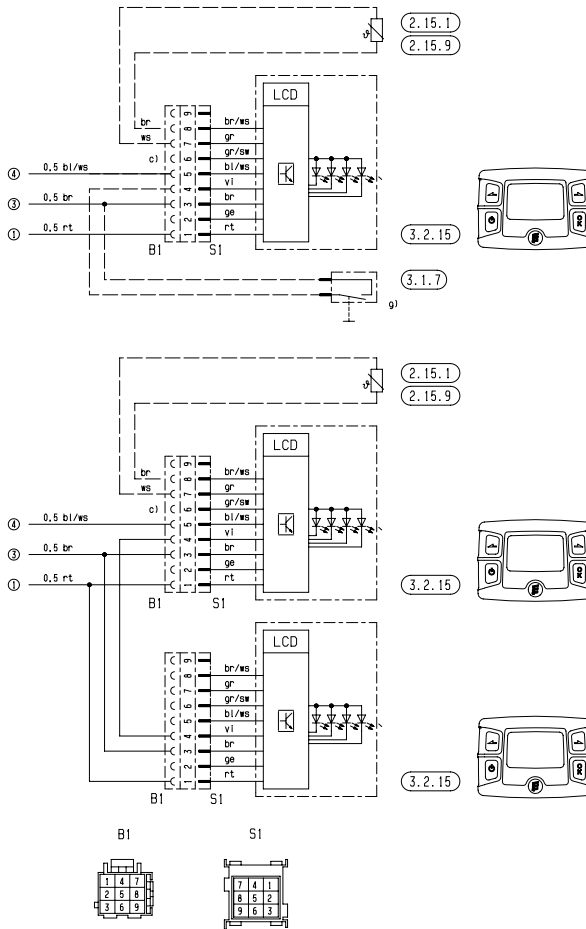

25 2281 00 97 03 A

### Parts list

- 2.15.1 Room temperature sensor (optional)
- 2.15.9 Temperature sensor (outside temperature) (optional)
- 3.1.7 "OFF" button
- 3.2.15 Timer, EasyStart T

- c) Terminal 58 (lighting)
- g) External "ON / OFF" button (optional)

Connectors and bush housings are shown from the cable inlet side.

## 6 Troubleshooting / maintenance / service

---

### If any faults occur, please check the following items

- If the heater does not start after being switched on:
  - Switch the heater off and on again.
- If the heater still does not start, check whether:
  - Fuel in the tank?
  - The fuses are ok?
  - The electrical cables, connections, terminals, are ok?
  - Anything is clogging the combustion air supply or exhaust system?

### Troubleshooting

If, after checking these items, the heater is still faulty or another malfunction occurs in your heater, please contact:

- If factory-installed, your contract workshop / garage.
- If subsequently installed, the workshop / garage which installed the heater.

#### **Please note!**

Please note that guarantee claims can expire if the heater is modified by a third party or if non-original parts are installed.

### Maintenance instructions

- Switch the heater on once a month for about 10 minutes, even outside the heating period.
- Before the heating period starts, the heater should undergo a trial run. If thick, persistent smoke develops, unusual burning noises or a clear fuel smell occurs or if electric / electronic parts overheat, the heater must be switched off and put out of service by removing the fuse. In this case, the heater should not be started up again until it has been checked by qualified staff who have been trained on Eberspächer heaters.
- Check the openings of the combustion air supply and exhaust system after longer standstill periods, clean if necessary!

### Service

#### Technical Support

If you have any technical questions or problems with the heater, the control unit or the operating software, please contact the following service address:  
support-UK@eberspaecher.com



## 7 Environment

### Certification

The high quality of Eberspächer's products is the key to our success.

To guarantee this quality, we have organised all work processes in the company along the lines of quality management (QM).

Even so, we still pursue a large number of activities for continuous improvement of product quality in order to keep pace with the similarly constantly growing requirements made by our customers.

All the steps necessary for quality assurance are stipulated in international standards.

This quality is to be considered in a total sense.

It affects products, procedures and customer / supplier relationships.

Officially approved public experts assess the system and the corresponding certification company awards a certificate.

Eberspächer Climate Control Systems GmbH & Co.KG has already qualified for the following standards:

**Quality management in accordance with  
DIN EN ISO 9001:2000 and ISO/TS 16949:1999**

**Environmental management system in accordance  
with DIN EN ISO 14001:1996**

### Disposal

#### Disposal of materials

Old devices, defect components and packaging material can all be separated and sorted into pure-grade factions so that all parts can be disposed of as required in an environment-friendly manner recycled where applicable.

Electric motors, control boxes and sensors (e. g. temperature sensors) are deemed to be "electronic scrap".

#### Dismantling the heater

The heater is dismantled according to the repair stages in the current troubleshooting / repair instructions.

#### Packaging

The packaging of the heater can be kept in case it has to be sent back.

### EU Declaration of Conformity

We herewith declare that the version of the heater placed on the market by us conforms to the applicable provisions of the following EU Directive.

EU Directive 2014/30/EU



The full Declaration of Conformity can be viewed and downloaded from the download centre under [www.eberspaecher.com](http://www.eberspaecher.com).

## 8 List

---

### List of abbreviations

**ADR**

European agreement about the international transport of dangerous goods on the road.

**EU type-approval**

Permit awarded by the Federal Vehicle Office for the production of a heater for installation in motorised vehicles.

**EMC directive**

Electromagnetic compatibility.

**JE-partner**

Eberspächer partner.

**FAME**

Biodiesel to DIN EN 14214.

**E85 ethanol fuel**

Petrol with 85 % ethanol to EN 15293 for adapted vehicle engines.

**ECE regulation**

Internationally agreed, uniform technical specifications for vehicles, parts and equipment of motor vehicles.









**[www.eberspaecher.com](http://www.eberspaecher.com)**

Eberspächer Climate Control Systems  
GmbH & Co. KG  
Eberspächerstraße 24  
D-73730 Esslingen  
[info@eberspaecher.com](mailto:info@eberspaecher.com)



**Eberspächer**