

ООО"ADVERS"

Russia, 443068, Samara,
Novo-Sadovaya Str., 106A

Factory

+7(846)263-07-97

Sales Department

+7(846)270-68-64; 270-65-09

E-mail: sales@autoterm.ru

Service Department

ООО"Сервисная Компания"

Russia, 443100, Samara, Lesnaya Str., 11A

+7(846)266-25-39; 266-25-41

+7(846)266-25-42; 266-25-43

E-mail: garant@autoterm.ru

E-mail: support@autoterm.ru

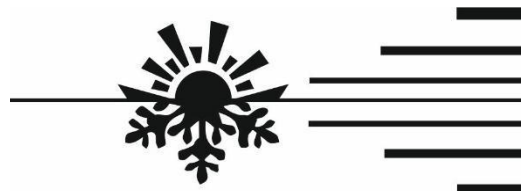

www.autoterm.ru

Air Heaters

PLANAR

Repair Manual

March 2016

Contents

1	Technical Specifications	4
2	Safety.....	5
3	Troubleshooting.	5
4	Heater Dismounting and Disassembly.....	11
5	Heater Components - Repair and Replacement.	14
5.1	<i>Functions, Removal and Replacement of Glow Plug.....</i>	14
5.2	<i>Functions, Removal and Replacement of Glow Plug Screen.....</i>	15
5.3	<i>Functions, Removal and Replacement of Overheat Sensor.</i>	16
5.4	<i>Functions, Removal and Replacement of Temperature Sensors (PLANAR-8DM).</i>	19
5.5.	<i>Functions, Removal and Replacement of Flame Indicator.....</i>	20
5.6	<i>Functions, Removal and Replacement of Air Blower.</i>	21
5.7	<i>Functions, Removal and Replacement of Control Unit.</i>	22
5.8	<i>Functions, Removal and Replacement of Combustion Chamber.</i>	23
5.9	<i>Functions, Removal and Replacement of Heat Exchanger.....</i>	25
5.10	<i>Functions, Removal and Replacement of Fuel Pump.</i>	25
5.11	<i>Functions, Removal and Replacement of Controller.</i>	26
5.12	<i>Functions, Troubleshooting and Replacement of Cabin Sensor.....</i>	27
6	Tools and Equipment for Maintenance and Repairs.....	28
7	Heater Check after Repair.....	29

This Repair Manual is intended for service personnel performing maintenance and repairs of PLANAR air heaters (hereinafter - "the heater") and their modifications. It describes methods of determining possible faults, how to determine the working condition of components and parts, and how to identify the need to replace them.

The Manual provides basic technical data, descriptions of components, their functions as parts of the heater, recommendations for their maintenance and repair, main distinctions of different models.

Principles of operation, main parts and components of the standard air heater are described in CPAU (the catalog of parts and assembly units).

Electrical diagram of the air heater is provided in the Operation Manual.

When repairing the heater, its Operation Manual and the catalog of parts and assembly units should be referred.

Repair Manual may not reflect minor design changes made by the manufacturer.

Abbreviations used in this Manual:

- CU –Control Unit;
- CC –Combustion Chamber;
- AB –Air Blower;
- CNTRL –Controller;
- FP–Fuel Pump;
- VEH –Vehicle.

1 Technical Specifications

Table 1 shows the Technical Specifications of the heater. The Specifications are given with the tolerance of $\pm 10\%$, obtained at 20°C and rated voltage.

Table 1

	PLANAR				
	2D	4DM2	44D	8DM	
Rated voltage, V:	12 / 24	12 / 24	12 / 24	12	24
Fuel	diesel fuel depending on ambient temperature				
Heating output, kW, at max/ min mode:	2 / 0,8	3 / 1	4 / 1	6 / 3,2	7,5 / 3,2
Hot air flow, $\text{m}^3/\text{hr.}$, at max/min mode:	75 / 34	120 / 70	120 / 70	175 / 70	235 / 70
Fuel consumption, l/hr., at max/min mode:	0,24 / 0,1	0,37 / 0,1	0,51 / 0,12	0,76 / 0,42	0,9 / 0,42
Power consumption, W, at max/min mode:	29 / 10	46 / 10	57 / 10	75 / 8	90 / 9

2 Safety

2.1. Repairs should be conducted in compliance with applicable occupational safety instructions.

2.2. Violation of the rules of operation of the air heater may cause a fire.

2.3. The workplace should be provided with fire-fighting implements.

2.4. Do not refuel when operating the heater.

2.5. Do not operate the heater in enclosed spaces and in areas with poor ventilation.

2.6. **Do NOT disconnect the heater from the power supply before the end of the purge cycle.**

2.7. In case of flame at the outlet of the exhaust pipe, the heater should be turned off and after it is stopped, troubleshooting can be started.

2.8. Do not connect or disconnect electrical connectors of the heater when the power is ON.

3 Troubleshooting.

During operation, the air heater may malfunction. A malfunction is identified by the code displayed on the controller panel, see Table 2 for code descriptions.

Other malfunctions are possible, which are not identified by the control unit. For instance, loss of tightness of the heat exchanger (burn-out), or burn-out gaskets, or a decrease in heat output as a result of carbon formation inside heat exchanger. These faults can be detected visually.

DO NOT USE THE HEAT EXCHANGER IF IT LOSES ITS TIGHTNESS.

During operation of the air heater, failures of individual elements of the heater may occur, which can be replaced without removing the heater from the vehicle (e.g.: replacement of the fuel pump; glow plug, controller).

Attention! In September 2015, a standardization of fault codes was carried out, as a result some codes were changed.

Table2

Fault Code	Description	Fault Cause	Recommended Solutions
01	Overheating of the heat exchanger	The sensor sends a signal to shut down the heater. Heat exchanger temperature in the sensor zone is over 250°C	<p>Check the intake and outlet of the heating unit for unobstructed entry and exit of heated air.</p> <p>Check the integrity of the fan and its performance.</p> <p>Check the temperature sensor and replace it if necessary. (see items5.3-5.4)</p> <p>Inspect the heat exchanger.</p> <p>Check and remove carbon deposits from the inside of the heat exchanger, if necessary (see items5.8-5.9)</p>
02	Possible overheating at the intake temperature sensor. Sensor temperature (control unit) is more than 55 degrees.	Control unit is insufficiently cooled down during 5 min. purging before startup; or overheating of the control unit during operation.	<p>Check the intake and outlet of the heating unit for unobstructed entry and exit of air and re-start the heater to cool it down.</p> <p>Replacethe control unit. (see item5.7)</p>
05	Faulty temperature sensor (PLANAR-2D) or flame indicator	Short circuit to the casing or open circuit in the wiring of the sensor.	Check sensor as in5.3 or5.5,replace if necessary
04 or 06	Faulty temperature sensorin the control unit	Temperature sensor out of order (located in the control unit, cannot be replaced)	Replace control unit (see item5.7)
07	Overheat sensor- open circuit	Faulty sensor. Oxidation of contacts in the terminal block.	Check overheat sensor circuit for an open. Remove oxidation from the connector contacts.
08			See Fault Code29.
09	Faulty glow plug	Short circuit, open circuit, faulty control unit.	<p>Checkglow plug, replace if necessary. (see item5.1)</p> <p>Check the control unit, replace if necessary. (see item5.7)</p>

Table2

Fault Code	Description	Fault Cause	Recommended Solutions
10	Electric motor of the air blower does not develop the necessary speed.	Increased friction in the bearings or contact between the impeller and fan shroud in the blower. Faulty electric motor.	Check electric motor, if possible correct the fault; replace air blower if necessary (see item5.6).
11	Faulty air temperature sensor (intake) only for PLANAR-8DM.	Mechanical fault. Oxidation of contacts in the block.	Check connecting wires. Check sensor (item5.4).
12	Shut down, overvoltage more than 30V (for 24V) or more than 16V (for 12V).	Faulty voltage regulator. Faulty battery.	Check battery terminals and wiring. Check the battery, charge it or replace if necessary.
15	Shut down, low voltage, less than 20V (for 24V) or less than 10V (for 12V)		
13	The heater does not start - two automatic start attempts failed.	No fuel in the tank	Fill the fuel tank.
		Fuel grade does not match the operating conditions at low temperatures.	Replace fuel, see Operation Manual.
		Insufficient supply of fuel.	Eliminate fuel line leakage or blockage. Check the performance of the fuel pump, replace if necessary (see item5.10).
		Clogged exhaust duct or combustion air intake.	Clean air intake or exhaust duct of possible clogging.

Table2

Fault Code	Description	Fault Cause	Recommended Solutions
13	The heater does not start - two automatic start attempts failed.	Insufficient pre-heating of the glow plug, faulty control unit.	Check the plug, replace if necessary (see item5.1). Check voltage supplied by control unit, replace if necessary.
		The impeller touches the fan shroud in the blower, and, as a result, flow of air into the combustion chamber is reduced.	Replace blower after determining its malfunction. (see item5.6).
		The glow plug housing in CC is clogged. Clogged glow plug screen or it is not installed all the way into housing.	Clean the glow plug hole. Replace the glow plug screen, if needed, and install it in accordance with item5.2.
16	During the purge time, temperature sensor was not cooled down. Time for ventilation was exceeded.	During5 min purge before start-up, temperature sensor was not sufficiently cooled.	Check the intake and output of the heater for unobstructed entry and exit of air. Check the integrity of the fan and its operation. Checkthe sensor, replace if necessary.
17	Faulty fuel pump	Short circuit or open circuit in the wiring of the fuel pump.	Check the wiring of the fuel pump for short circuit and open circuit. Check the wires to overheat sensor, insulation integrity.
20	Heater does not start	Burnt out fuses on the power harness.	Check the fuses andreplace if necessary.
		No communication between the controller and the control unit. Controller receives no data from the control unit.	Check the connectors and the green wire in the connecting harness. Remove oxidation from connectors. Check the controller and the connecting harness, replace if necessary. If the controller is operational, replace the control unit.

Table2

Fault Code	Description	Fault Cause	Recommended Solutions
27	Motor does not rotate	Damaged bearing or rotor, foreign objects, etc.	Check connectors and wiring leading to the electric motor board and the control unit. Eliminate the fault, if possible. (see item 5.6)
28	Motor rotates. Speed is not regulated.	Faulty electric motor control board or heater CU.	Replace air blower.
08 or 29	Flame failure during operation of the heater.	Insufficient fuel supply. Faulty fuel pump. Faulty flame indicator.	Check for leaks or clogging of fuel lines, tighten the clamps on the fuel lines. Check combustion air intake and exhaust pipe. Check the amount of fuel supplied by the fuel pump, and replace it if necessary. (see item 5.10) If the heater starts, check flame indicator and replace it if needed. (see items 5.3 or 5.5)
30	Heater does not start	No communication between the controller and the control unit. Control unit receives no data from the controller.	Check connectors and white wire in the connecting harness. Remove oxidation of connectors. Check controller and connecting harness, replace if necessary. If controller is operational, replace control unit.
31	Overheating of hot air outlet temperature sensor. Planar 8DM	Hot air temperature sensor gives a signal to turn off the heater.	Check the temperature sensor (item 5.4) only PLANAR-8DM

Table2

Fault Code	Description	Fault Cause	Recommended Solutions
32	Faulty temperature sensor at air intake.	Faulty temperature sensor at air intake.	Check connecting wires. Check sensor (item 5.4). only PLANAR-8DM
33	Heater control is blocked	Error "Overheating" repeated three times.	See instructions for unblocking the heater. only for PLANAR-8DM
34	Wrong component assembly	One of the temperature sensors (intake, output or overheating) is installed in wrong location and gives wrong signal.	Check location of temperature sensors. Check sensors (item 5.4) only PLANAR-8DM
35	Flame failure	Supply voltage drop.	Check the battery, wiring. (Voltage drop may occur due to prolonged use of electric starter) only PLANAR-8DM
36	Flame indicator temperature above normal	Faulty flame indicator. Malfunction of the stabilizer in combustion chamber.	Check flame indicator (item 5.5). Inspect combustion chamber. (item 5.8) only for PLANAR-8DM
78	Flame failure during operation.	Air bubble in fuel system. Faulty fuel pump. Faulty flame indicator.	Check fuel lines for leaks or clogging. Tighten fuel line hose clamps. Check combustion air intake and exhaust duct.

4 Heater Dismounting and Disassembly.

Replacement or checking of the heater components requires its partial disassembly. **Partial disassembly of the mounted heater is allowed, if there is an access to the dismantled components.**

4.1. –Dismounting and Disassembly of PLANAR-2D

- remove the heater from VEH;
- remove the upper and lower casings;

Casing should be removed as follows:

- a) Remove clips. To remove clip, use screwdriver (with a thin tip) to pry the clip out and slide it left or right for full release (Fig. 1);
- b) Remove grids rotating them in either direction;
- c) Remove upper and lower casing shells.

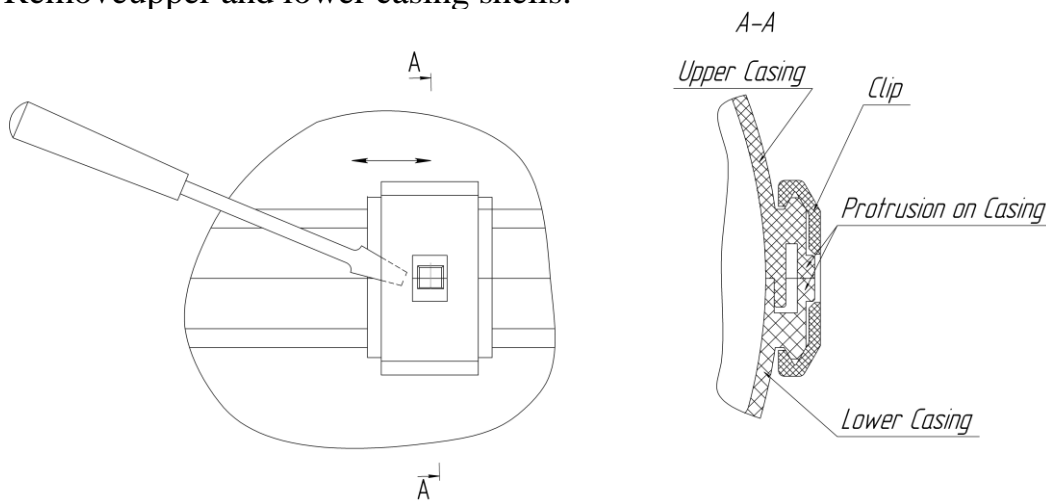

Fig.1- Removal of clips from casing.

- disconnect the contacts from the control unit (1 – glow plug contacts, 2 – sensor contacts, 3 – AB contacts);

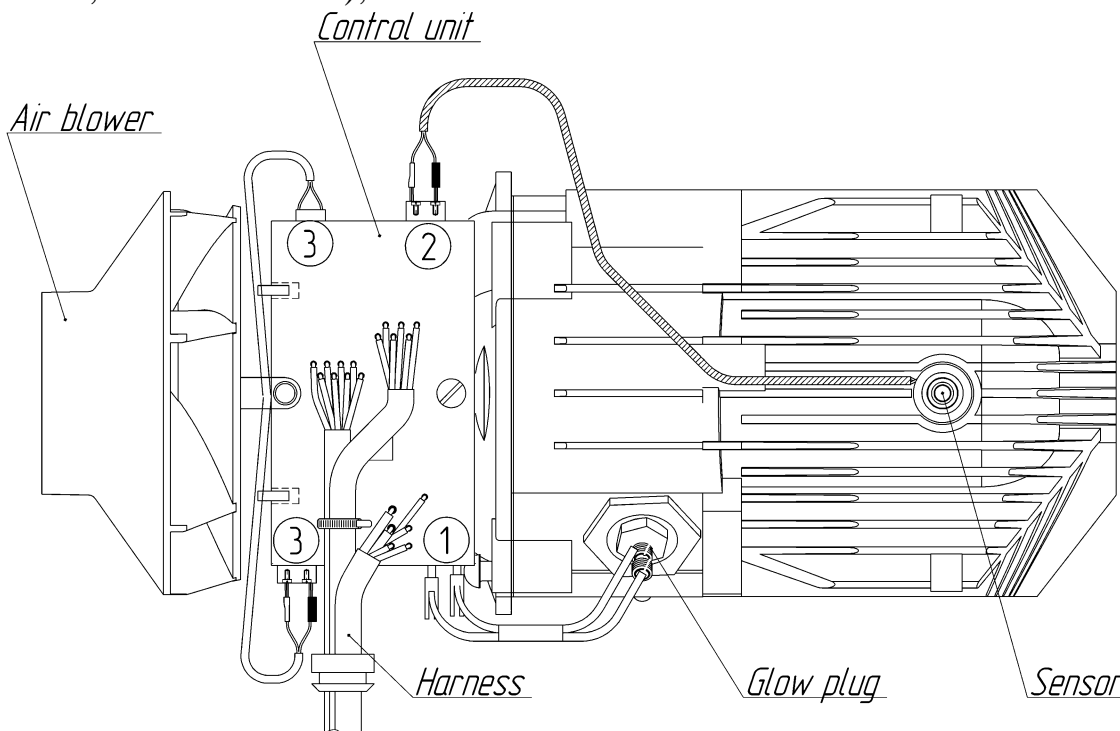

Fig.2–Heater.

- remove glow plug and bushing (use S=27 to hold bushing, and S=12 to turn glow plug out);

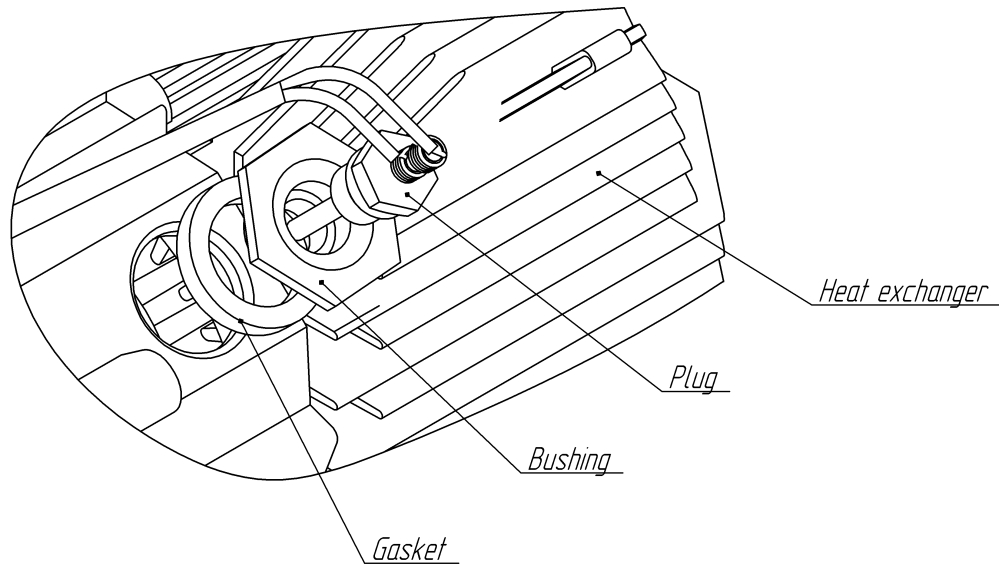

Fig. 3 – Plug with Installation Kit.

- remove secure screw of CU and dismount it;
- remove screws fastening AB to heat exchanger and disconnect AB;
- remove screws fastening screen to CC, remove screws fastening CC to heat exchanger, remove CC;

4.2. – Dismounting and Disassembly of PLANAR-4DM2

- remove heater from VEH;
- remove fastening screws of the plug cover, remove fastening screws of casing, remove casing halves;
- disconnect glow plug connector and other connectors from control unit;
- remove fastening screw of the control unit and dismount it;
- remove glow plug from bushing and turn bushing out;
- remove screws fastening AB to the intermediate unit and disconnect AB;
- remove screws fastening the intermediate unit to the heat exchanger (inside housing of the intermediate unit) and remove intermediate unit
- remove screws fastening CC to heat exchanger

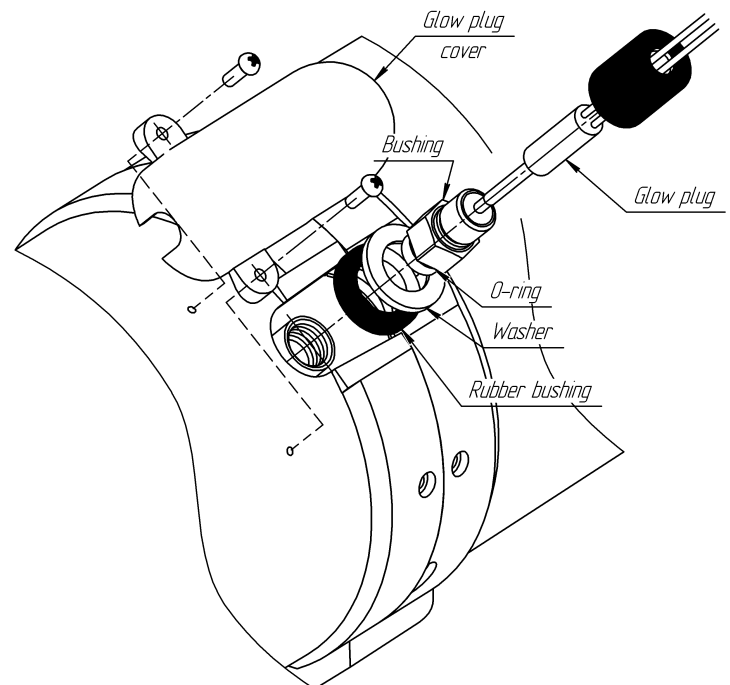

Fig.4–Glow plug with Installation Kit.

4.3. – Dismounting and Disassembly of PLANAR-44D

- remove heater from VEH;
- remove upper and lower casing shells (Fig.1);
- disconnect contacts from CU, remove fastening screw of CU, dismount it;
- turn out glow plug;
- remove screws fastening AB to intermediate unit and dismount AB;
- remove screws fastening intermediate unit to heat exchanger and dismount intermediate unit together with CC;
- remove screws fastening CC to intermediate unit.

4.4. – Dismounting and Disassembly of PLANAR-8DM

- remove heater from VEH;
- remove fastening screws of glow plug cover and control unit;
- disconnect all contacts from CU, dismount CU;
- remove fastening screws of casing halves, dismount them;
- remove glow plug cap, unscrew glow plug;
- remove fastening screw of AB from intermediate unit, dismount AB;
- disconnect CC with intermediate unit from heat exchanger (unscrew nuts on the perimeter of intermediate unit);
- remove screws fastening CC to intermediate unit.

5 Heater Components - Repair and Replacement.

5.1 Functions, Removal and Replacement of Glow Plug.

The glow plug provides ignition of fuel mixture during start-up of the heater. Removal and replacement of glow plug is described in Section 5.

Model	Glow Plug Operating Voltage	Heater Operating Voltage
PLANAR-2D	9V	12V
PLANAR-4DM2	18V	24V
PLANAR-44D		24V
PLANAR-8DM	12V	12V
		24V

Performance check instruction:

Remove glow plug from the bushing, connect it to CU and start the heater. Note how glow plug heats up, it should start heating up from the tip to the middle of the heating element. If the heating element heats up from the middle or from the tip and to the base, then the glow plug is faulty.

If the glow plug heats up insufficiently, check the voltage outputted by CU to the glow plug connector. The supply voltage should be $\approx 9, 12, 18V$ (depending on the model). If the voltage readings do not match, replace the CU. If after the replacement of the CU the heater is operational, the replaced CU is considered failed.

If glow plug is not heating up, check its operation. To do this, disconnect glow plug connector, connect glow plug to DC power supply with voltage of 9, 12, or 18V (depending on glow plug model), and after 30 seconds, measure the current.

Current should be between 5.2 to 6.78A (for 9V), from 3 to 5.2A (for 12V) and 2.5 to 3.4 (for 18V). Test time - no more than 90 seconds. Time between tests no less than 180 seconds.

If glow plug does not meet any of the above requirements, it should be replaced. Glow plug replacement is performed in reverse order. Before installation, check O-rings for weariness.

If glow plug is OK, check the wires and wire contacts on the control unit. If the contacts are clean, replace CU and repeat the start. If after replacing CU heater is operational, then replaced CU is considered failed and must be replaced.

5.2 Functions, Removal and Replacement of Glow Plug Screen

The screen is designed for uniform fuel supply to the CC. When replacing or checking glow plug, it is necessary to check the screen for carbon deposits or clogging. If there are carbon deposits, the screen should be replaced. In most cases removed screens get damaged and are not re-usable. Install the screen using mandrel (Fig. 6) according to Fig.5, all the way in (until the screen touches the evaporator in the combustion chamber). Before installing replacement screen into the housing (bushing) clean the hole "A" located on the cylindrical surface of the glow plug housing (bushing). The hole in the screen should be positioned at $\approx 45^\circ$ away from the fuel tube.

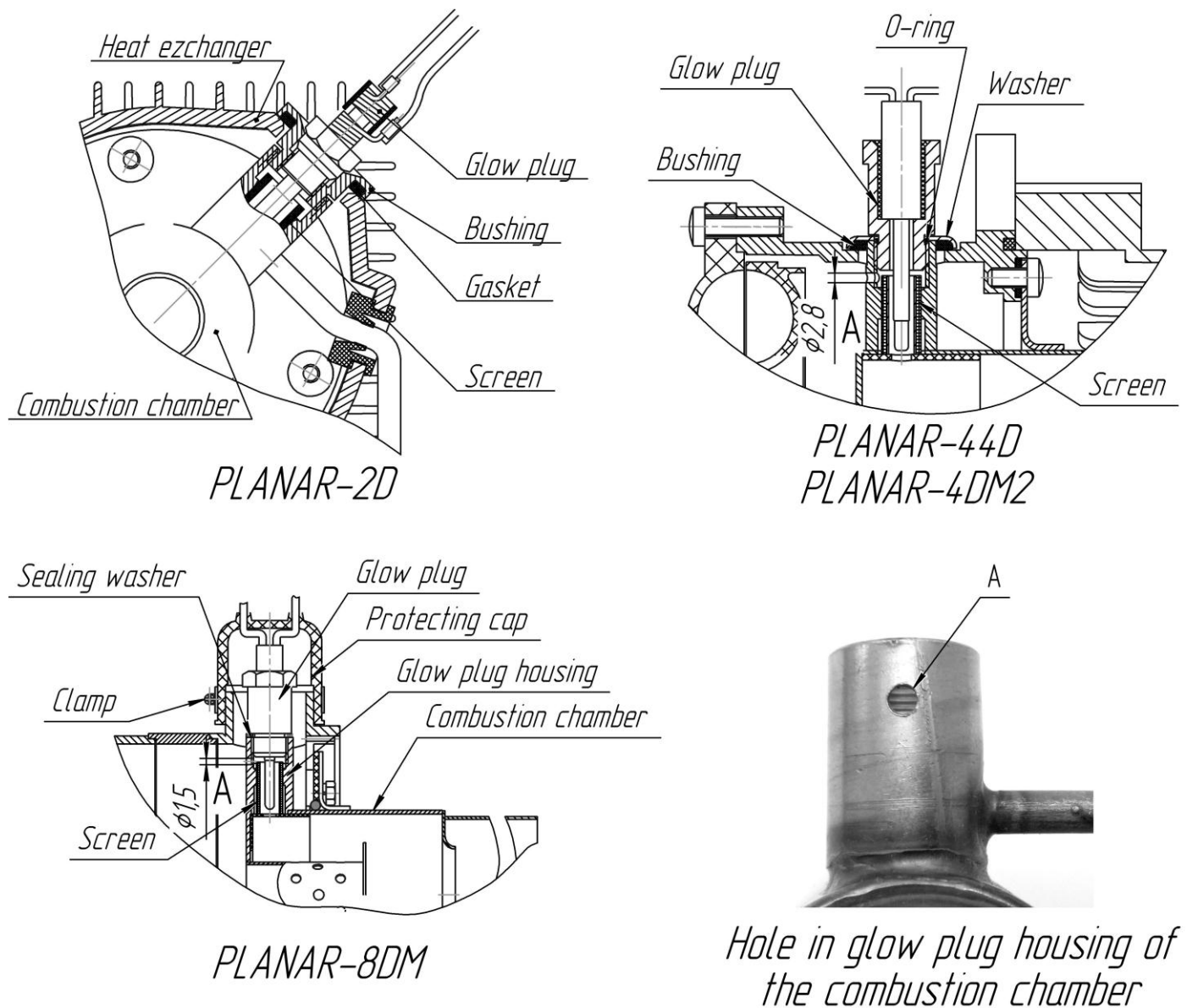
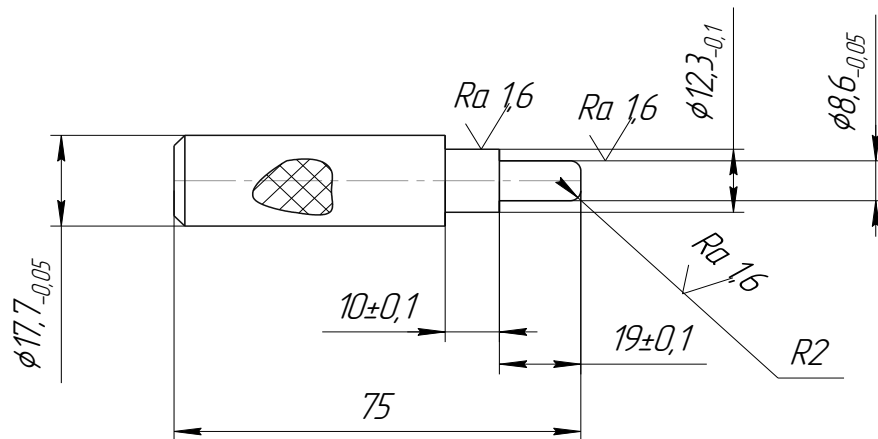

Fig.5. Installation of Plug and Screen in the Fitting of the Combustion Chamber.



1. MATERIAL STEEL 40XH GOST 4543-71 or similar
2. HRC 45-50

Fig. 6- Mandrel Dimensions.

**Attention! The screen should be installed with interference fit until it stops.
If the screen is not properly installed, the heater may malfunction during start-ups.**

DO NOT DRIVE SCREEN INTO HOUSING USING BUSHING OR GLOW PLUG.

5.3 Functions, Removal and Replacement of Overheat Sensor.

5.3.1–Bimetal overheat sensor.

Overheat sensor (Figure 7) is used to control the heating temperature of the heat exchanger. If heat exchanger temperature exceeds 250°C the heater shuts down. The overheat sensor requires replacement if the heater shuts down at heat exchanger's temperature below 250°C , or for the reasons set out in Table 2.

If you receive the error "Overheating" at starting or during operation, then:

- 1) Check the integrity of sensor wire insulation.
- 2) Check overheat sensor electrical contacts.
- 3) Check the temperature sensor for short circuit. In a cool state ($<250^{\circ}\text{C}$) the sensor is closed and reads "short-circuit". If this does not happen, replace the sensor.
- 4) Replace the overheat sensor and test the heater. If the heater is operational with new sensor, the replaced sensor should be considered faulty and disposed.
- 5) Check the CU. Connect overheat sensor wires (Figure 7a), start the heater.
 - If there is an error "Overheating" – the CU is faulty. Replace the CU.
 - If the heater is working properly - disconnect the closed wires. The control panel should display the error "Overheating". If the error does not appear - the CU is defective. Replace the CU.

Disassembly in accordance with section 4.

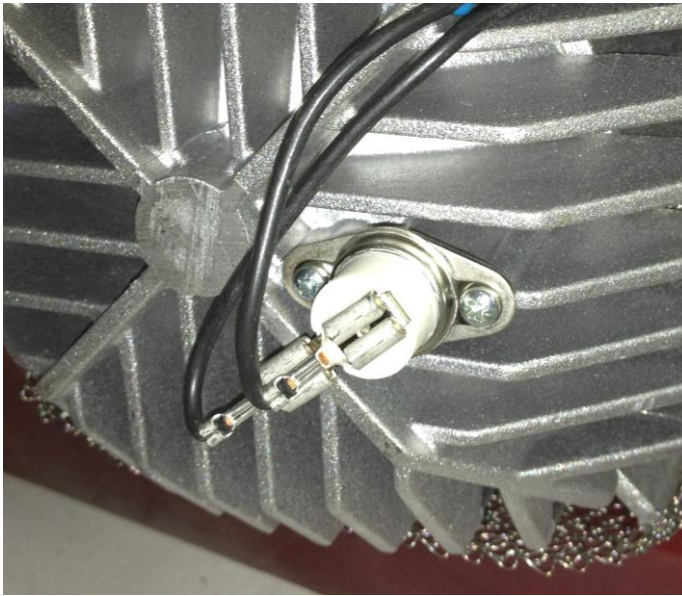

Fig.7 – Overheat sensor



Fig.7a – Closed Wires

Install replacement heat sensor in reverse order.

Remove dirt or oil from contacts with a clean cloth soaked with degreaser. Upon detection oxidation on contacts, clean them with fine sandpaper, wash with degreaser, and tighten for proper connection.

5.3.2 Thermocouple overheat sensor.

Since November 2015, heaters PLANAR-44D and PLANAR-8DM are equipped with a thermocouple overheat sensor. PLANAR-2D has always been equipped with this sensor.

The sensor is mounted on the heat exchanger and made in a form of ring with an inbuilt thermocouple with two conductors. For heaters PLANAR-2D it performs the functions of overheat sensor and flame indicator (Fig.8). During operation, the sensor monitors the temperature of the heat exchanger. When heat exchanger temperature goes exceeds 250°C, the heater shuts down automatically. The sensor has to be replaced if the heater shuts down as described in Table 2.

Disassembly is performed according to Section 4. To dismount the sensor from the heater, remove the lock washer and the sensor (Fig.8).

Installation replacement overheat sensor in reverse order. The lock washer should be replaced with a new one.



Рис.8 – Overheat Sensor
(thermocouple)

Check the sensor for open circuit with a tester. If there is an open circuit fault, the sensor is defective.

Check insulation resistance between the terminals and the housing. The resistance should be not less than 100 MOhm at 100V. Ambient temperature during resistance measurements must be between 15 and 35°C, relative humidity less than 80%. If insulation resistance does not meet this requirement sensor should be replaced.

Check the sensor terminal on the control unit. Install a jumper instead of the sensor (Figure 9). If the heater starts with no fault code, the CU is OK. Turn off the heater and remove the jumper.

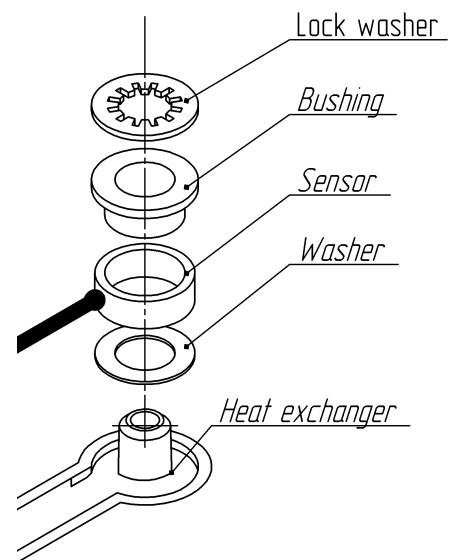
If an error occurs during operation of the heater, it is possible that there is a crack (open circuit fault) in the junction of the thermocouple sensor. There are two methods to identify the problem:

1. Disconnect sensor from control unit, connect sensor wires to the multimeter (to terminals of temperature measurement) and heat the sensor with heat gun or lighter. The temperature rise should be smooth. If the temperature changes suddenly, or it shows the initial value, the sensor is damaged. In this case, after cooling, the open circuit fault may disappear.

2. Disconnect the sensor from the heater, and measure the voltage generated by the sensor when heated. When the sensor is heated to +100°C (temperature of boiling water), the voltage should be approximately 3 millivolts. The voltage on the terminal marked with red, should be of positive polarity relative to the terminal marked with black.

Check the polarity of the sensor connection to the CU (wire with black marking is connected to the connector terminal of the CU with a black dot). A magnet can be used to check the correctness of marking. Contact of the wire with the black mark is magnetic. If necessary, swap the terminals in the sensor connector of the control unit.

In the case of an open circuit fault, sensor is defective and should be replaced.

To check the sensor terminal in the CU, install a jumper instead of the sensor (Fig.9).

- If the heater is started and there is no sensor fault, the CU is OK. Remove the jumper and connect a working sensor.
- If the problem persists, replace the CU.

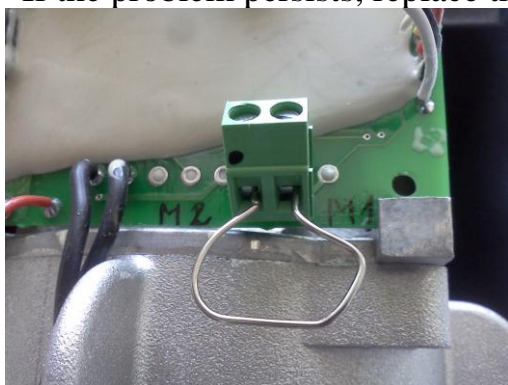

Fig. 9 – Jumper

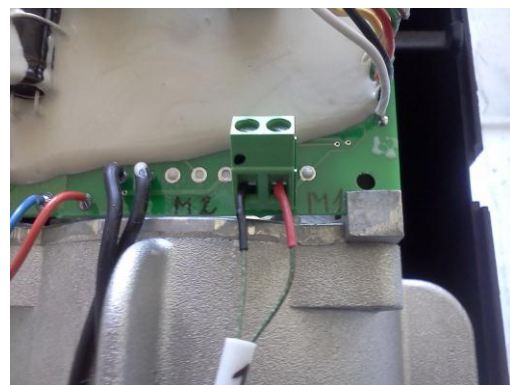

Fig. 9a – Connection

Remove dirt and oil from the contacts with a clean cloth soaked in degreaser.

5.4 Functions, Removal and Replacement of Temperature Sensors (PLANAR-8DM).

5.4.1 Since January 2015, PLANAR-8DM heaters are equipped with a temperature sensor for heated air.

The sensor is installed at the heated air outlet and is connected to the CU. Disassembly is performed in accordance with Section 5.

Sensor performance (with power applied to the heater) can be determined by the output voltage.

The output voltage at 0°C is -2,73V. Voltage increases with temperature. As the temperature increases by 1°C, the output voltage will increase by 10mV. Compare the room temperature and the corresponding voltage outputted by the sensor.

If the sensor gives incorrect voltage, it is necessary to replace the sensor.

To avoid mistakes when evaluating performance of the sensor, it is necessary to substitute it with a known-good. If the cause of heater failure is eliminated with the installation of the new sensor, then the old sensor is considered to be inoperable and has to be replaced.

When replacing the temperature sensor, installation is in the reverse sequence. If the problem persists, replace the control unit to a known-good.

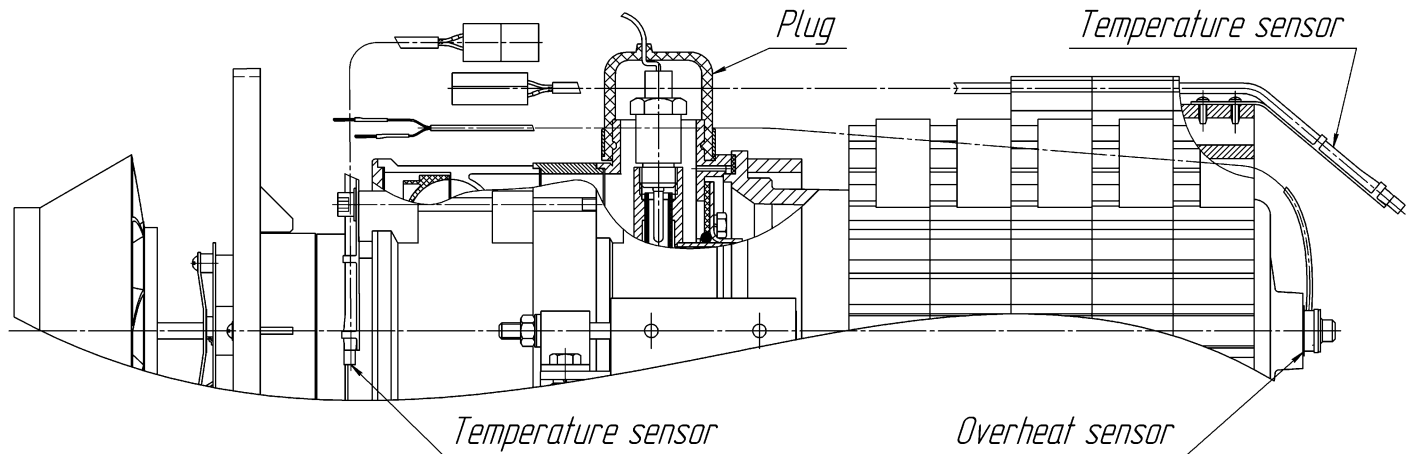

Fig.10–Sensors.

5.4.2 From October 2015, heaters are equipped with an additional heated air temperature sensor.

The sensor is checked as described in 5.4.1.

5.5. Functions, Removal and Replacement of Flame Indicator.

Flame indicator is used to monitor presence of flame in the combustion chamber. It is a metal tube with a built-in thermocouple.

If an error is displayed when the heater is turned on, check the flame indicator for continuity with a tester. If there is a break, the indicator is defective and should be replaced;

Check the flame indicator channel of the control unit. For that, set a jumper instead of the flame indicator (Figure 9). If the flame indicator fault code is not displayed at the start of the heater, the CU is OK. Turn off the heater and remove the jumper.

Check insulation resistance between the terminals and the indicator casing. The resistance should be not less than 100 MOhm at a voltage of 100V. Ambient temperature during resistance measurements should be between 15 and 35°C, relative humidity less than 80%. If insulation resistance does not corresponds to this requirement, it is necessary to replace the flame indicator.

If an error occurs during operation of the heater, it is possible that there is a crack (open circuit fault) in the junction of the thermocouple of the flame indicator. There are two methods to identify the problem:

1. Turn out the flame indicator, connect its contacts to the multimeter (to the terminals of temperature measurement) and heat the sensor, for instance with a cigarette lighter. The observed temperature rise should be smooth. If the temperature changes suddenly, or assumes its initial value, the indicator is damaged. In such a case, the open circuit fault may disappear after cooling off of the indicator.

2. Turn out the flame indicator from the housing, and measure the voltage generated by the indicator when heated. When the indicator casing is at +100°C (temperature of boiling water), the voltage should be approximately 3 millivolts. The voltage on the terminal marked with a red tubing, should be of positive polarity with respect to the terminal marked with a black tubing.

In the case of an open circuit fault, the flame indicator is defective and should be replaced.

To avoid mistakes when evaluating performance of the flame indicator, it is necessary to substitute it with a known-good. If the cause of the heater failure is eliminated with the installation of a new flame indicator, then the old flame indicator is considered to be inoperable and has to be replaced.

If the problem persists, check the polarity of the connection of the flame indicator to the CU (wire with black marking is connected to the connector terminal of the CU with a black dot, Fig. 7b). A magnet can be used to check the correctness of wire marking. Contact of the wire with the black mark is magnetic.

5.6 Functions, Removal and Replacement of Air Blower.

The blower (Fig.11) consists of an electric motor with a volute. The motor shaft carries an impeller on the volute side (for air supply into the combustion chamber), and a fan on the other side (for heated air supply).

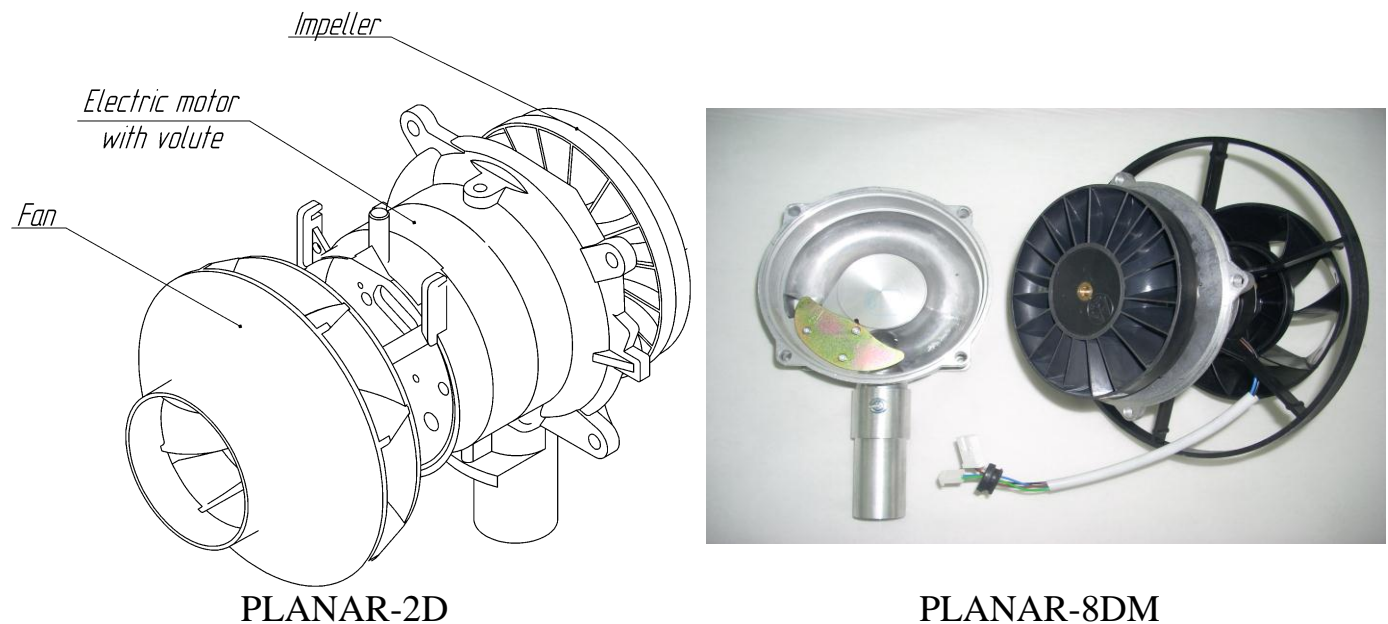

Fig.11–Air Blower.

Rotating impeller generates air flow in the annular channel of the volute, which enters the combustion chamber to ensure combustion, and also purges the combustion chamber while cooling it and removing remaining fuel and moisture before and after the combustion process.

The fan creates a flow of air that passes through the radiators of the heat exchanger, when the heater is in operation, is heated, and the heated air enters the vehicle cabin or other interior spaces of the vehicle.

Troubleshooting the air blower:

- 1) Check cleanliness of the contacts connecting AB to CU;
- 2) Check the performance of the AB. To accomplish this, briefly connect the terminal of the blue wire (white block, PWM) to the terminal of the black wire (Figure 12) with a jumper, a thin wire. The heater should be connected to the power supply, but turned off. If the fan starts to spin - the AB is OK.
- 3) Check the AB for the absence of "blind spots". For this purpose, connect the terminal of the blue wire to the terminal of the black wire (Figure 12) multiple times, while changing the position of the fan, to verify if the AB starts in every position possible. If there are any "blind spots" - the AB is defective.

4) Check the performance of the speed measurement channel. To do this, connect the contacts of blue and black wires (Figure 12), and measure the pulse frequency on the green wire with a digital tester. When the AB is gaining speed, the pulse frequency should increase. Open the contact. The AB will start to slow down, and the pulse rate will begin to decline. If any of these conditions is not met, the AB is faulty.

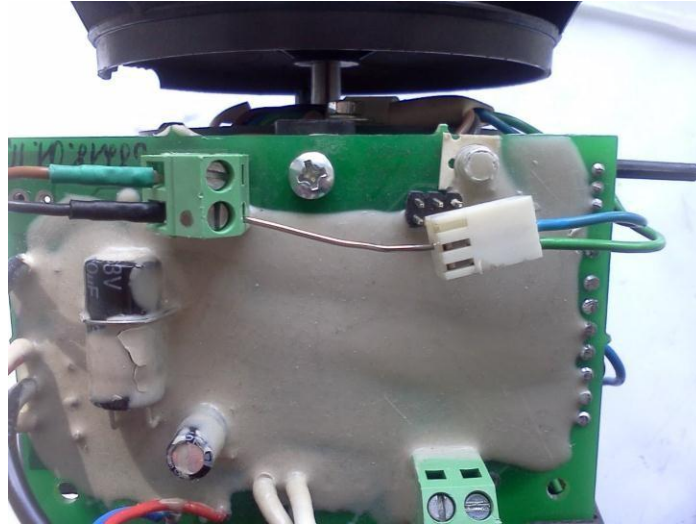

Fig.12–Control signal (PWM) connections in motor testing.

In case of failure of the electric motor or the impeller (the impeller touches the volute), it is necessary **to replace the whole air blower with a new one.**

If the fault persists with the new AB, check the CU.

5.7 Functions, Removal and Replacement of Control Unit.

CU provides control of the heater, together with the controller.

CU performs the following functions:

- a) initial assessment (check of readiness for work) of the heater components at startup;
- b) assessment of how the heater components function during operation;
- c) heater startup;
- d) heater shutdown:
 - on command from the controller;
 - in case of failure of one of the controlled components;
 - when the controlled parameters go beyond the permissible limits (temperature, voltage);
 - in case of flameout in the combustion chamber.

When a malfunction of the CU is detected, make sure that connecting cables, wires and connectors of the heater have no faults. Check the controller. Replace the CU with a known-good CU. If after replacing the CU the heater becomes operational, the old CU is considered inoperative and should be replaced.

5.8 Functions, Removal and Replacement of Combustion Chamber.

The combustion chamber of evaporative type is designed for air-fuel mixture combustion.

Signs of CC malfunction are: failure of the heater to start (if all other heater elements are in good condition), reduced heat output, burnout of the housing or internal parts of the camera, flameout.

Inoperable CC needs to be replaced. Partially dismantle the heater and evaluate the state of the CC for deformations, soot, burning, damage of structural elements.

When CC is replaced, is necessary to assess the condition of the heat exchanger. If, during the assembly/disassembly any gaskets were damaged, they should be replaced.

Components in different models:

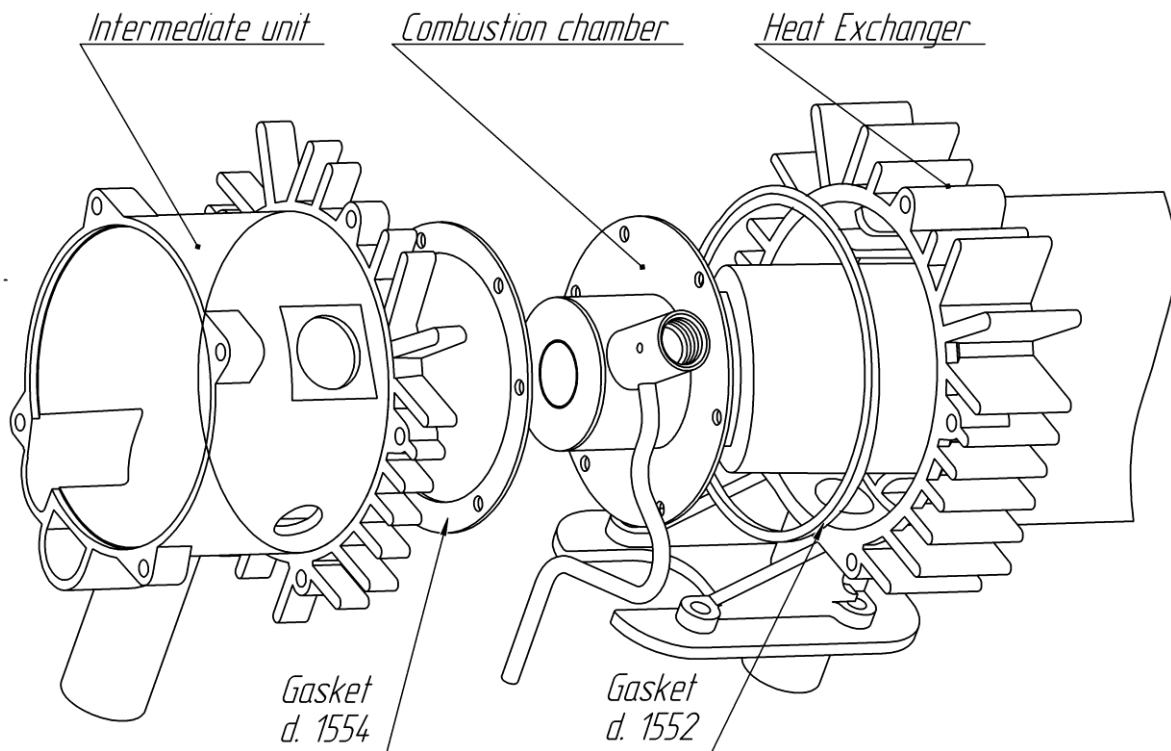

Fig.13–Combustion Camera in PLANAR-44D.

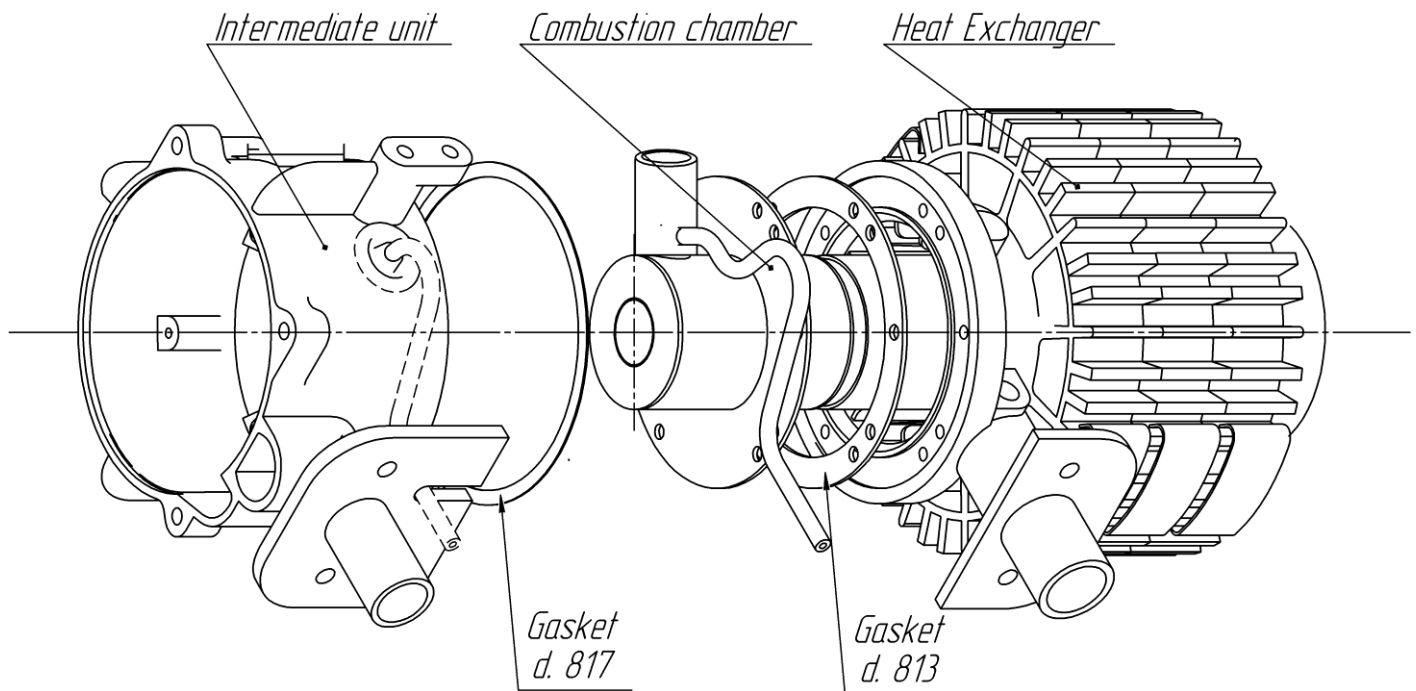

Fig.14–Combustion Camera in PLANAR-4DM2.

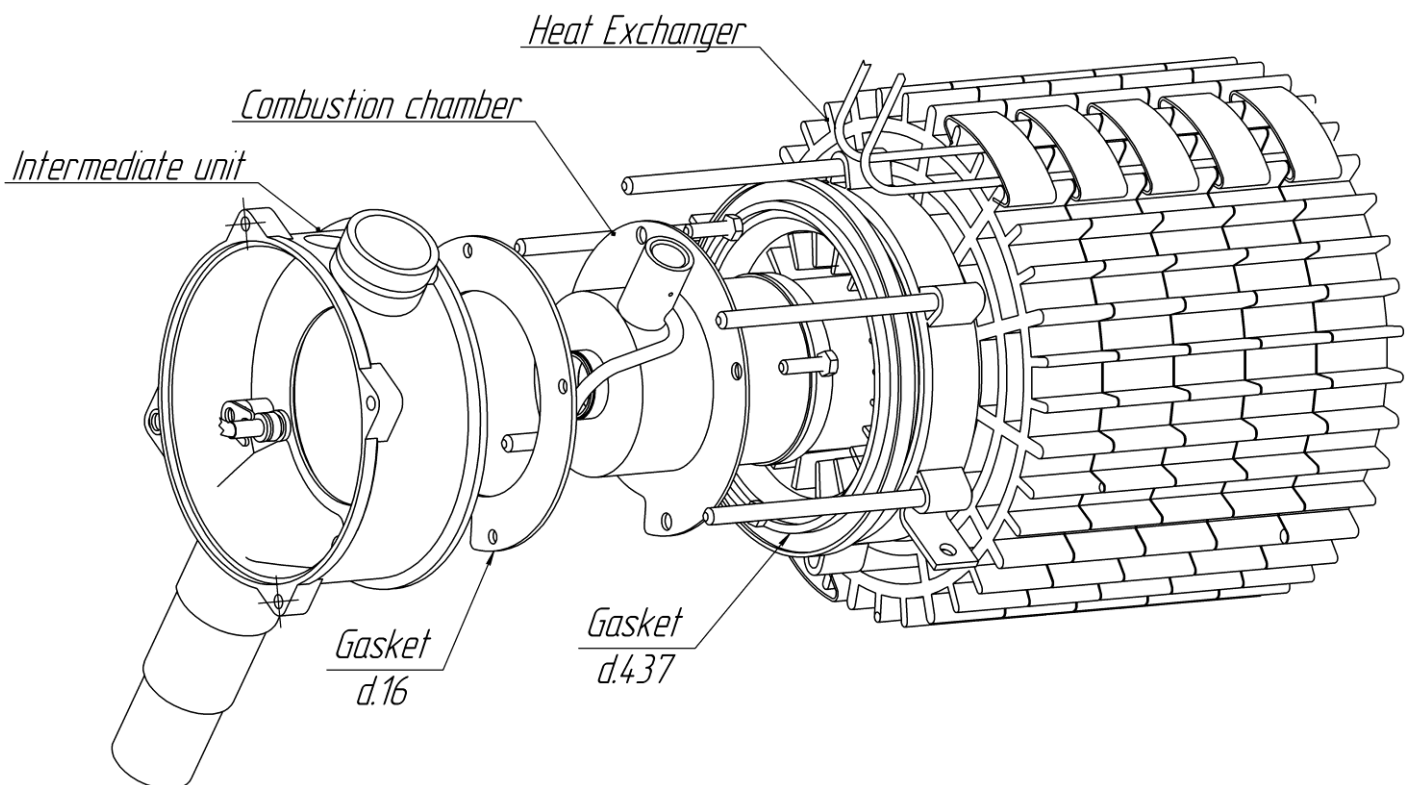

Fig.15–Combustion Camera in PLANAR-8DM.

Heaters PLANAR-2D had combustion cameras of two types.
 1 type (till January 2015) – screen is attached directly to the CC;
 2 type (after January 2015) – screen is attached through a bushing.



Fig.16 - Bushing



Before January 2015.



After January 2015.

Fig.15–Combustion Chamber of PLANAR-2D heaters.

5.9 Functions, Removal and Replacement of Heat Exchanger.

The heat exchanger is designed to transfer heat from hot gases generated by the combustion of air-fuel mixture in the CC to radiators, which in their turn, heat up the air stream passing along the edges of radiators.

During operation of the heat exchanger such faults may occur as: loss of heat conduction, increase in temperature of exhaust gas (more than 500°C), burn-out of the heat exchanger walls. Failures occur due to deposits of combustion products on the inner walls and fins of the heat exchanger and also due to the use of a poor fuel.

Inspect the inside of the heat exchanger, clean it from soot and carbon black, if necessary. When replacing the heat exchanger, assembly is performed in reverse order. If, during the assembly/disassembly any gasket is damaged, it should be replaced.

5.10 Functions, Removal and Replacement of Fuel Pump.

The fuel pump is used for metering fuel into the combustion chamber. Heaters are equipped with fuel pumps Thomas Magnete. This pump can not be repaired, it should be replaced with a new one.

Possible problems of the heater's fuel pump:

- a) during startup, fuel is not supplied to the fuel tube of the heater, and the characteristic knocking sound is not heard in the fuel pump;
- b) the fuel pump operates, but fuel is not supplied to the fuel tube of the heater;
- c) interruption of combustion when the heater reaches its "max" mode, i.e. the fuel pump does not provide the required amount of fuel.

Troubleshooting and determination of productivity of the FP are performed as follows:

- before starting troubleshooting, check availability and quality of fuel in the tank;
- make sure that the wiring and connectors are in good condition;
- make sure that the FP works when the heater is turned on, and the characteristic knocking sound of piston movement inside the pump can be heard;

It is allowed to remove the FP and shake it to eliminate potential sticking of the piston within the pump due to prolonged storage or failure to perform required maintenance;

To check the working condition of the FP, you can directly connect a power supply, corresponding to the operating voltage of the pump, to the FP terminals for a short period (imitating pulses). If you hear the knocking sound, the fuel pump is working;

- check the tightness of the fuel line all the way from the tank to the FP and from the FP on to the heater.

If all of the above-mentioned problems are resolved, it is necessary to check the fuel pump performance. The fuel pump output should be $6.5 \div 7.3$ ml per 100 strokes. If its performance is less or more, then the fuel pump should be replaced.

FP performance check is carried out by means of the fuel-priming device UPT-4.

5.11 Functions, Removal and Replacement of Controller.

The controller (Fig.17) has the following functions:

- start and stop of the heater in manual mode;
- choice of operation modes, by power or by temperature;
- display of the set temperature or power;
- display of temperature (from the sensor integrated in the heater, the controller, or remote when connected);
- display of a fault code in case of heater malfunction.

To determine the performance of the controller, press any button on the controller. It causes a light indicator on the controller to illuminate.



Fig. 17–Controller

If when you press a button, the indicator on the controller does not light up, check the wiring, the power supply voltage of the controller, and electrical contacts of the terminals.

Any dirt or oil should be wiped off the contacts with a clean cloth soaked in gasoline.

If after the removal of defects the controller still does not work, it is necessary to replace the controller. If after the replacement the cause of the fault is corrected, the old controller is considered to be inoperable and it should be replaced. The controller can not be repaired, it should be replaced by a new one.

If after the replacement of the controller the heater malfunction persists, check the wiring and the CU.

5.12 Functions, Troubleshooting and Replacement of Cabin Sensor (it is available as an option)

The cabin sensor (Figure 18) is used to measure air temperature in the area of its installation, and it allows to maintain desired temperatures within $1 \div 30^{\circ}\text{C}$.

The performance of installed sensor can be determined by the operation of the heater.

If the heater does not maintain the desired temperature:

- measure the temperature in the sensor area and compare its value with the value displayed on the CNTRL;
- replace the sensor with a known good and retest.

If the heater with a new sensor is working properly, the old sensor is defective and should be replaced. If the heater with a new sensor still does not maintain the set temperature - check the CU.

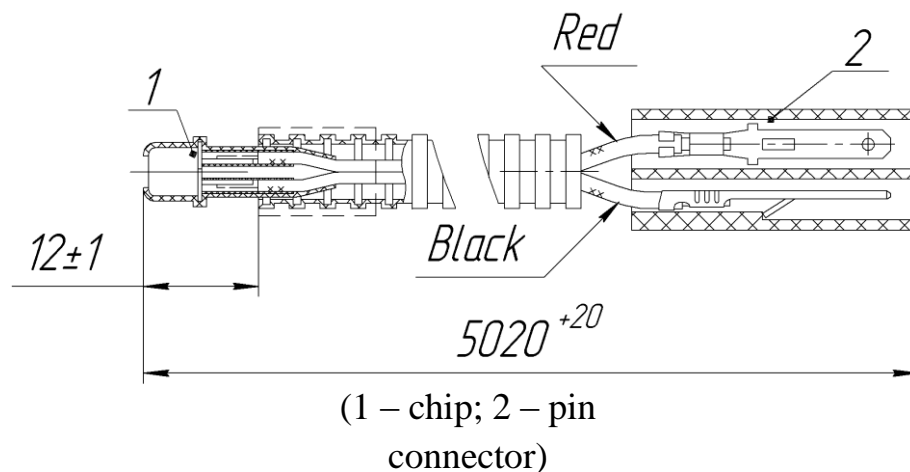

Fig. 18–Cabin Sensor

Sensor performance (during heater operation) can be determined by the output voltage.

The output voltage at 0°C - 2.73V. The voltage increases with increasing temperature. As the temperature increases by 1°C , the output voltage will increase by 10 mV.

Attention! The cabin sensor, if installed, should be disabled, if you have to run the heater when the air temperature is more than 30°C .

6 Tools and Equipment for Maintenance and Repairs.

6.1 Test Stand.

Maintenance and repair of liquid and air heaters is carried out on the stationary test stand DV 1105.000 (Figure 19) manufactured by OOO ADVERS.

The stand is designed for the following operations:

- a) testing liquid and air heaters using a diagnostic device and determination of their faults;
- b) checking the performance of a fuel pump, air blower, temperature and overheat sensors, flame indicator, glow plug;
- c) checking the performance of liquid and air heaters after repairs.

Key features and work procedures on the stand are described in the operation manual for DV1105.000.

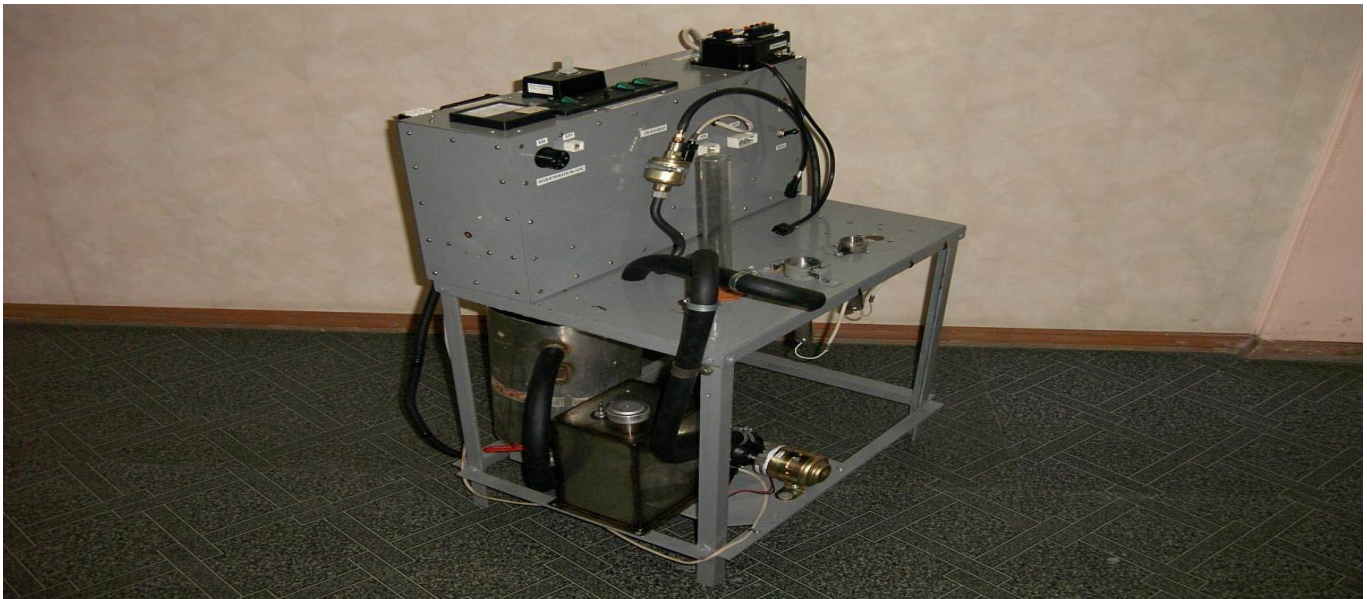

Fig19- Test Stand.

Note. This stand allows you to perform quick and high quality repairs of liquid and air heaters.

6.2 USB adapter.

The USB adapter is designed for connecting liquid and air heaters to a personal computer (PC). It is used to obtain data on the status of the liquid or air heater.

The program starts Planar heaters from computer and reads data from the heaters:

- start number,
- current mode of operation,
- software version,
- air inlet temperature in °C,
- supply voltage in V,
- flame indicator value in standard units,
- fuel pump frequency in Hz,
- electric motor speed.

For more information, refer to the instruction manual of the USB adapter.

7 Heater Check after Repair.

7.1 After repair, the heater should be tested for efficiency on the DV1105.000 stand, and after that it can be installed on the vehicle. (The heater can also be tested on the vehicle on which it will be used).

7.2 Connect the heater to a 12 or 24 V power supply (depending on the heater) and to the fuel tank. Then fill the fuel line to the heater by means of a fuel priming device. Start the heater. The heater should start at the minimum power mode which is set by the controller. The heater should operate at the minimum power mode for at least 10 minutes. While changing the power mode of the heater by means of the controller from the minimum to the maximum value, make sure that the intensity of heating increases.

7.3 At maximum power mode, measure the temperature difference between the inlet and the outlet of the heater, the exhaust gas temperature, and carbon monoxide (CO) content. Temperature difference between inlet and outlet should be at least $70\div 90^{\circ}\text{C}$. Exhaust gas temperature should be not more than 500°C . The carbon monoxide (CO) content should be not more than 0.1%. After conducting the measurements, switch off the heater. The LED on the controller will blink frequently, which means that the purging process is underway in the combustion chamber. After purging is finished, the LED will blink infrequently, which means that the heater is not working. When the work is completed, turn off the power and dismount the heater from the test stand.

If in the process of starting or running the heater, there was a crash, for whatever reason, and the heater was turned off, the display panel of the controller will show a fault code. Once the cause of the failure is corrected, the test should be repeated.

When the heater is mounted on the vehicle after the repair, it should be checked for proper operation both with engine off and on.

Attention! The cabin sensor, if installed, should be disabled, if you have to run the heater when the air temperature is more than 30°C .