

D3LC compact Air Heater

Installation
Troubleshooting &
Parts Manual



www.espar.com
inquiries@espar.com

D3LC compact

Heater Models	Release period
12V 25 1906 05	Apr'96 - Mar'97
25 1967 05	Mar'97 - Nov'97
25 1980 05	Nov'97 - Present
24V 25 1907 05	Dec'96 - Feb'97
25 1968 05	Feb'97 - Feb'98
25 1981 05	Feb'98 - Present

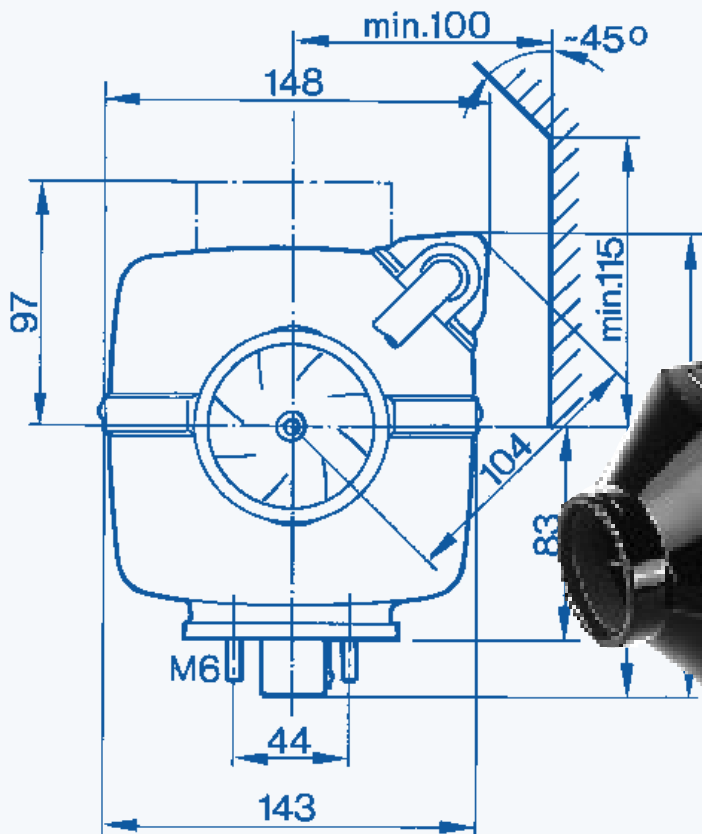

Table of contents		Page#
Introduction	General Specifications	3
	Heater Warnings	4
	Introduction	5
	Principal Dimensions	6
	Mounting Pattern	6
	Heater Components	7
Installation Procedures	Heater Location	8
	Heater Mounting	8
	Heater Air Ducting	8
	Fuel System	10
	Electrical Connections	12
	Exhaust & Combustion Air Intake Connections	13
	Operating Switches	13
Heater Operation	Switch On	14
	Start Up	14
	Temperature Setting	14
	Temperature Control	14
	Switch Off	14
	Controls and Safety Equipment	14
	Operation Flow Chart	15
Maintenance, Troubleshooting & Repairs	Wiring Diagrams - model 25 1980/1981	16
	Wiring Diagrams - model 25 1967/1968	17
	Wiring Diagrams - model 25 1906/1907	18
	Recommended Periodic Maintenance	19
	Basic Troubleshooting	19
	Self Diagnostics	20
	Fuel Quantity Test	24
	Components Specification Chart	24
	Repair Steps	25
Heater Parts	D3LC compact - Service Parts Diagram	28
	D3LC compact - Parts List	32

Special Notes

Note: Highlight areas requiring special attention or clarification.

Caution: *Indicates that personal injury or damage to equipment may occur unless specific guidelines are followed.*

⚠ Warning: Indicates that serious or fatal injury may result if specific guidelines are not followed.

This publication was correct at the time of print. However, Espar Inc. has a policy of continuous improvement and reserves the right to amend any specifications without prior notice.



Heater Warnings

Warning To Installer:

Correct installation of this heater is necessary to ensure safe and proper operation. Read and understand this manual before attempting to install the heater.

Warning - Explosion Hazard

1. Heater must be turned off while re-fueling.
2. Do not install heater in enclosed areas where combustible fumes may be present.
3. Do not install heaters in engine compartments of gasoline powered boats.

Warning - Fire Hazard

1. Install heater so it will maintain a minimum distance of 2" from any flammable or heat sensitive material.
2. Install the exhaust system so it will maintain a minimum distance of 2" from any flammable or heat sensitive material.
3. Ensure that the fuel system is intact and there are no leaks.

Failure to follow these instructions could cause fire resulting in serious or fatal injury.

Warning - Asphyxiation Hazard

1. Route the heater exhaust so that exhaust fumes cannot enter any passenger compartments.
2. Ensure an air tight seal will be maintained between the heater and mounting surface and at any exhaust connection points.
3. Ensure that heating air supply is taken from an area where poisonous gases will not be present.
4. If running exhaust components through an enclosed compartment, ensure that it is vented to the outside.

Failure to follow these instructions could cause oxygen depletion resulting in serious or fatal injury.

Direct questions to Espar Heater Systems

USA	1-800-387-4800
CDA	1-800-668-5676

General Specifications

Heat Output ($\pm 10\%$)	12,000 BTU/hr Boost 11,000 BTU/hr High 5,100 BTU/hr Medium 3,400 BTU/hr Low																		
Current Draw at 12v ($\pm 10\%$)	20.0 amps/hr - Start 3.0 amps/hr - Boost 3.0 amps/hr - High 1.0 amps/hr - Medium 0.7 amps/hr - Low																		
Current Draw at 24v ($\pm 10\%$)	10.0 amps/hr - Start 1.50 amps/hr - Boost 1.50 amps/hr - High 0.5 amps/hr - Medium 0.35 amps/hr - Low																		
Fuel Consumption ($\pm 10\%$)	<table> <thead> <tr> <th></th> <th>U.S.</th> <th>Litre/hr</th> </tr> </thead> <tbody> <tr> <td>Gal/hr</td> <td></td> <td></td> </tr> <tr> <td>Boost</td> <td>.11</td> <td>.42</td> </tr> <tr> <td>High</td> <td>.10</td> <td>.37</td> </tr> <tr> <td>Medium</td> <td>.05</td> <td>.18</td> </tr> <tr> <td>Low</td> <td>.03</td> <td>.12</td> </tr> </tbody> </table>		U.S.	Litre/hr	Gal/hr			Boost	.11	.42	High	.10	.37	Medium	.05	.18	Low	.03	.12
	U.S.	Litre/hr																	
Gal/hr																			
Boost	.11	.42																	
High	.10	.37																	
Medium	.05	.18																	
Low	.03	.12																	
Air Flow ($\pm 10\%$)	78 cfm Boost 78 cfm High 39 cfm Medium 32 cfm Low																		
Operating Voltage Range	10V or 20V (minimum on 12 or 24V system) 14V or 28V (maximum on 12 or 24V system)																		
Overheat Temperature Shutdown ($\pm 10\%$)	240°F (116°C)																		
Ambient Operating Temperature	104°F to 158°F (-40°C to 70°C)																		
Weight	14.3 lbs. (6.5Kg)																		

Note: The heater control unit is equipped with a low voltage cutout to prevent vehicle battery drain and a high voltage cutout to protect heater electrical parts.

Introduction

Espar D3LC Compact Air Heater

The Espar D3LCcompact is a diesel-fired 11,000 BTU/HR air heater, quality engineered to provide a dependable mean space heating in applications such as small cargo, marine cab utilities. This heater is uniquely designed for inside mounting and an easy installation.

The heater provides a comfortable atmosphere for passenger comfort. Since the heater runs on diesel fuel and 12 or 24 volt power, it is able to perform this completely independent of the vehicle engine.

The D3LCc is operated by a rheostat switch or room thermostat. It cycles through four temperature settings (boost-high-medium-low) in order to maintain the desired temperature. In special cases, even less heating capacity is required than the supplies in the "Low" setting, it switches to the "Off" setting.

Temperature and overheat limit switches, and a specially designed heat exchanger are among the safety features which make this heater a safe and dependable unit.

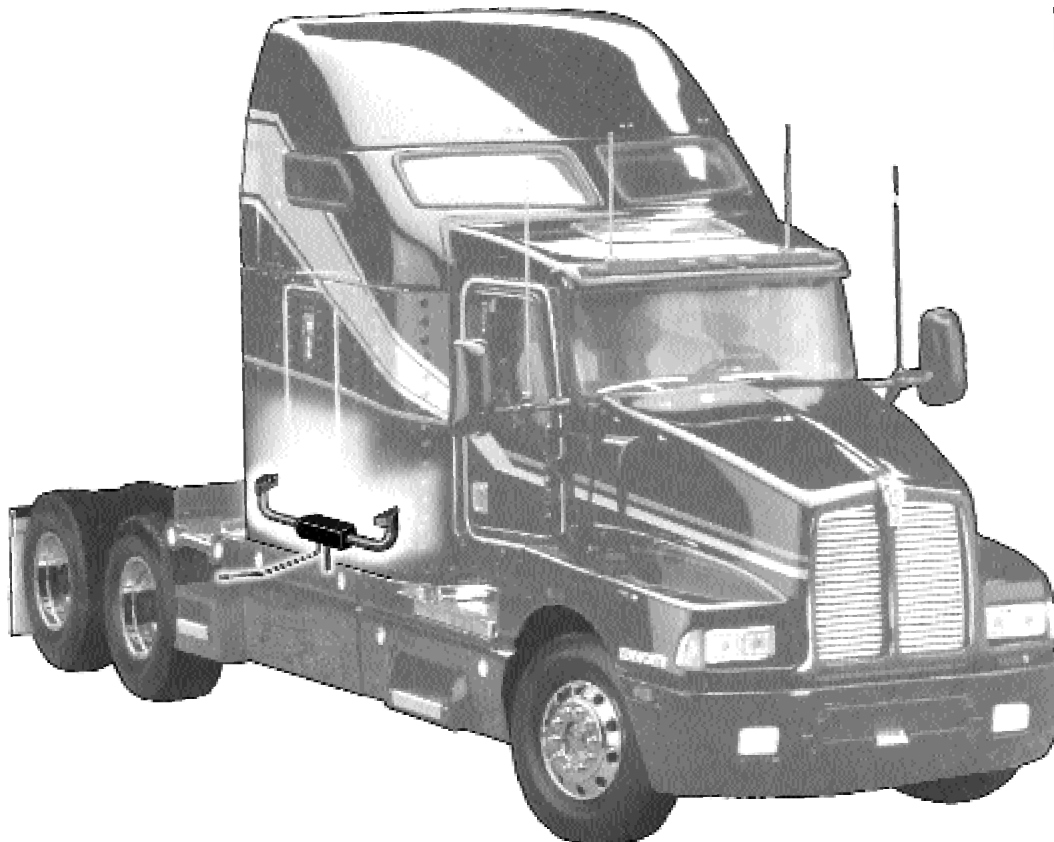
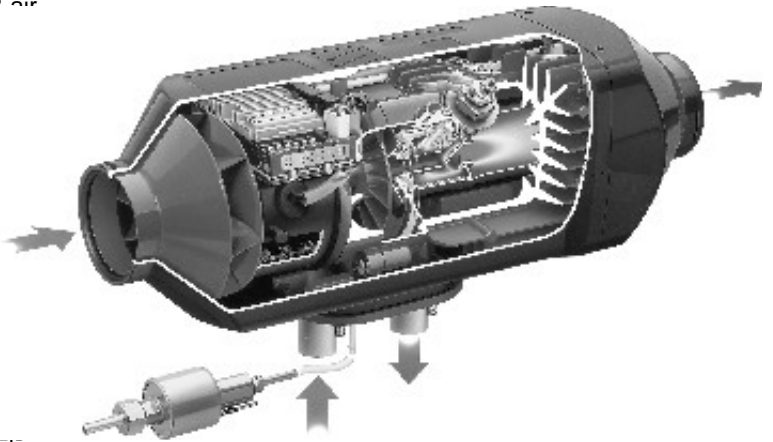

Principal Dimensions

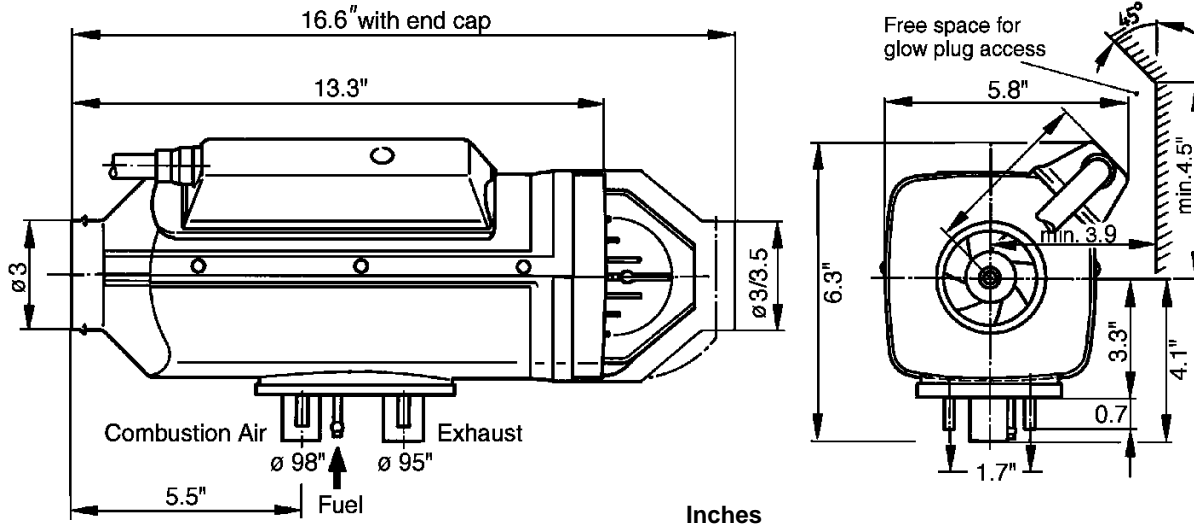

Mounting Pattern

If fastening to the vehicle wall/floor, make penetrations in accordance with the hole pattern shown. A pre-punched mounting kit is also available as shown.

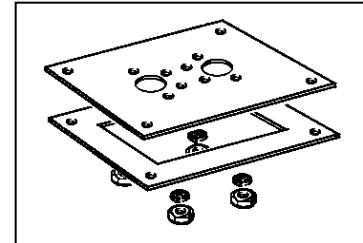

P/N: CA0 00 019

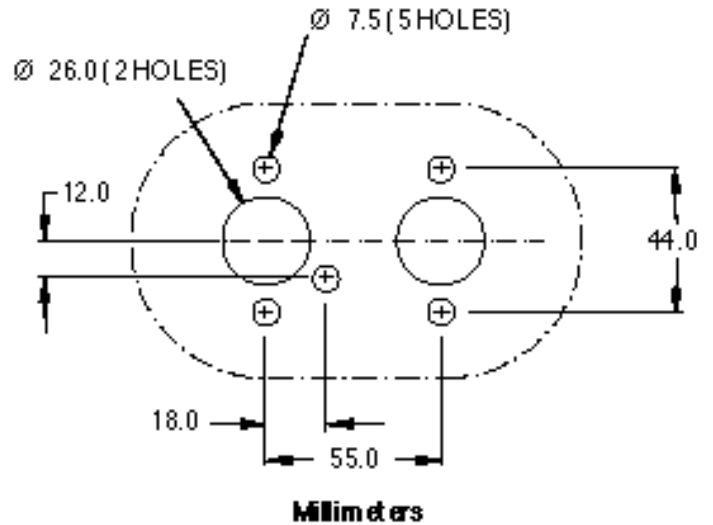
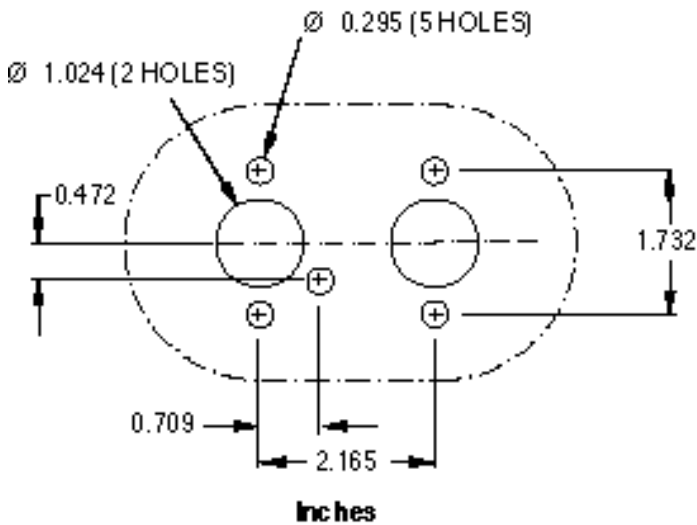

Heater Components

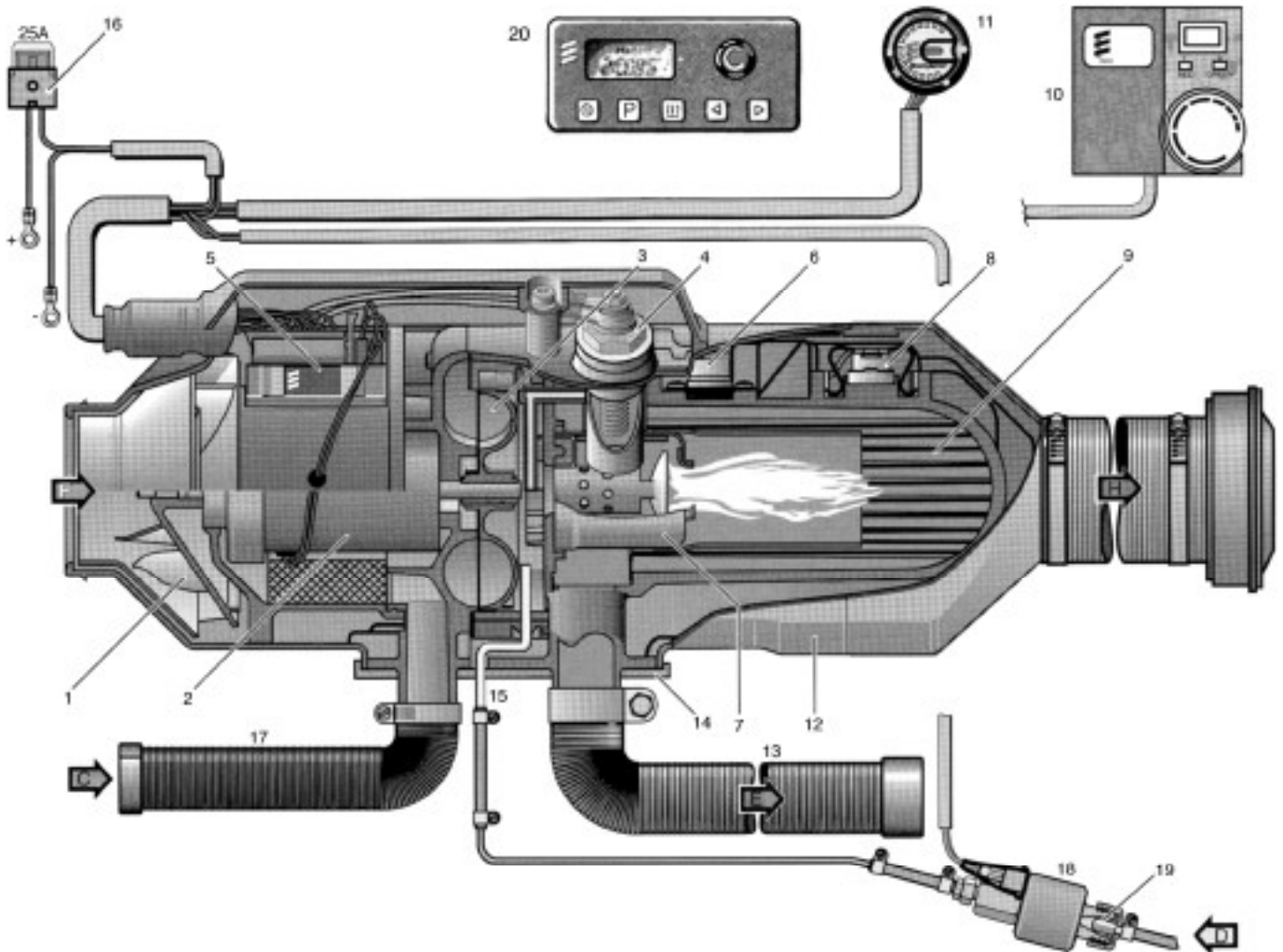

Parts List

- | | |
|--------------------------------|-------------------------------|
| 1 Hot Air Blower Wheel | 11 Operating Unit (Rheostat) |
| 2 Blower Motor | 12 Outer Casing |
| 3 Combustion Air Blower Wheel | 13 Exhaust Line |
| 4 Glow Plug | 14 Flange Seal |
| 5 Control Unit | 15 Fuel Line |
| 6 Safety Thermal Sensor | 16 Main Fuse, 25 A |
| 7 Combustion Chamber | 17 Combustion Air Intake Line |
| 8 Flame Monitor | 18 Fuel Metering Pump |
| 9 Heat Exchanger | 19 Fuel Strainer |
| 10 Operating Unit (Thermostat) | 20 7 Day Timer (optional) |

F = Fresh Air
C = Combustion Air
D = Fuel
H = Hot Air
E = Exhaust

Installation Procedures

Heater Location

Depending on the type of vehicle, the best location for mounting the heater will vary. Typically, heaters are mounted inside tool or luggage compartments. However, the heater may be mounted anywhere inside the vehicle provided you adhere to the following conditions:

- Combustion air intake, exhaust and fuel inlet must be located outside of vehicle.
- Heater must be mounted on flat horizontal surface providing an air tight seal between heater and vehicle.
- Do not mount the heater outside the vehicle, unless care is taken to protect the heater from the weather.

When selecting the location, consider the following:

- Combustion air and exhaust connections.
- Ducting.
- Fuel line connections.
- Electrical connections.

Mounting Plate Installation

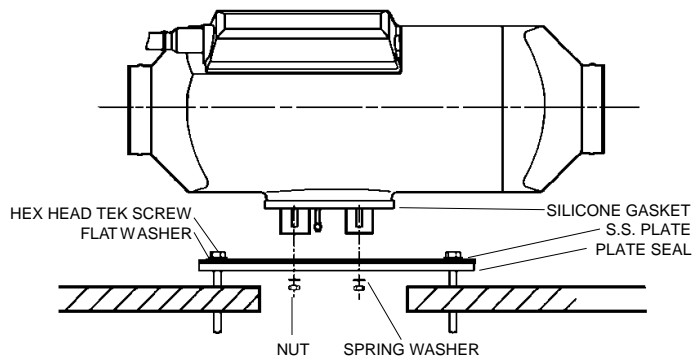

Heater Air Ducting

Installation

A 90mm flexible duct 40 inches long, hot air outlet and clamps are provided with the heater kit. In routing and installing the ducting the following criteria must be observed:

- Run ducting with smooth bends. Avoid crushing duct.
- Position hot air outlet so that it cannot be obstructed.
- Use protective air intake grille on air inlet side of heater to prevent objects from being sucked in.
- Ensure provisions are made for proper air return ventilation.
- Use return air ducting for best heating efficiency

Heater Mounting

Amounting plate and hardware are provided with the heater kit.

- Choose heater location.
- Using template provided, drill and cut center hole. Cut one (1) four and one half inch (4 1/2") diameter hole or one rectangular hole four (4") by five (5") inches.
- Mount heater on mounting plate with nuts and spring washers provided.
- For ease of installation make the exhaust, combustion air intake and fuel connections at base of heater before mounting the heater into the vehicle.
- Position heater in vehicle and secure with "Tek" screws provided.

Note: Tighten screws sufficiently to ensure positive seal between mounting plate and mounting surface. **Do not** over tighten.

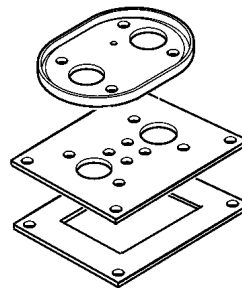

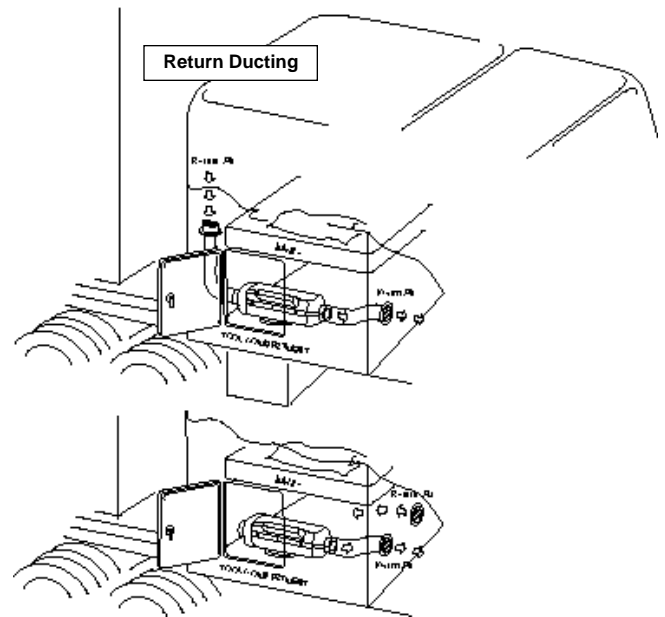
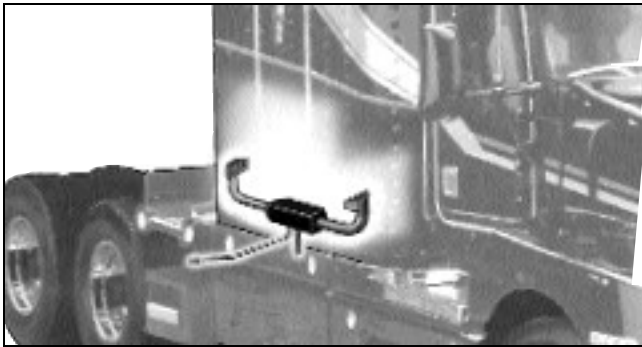

Ducting Components

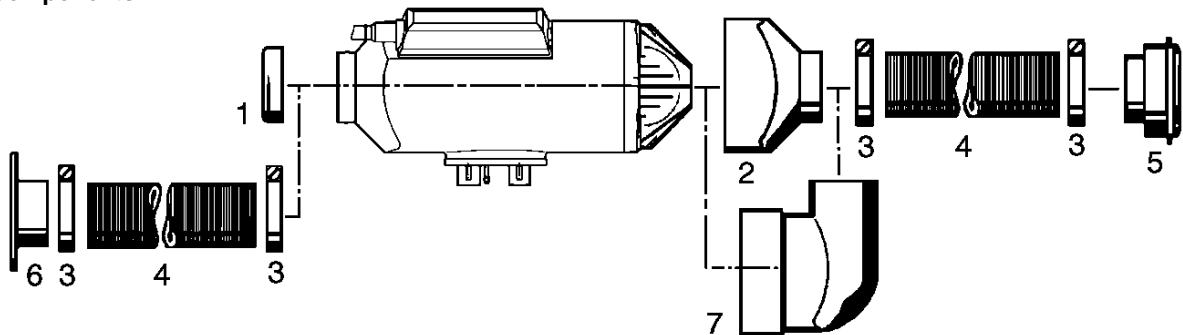

1. Protective Grill
2. Air Outlet Hood

3. Hose Clamp 2-2 3/4"
4. Flex Duct 3" or 90mm

5. Air Outlet - Rotatable
6. Connection Piece

7. 90° Bend Ducting 2 3/8"

Warning:

Do not use existing vehicle ducting or outlets. Ducts and outlets must be capable of withstanding a minimum of 300°F operating temperatures. To avoid exhaust leakage, the heater must always be operated with an end cap installed.

Caution:

Do not over tighten duct clamps.
Do not position outlet so that it will blow hot air directly at operator or at room thermostat.

Fuel System

The fuel metering pump is the heart of the system and must be installed properly to ensure a successful heater operation.

Fuel System Overview

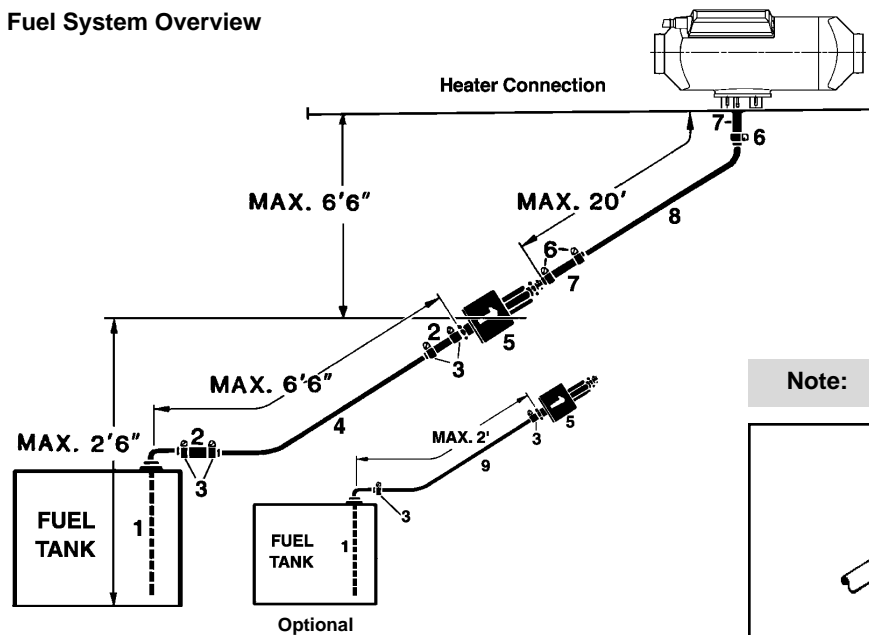

1. Fuel Pick-Up Pipe
2. 5.0 Rubber Connector
3. 11mm Clamp
4. 2.0mm Black Plastic Fuel Line
5. Fuel Metering Pump
6. 9mm Clamp
7. 3.5mm Rubber Connector
8. 1.5mm White Plastic Fuel Line
9. 5mm Rubber Fuel Line

Note: Butt joints and clamps on all connections.

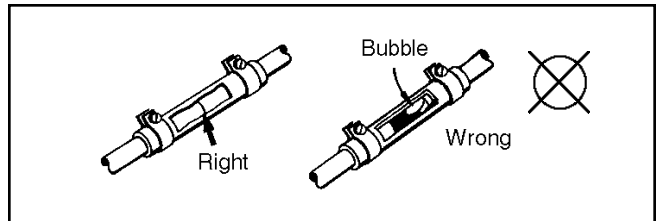

Fuel Pick-Up Pipe Installation (Standard Pick-Up)

- Choose a protected mounting location close to the fuel pump and heater. A spare fuel sender gauge plate provides an ideal mounting location.
- Drill the mounting holes as shown
- Cut the fuel pick-up pipe to length.
- Mount the fuel pick-up pipe as shown.
- Lower the fuel pick-up pipe (with reinforcing washer) into the tank using the slot created by the two 1/4" holes.
- Lift the assembly into position through the 1" hole.
- Assemble the rubber washer, metal cup washer and nut.

Note: Drill the two 1/4" holes first.

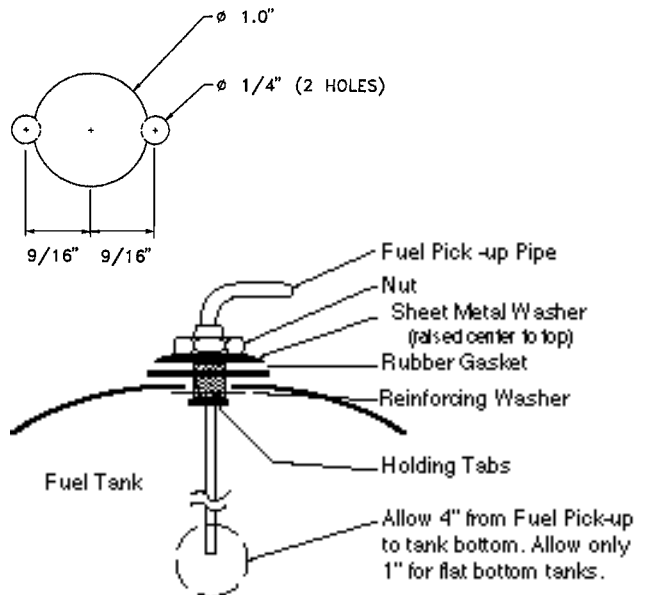

(Custom Pick-Up Pipe with NPT fitting)

- Remove an existing plug from the top of the fuel tank.
- Cut the fuel pick-up pipe to length.
- Secure the fuel pick-up pipe into position using the combined NPT compression fitting as shown.

Note: NPT fittings are available in various sizes (Refer to parts section).

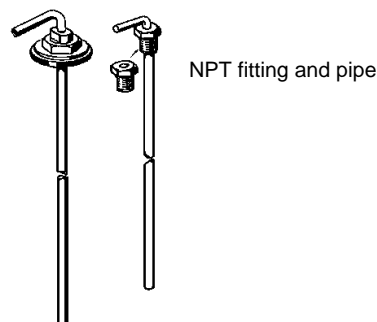



Fuel Metering Pump

- Choose a protected mounting location close to the fuel pick-up pipe and heater.
- Using the bracket and rubber mount provided, install fuel pump as shown

Note: Proper mounting angle of the fuel pump is necessary to allow any air or vapor in the fuel lines to pass through the pump rather than cause a blockage.

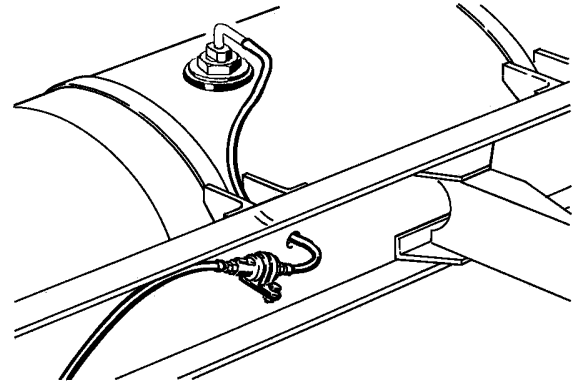

Fuel Line

- Route fuel lines from the fuel pick-up pipe to the fuel metering pump then to the heater.
- Use fuel lines provided.
- Other sizes or types of fuel lines may inhibit proper fuel flow.
- Make proper butt joints using clamps and connector pieces as shown on page 8
- Use a sharp utility knife to cut plastic fuel lines to avoid burrs.

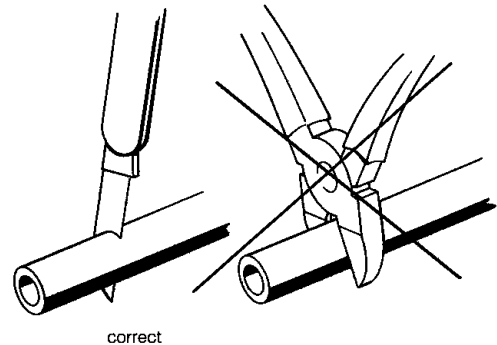
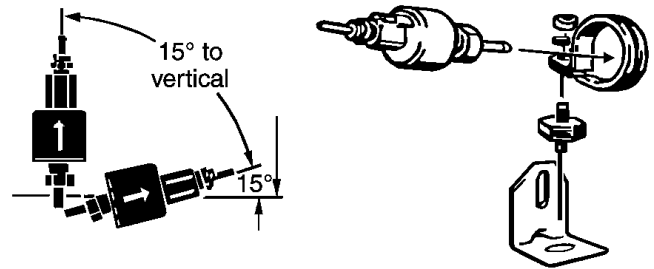

Electrical Connections

Caution:

Install power fuse only after all electrical connections are complete.

Main Harness.....

11 core harness (red/white, green/red, blue/white, red, white, grey/red, grey, brown, brown, brown/white and yellow).
 Connect to heater control unit (mounted in heater) using the 14 pin connector then connect glow plug connector.
 Place protective hood over glow plug and control unit & secure.
 Connect to other harnesses as described for each harness.

Power Harness.....

2 core harness (red and brown).
 Connect red wire to fuse holder near battery.
 Connect red fuse link wire to other side of fuse holder.
 Connect other end of fuse link wire directly to battery positive post using ring terminal provided.
 Connect brown wire directly to battery negative post using ring terminal provided.
 Run power harness to main harness - connect 2 pin connectors

Switch Harness.....

6 core harness (red, brown/white, yellow, grey, brown and grey/red)
 Connect to rheostat switch or thermostat (refer to switch connection section).
 Connect switch harness to main harness using 8 pin connector.

Fuel Metering Pump Harness.....

2 core harness (green/red and brown).
 Connect to fuel metering pump using single terminals and rubber protective boots (no polarity required).
 Connect fuel metering pump harness to main harness using two single connectors.

Electrical Connections

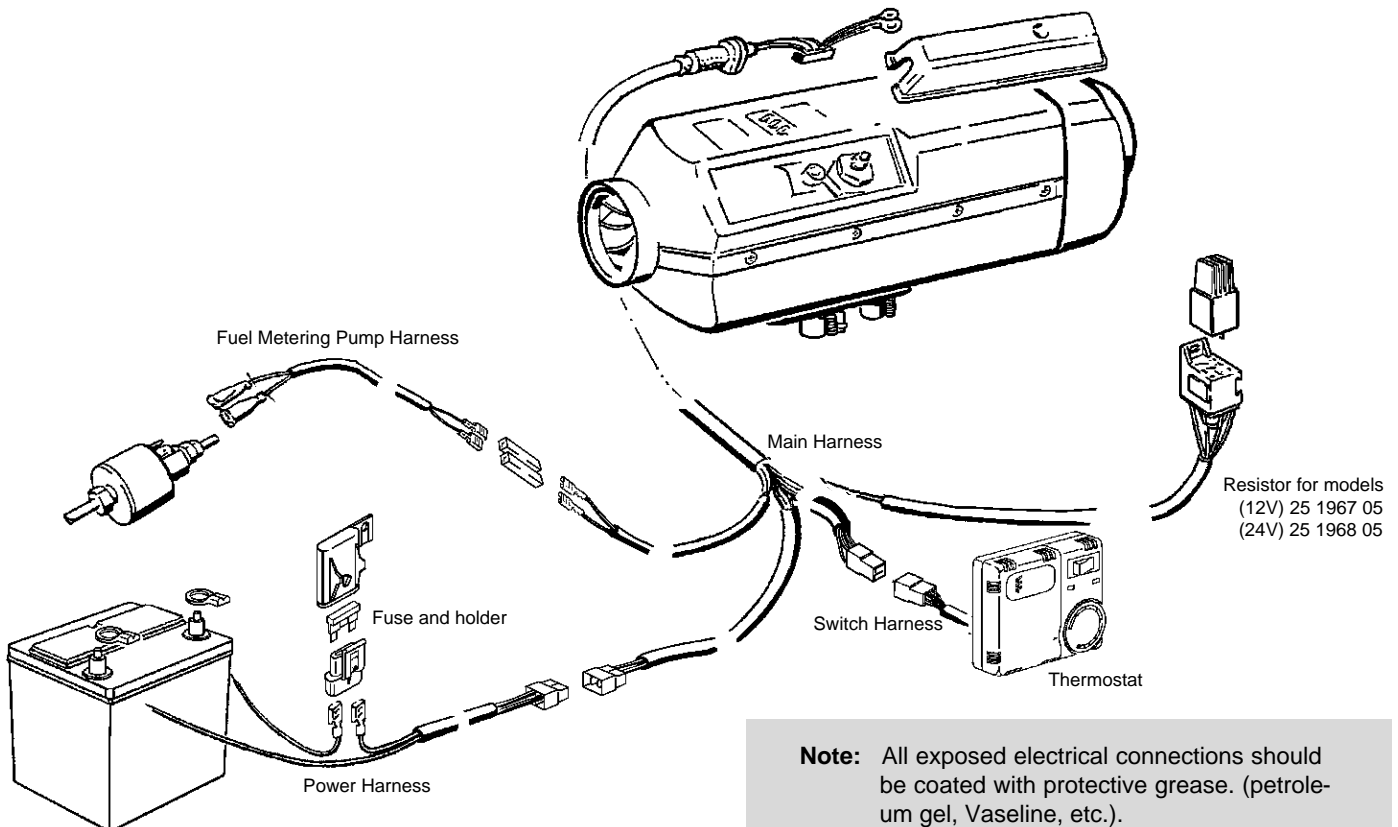



Exhaust and Combustion Air Intake Connections

A 24mm flexible stainless steel exhaust pipe (39" long) and a 20mm flexible plastic tube (39" long) for combustion air intake are included with the heater kit. Exhaust clamps and holders are also provided.

Caution: Run exhaust and combustion air intakes so they cannot be plugged by dirt, water or snow. Ensure the outlets do not face into the vehicle slip stream. Keep exhaust and combustion air intake a minimum of 12" apart. Drill 1/8" holes where necessary to allow water drainage. Balance the exhaust pipe length with the combustion air intake length. Combustion air intake and exhaust lengths can be shortened to a minimum of 8".

- Attach the exhaust pipe to the exhaust outlet of the heat exchanger
- Run to an open area to the rear or side of the vehicle so that fumes cannot build up and enter the cab or the combustion air inlet to the heater.
- Install protective cap.
- Attach the combustion air intake tube to the combustion air inlet of the heater
- Once secure to the heater inlet, the intake pipe must run to the underside of the vehicle where it will pick up clean, fresh, moisture free air.

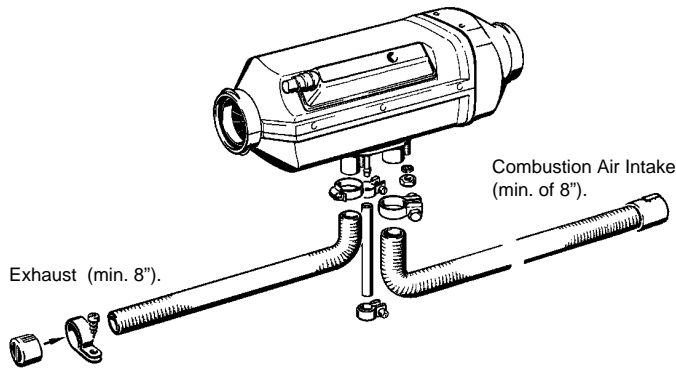

- Warning:** The exhaust is hot, keep a minimum of 2" clearance from any heat sensitive material
- Warning:** Route exhaust so that the exhaust fumes cannot enter the passenger compartment.

Operating Switches

The heater can be controlled using a Thermostat or Rheostat type switch. It can also be accessed by a 7 day timer with thermostat.

Thermostat

- Mount the thermostat in a location where it is easily accessible and it's temperature sensor is representative of the area being heated.
- Mount using the mounting slots in it's base.
- Connect the six core switch harness to the thermostat as shown

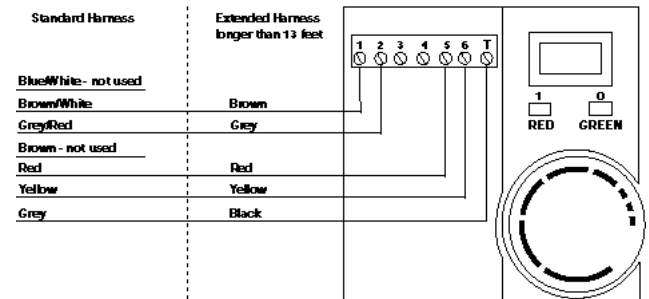

- Brown/White - Power from battery "-"
- Grey/Red - Temperature setting "+"
- Red - Power from battery "+"
- Yellow - Switch control to heater
- Grey - Temperature sensor

Rheostat Switch

Note: When using Rheostat switch, the **Return Ducting** method must be used as shown on page 9. This allows the heater's internal sensor to properly monitor cab temperature.

- Mount the rheostat switch in a location where it is easily accessible.
- Connect the six core switch harness as shown

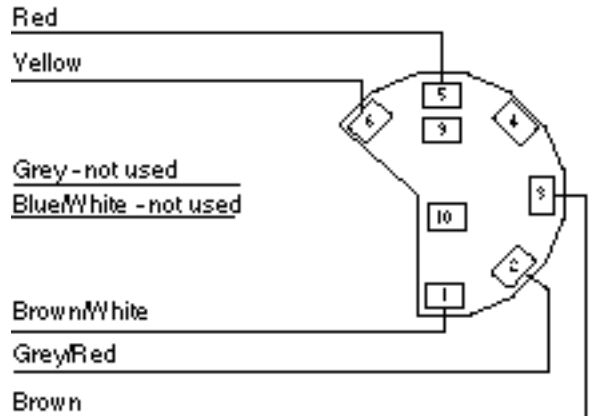
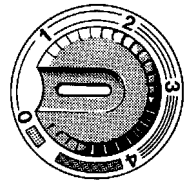

7 Day Timer

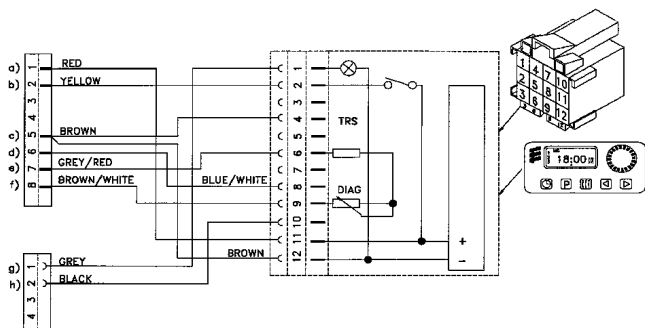

- a - Power from battery “+”
- b - Switch control to heater
- c - Power from battery “-”
- d - Diagnostics from heater
- e - Temperature setting “+”
- f - Temperature setting “-”
- g - Vehicle dimmer switch for light display
- h - Vehicle ignition accessories for continuous operation of heater

Heater Operation

- ⚠ Warning:** To prevent fire, the heater must be switched off while filling fuel tanks. To prevent asphyxiation, the heater must not be operated in enclosed areas

Switch On

- Switch the heater on using the room thermostat's, On/Off switch (1=On, 0=Off) or the rheostat switch.

Start Up

On start up the indicator light illuminates and the following sequences take place:

- Control unit does a systems check (glow plug, flame sensor, temperature sensor, safety thermal sensor).
- Blower starts slowly and begins to accelerate.
- Glow plug is energized and starts preheating the combustion chamber.
- After a short delay (approximately 15 seconds) the fuel pump delivers fuel.
- Ignition will take place as the fuel/air mixture contact the glow plug.
- Blower speed and fuel delivery are slowly increased.
- Once flame is established the glow plug will switch off.
- Heater will begin heating.

Temperature Setting

Using the adjusting dial, set the desired temperature range. From 1-4

- Lowest Setting - approx. 10°C (50°F)
- Mid - Setting - approx. 18°C (65°F)
- Highest Setting - approx. 30°C (85°F)

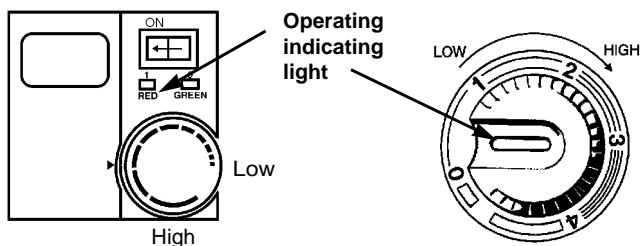

Temperature Control

- The temperature is monitored constantly at the heater intake or thermostat.
- This temperature is compared to the set temperature on the adjusting dial.
- The heater cycles through Boost, High, Medium and Low heat modes to maintain the desired temperature.
- If the desired temperature is exceeded while the heater is operating in low heat mode the heater will switch off. This is a comfort feature.
- The heater will re-start in medium heat mode once heat is again required.

Switch Off

Once switched off either manually or automatically, the heater begins a controlled cool down cycle.





- The fuel pump stops delivering fuel.
- The glow plug is re-energized for a 15 second after-glow.
- The blower continues to run for 3 minutes and automatically switches off.

Controls and Safety Equipment

- If the heater fails to ignite within two 90 second start attempts, a "no start" shut down occurs.
- If a flame out occurs after the heater has started, the heater will attempt to restart.
- If repeated flame outs occur within 10 minutes the heater will not restart.
- Overheat shut down will occur if there is a restriction of the heating air flow (i.e. blocked inlet or outlet). The overheat switch will automatically reset once the heater has cooled down. Once the air flow restriction is removed, the heater can be re-started by switching the heater off then back on.
- If the voltage drops below 10.5 volts or rises above 15.9 volts the heater will shut down (21volts and 30 volts for 24 volt systems).
- If the glow plug circuit or fuel metering pump circuit are interrupted the heater will not start.
- The blower motor is checked on start up and every 4 minutes. Shut down will occur if the blower does not start or maintain proper speed.



Operational Flow Chart

Operating Mode	STARTING PHASE					RUNNING PHASE		SHUT DOWN PHASE		
	System Check	Pre-heat	Ignition Attempt	Pre-heat 2nd. attempt	Ignition Attempt 2nd. attempt	Boost	Controlled Heating	After Glow	Cool Down	Off or Stand by
 Blower	Off	On	On	On	On	On	On	On	On	Off
 Glow Plug	Off	On	On	On	On	Off	Off	On	Off	Off
 Fuel Pump	Off	Off	On	Off	On	On	On	Off	Off	Off
 Time	1- 3 sec.	15 sec.	Up to 90 sec.	15 sec. If Required	Up to 90 sec.	Time dependent on heat exchanger temperature	Continual Operation until switched off by operator or temperature control	15 sec.	3 min.	

Note: During controlled heating cycle, if desired heat level is exceeded the heater will cycle off.
Heater will automatically restart in medium mode once heat is again required

Wiring Diagram
D3LCcompact

Glow plug positive pulsed

Models: 25 1980 05 (12v)
25 1981 05 (24v)

- 1.1 Blower Motor
- 1.2 Glow Plug
- 1.5 Safety Thermal Sensor
- 1.12 Flame Monitor
- 2.1 Control Unit
- 2.2 Fuel Metering Pump
- 3.1.11 Rheostat
- 3.5 Thermostat
- 5.1 Battery

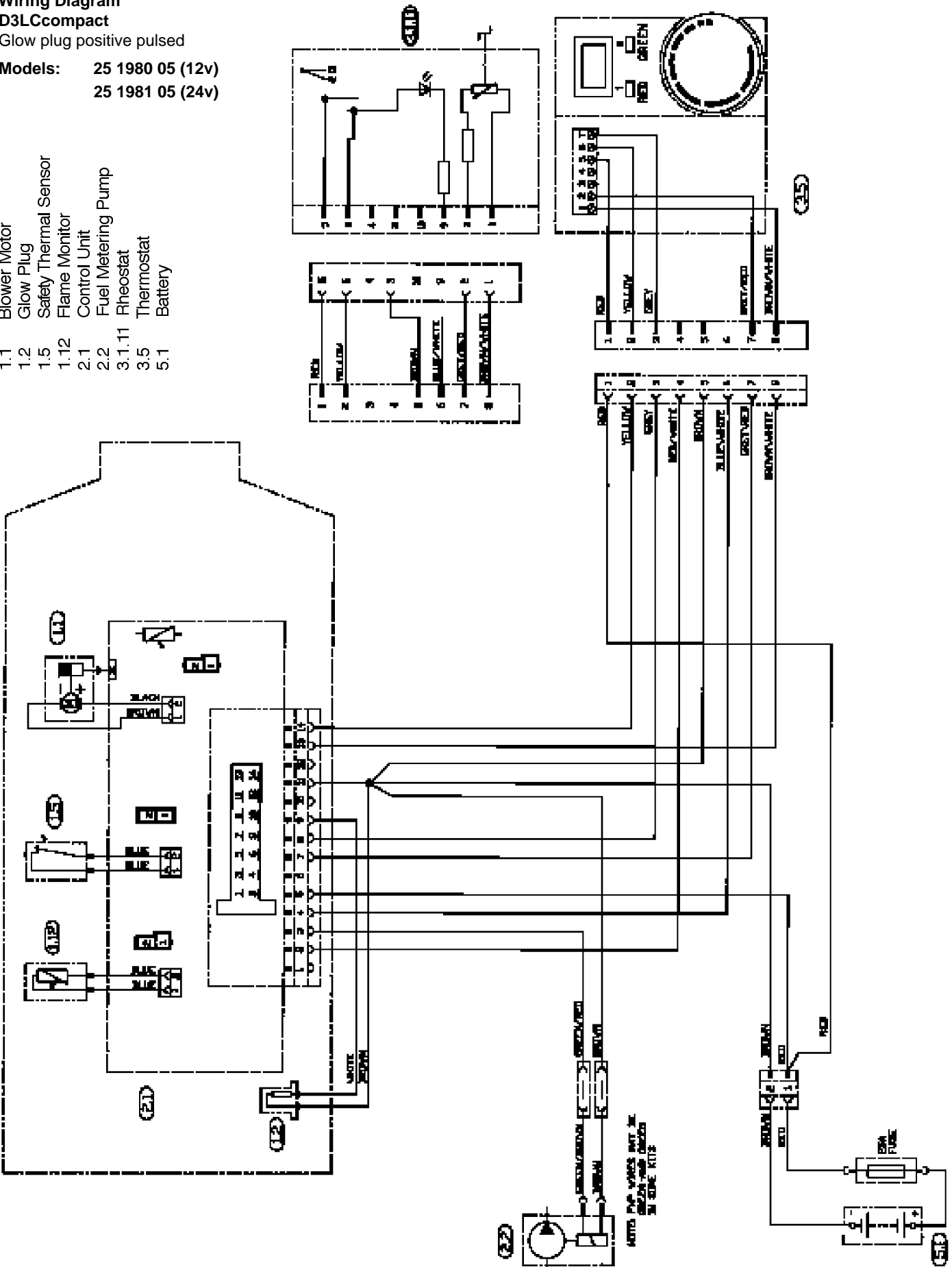



Wiring Diagram
D3LCcompact

Glow plug positive pulsed with current regulator

Models: 25 1967 05 (12v)
25 1968 05 (24v)

- 1.1 Blower Motor
- 1.2 Glow Plug
- 1.5 Safety Thermal Sensor
- 1.12 Flame Monitor
- 2.1 Control Unit
- 2.2 Fuel Metering Pump
- 2.4 Current Regulator
- 3.1.11 Rheostat
- Thermostat
- 5.1 Battery

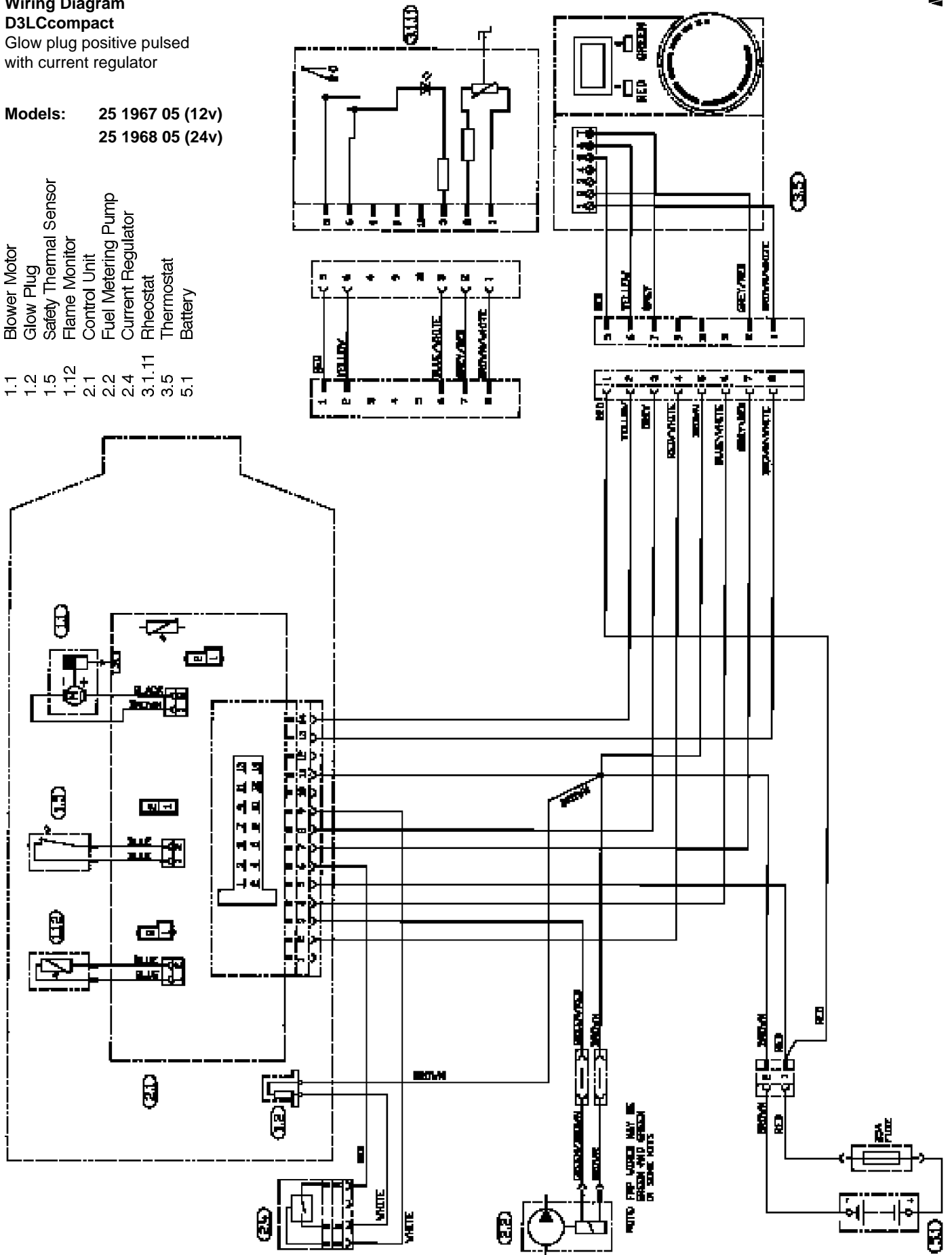

Wiring Diagram

D3LCCcompact

Glow plug negative pulsed

Models: 25 1906 05 (12v)
25 1907 05 (24v)

- 1.1 Blower Motor
- 1.2 Glow Plug
- 1.5 Safety Thermal Sensor
- 1.12 Flame Monitor
- 2.1 Control Unit
- 2.2 Fuel Metering Pump
- 3.1.11 Rheostat
- 3.5 Thermostat
- 5.1 Battery

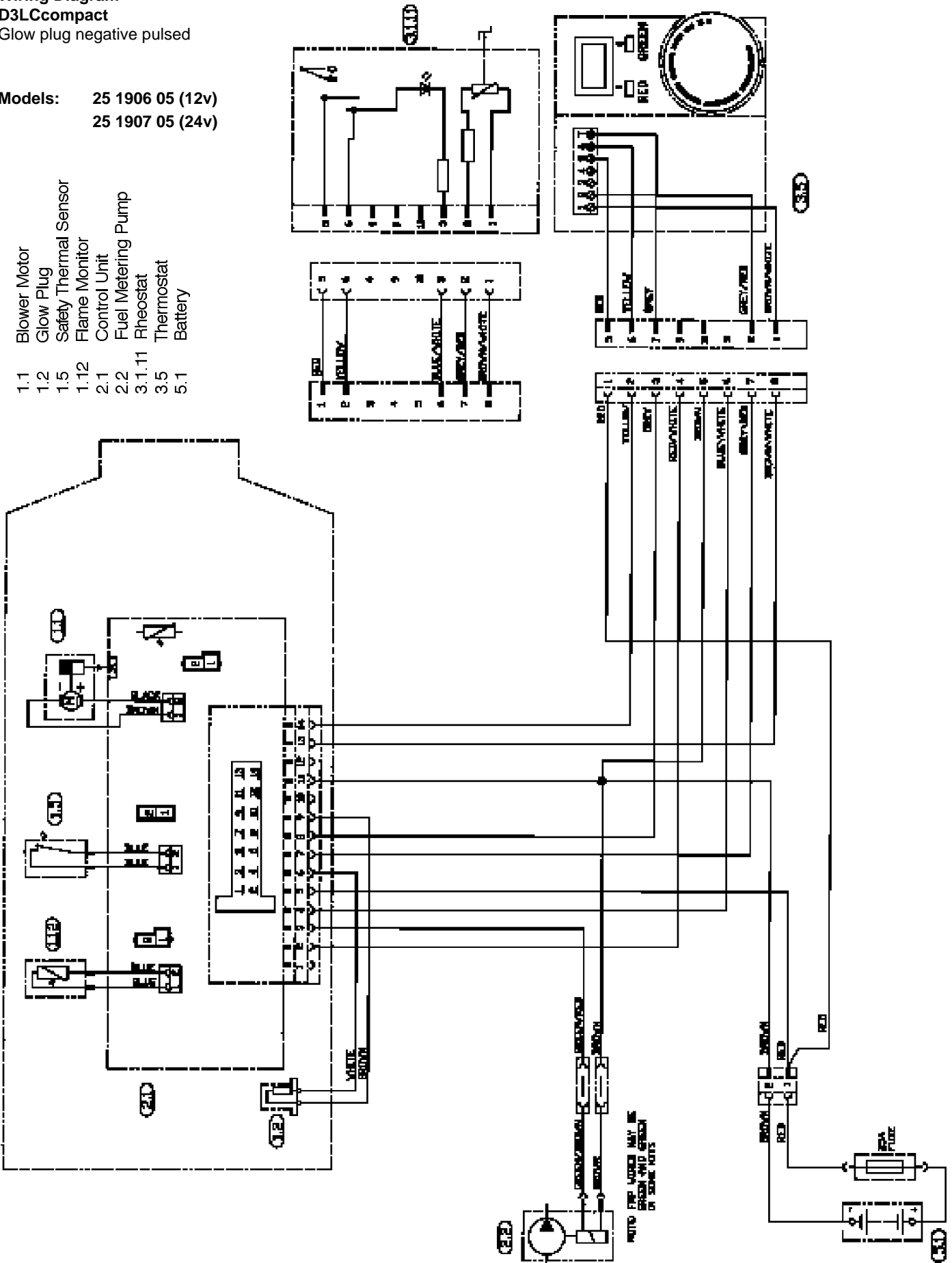



Maintenance, Troubleshooting and Repairs

Recommended Periodic Maintenance

- Remove the glow plug and inspect for carbon build up. Clean or replace.
- Remove the glow plug screen and inspect for carbon build up. Clean or replace. If cleaning is required, use brass brush (Espar part number CA0 05 003).
- Make sure vent hole is open. Espar recommends the use of non detergent 100% volatile carburetor cleaner and an air gun will also help. Remove loose carbon from the glow plug chamber.
- Inspect the ducting, the air intake screen and air outlet for restriction or blockage.
- Inspect combustion air intake and exhaust for blockage.
- Run your heater and check for proper operation during regular preventative maintenance throughout the year.
- Maintain your batteries and all electrical connections in good condition. With insufficient power the heater will not start. Low and high voltage cutouts will shut the heater down automatically.
- Use fuel suitable for the climate (see engine manufacturers recommendations). Blending used engine oil with diesel fuel is not permitted.



Basic Troubleshooting

Check List:

What happens when the heater is switched on and

Heater does not ignite

Blower motor does not run

- Check:**
- Fuse in power harness.
 - Power to control unit.
 - Power to switch.
 - Electrical connections.

Blower motor runs approximately 20 seconds and then shuts off

- Check:**
- Ensure voltage at control unit remains above 9.5 volts during start up with glow plug circuit on.

Blower motor runs/fuel metering pump starts and then shuts down after two 90 second start up cycles

- Check:**
- Fuel lines and fuel filter.
 - Fuel quantity.
 - Combustion air or exhaust tube blockage.

Blower motor runs/no fuel metering pump

- Check:**
- For electrical pulses at fuel metering pump.
 - If pump is frozen.
 - Blocked fuel line.

Heater ignites

Shuts down at random

- Check:**
- Fuel metering pump quantity.
 - Possible overheating.
 - Control unit input voltage.

Heater smokes and carbons up

- Check:**
- Exhaust pipe blocked.
 - Combustion air intake blocked.
 - Exhaust entering combustion air intake pipe.
 - Short cycling, rapid on/off operation.
 - Fuel system.
 - Fuel metering pump quantity.
 - Motor rpm.

Self Diagnostics

The heater is equipped with self diagnostic capability. To retrieve information on the heaters last 5 faults, a retrieval device is required (part # CA1 05 020).

Connect the fault code retrieval device as shown

Equipment Face and Controls

Symbols that are seen on the display face are as follows:

AF	Actual fault.
F1-F5	Up to five stored faults can be accessed. The AF and F1 are the same number.
	This sign is displayed when the heater is in operation.
DIAG	The word (Diagnostic) will come on when the diagnostic number is requested.
000	Three digit diagnostic fault code number.

Retrieval Device
P/N: CA1 05 020

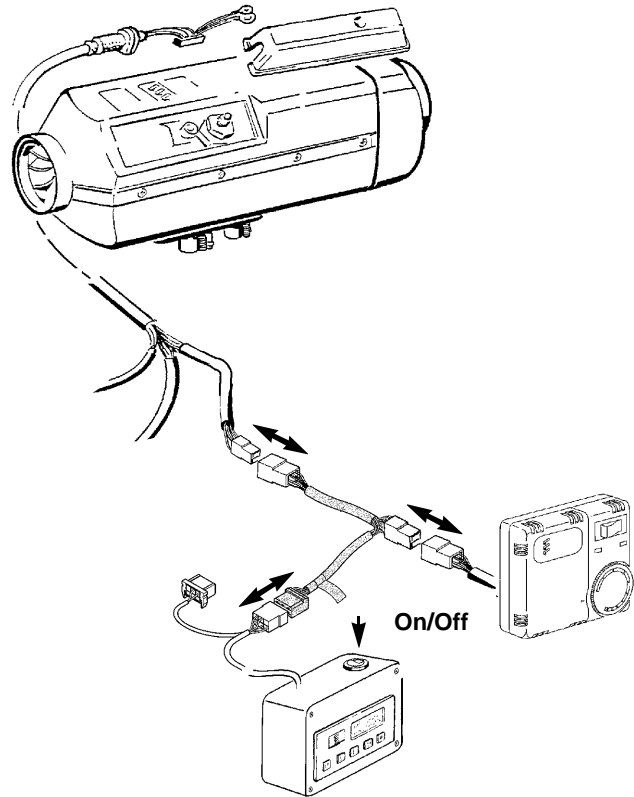
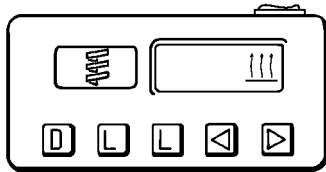

Retrieval Device
P/N: CA1 05 020

- Switch the fault code retrieval device on and wait 10 seconds.
- Press the "D" button.
- Wait 3-5 seconds for the current fault code to appear (AF).
- To review the previous faults use the arrow buttons (F1= Most Recent, F5= Oldest).
- To erase the faults that are in memory press both "L" keys at the same time.
- Consult the fault code chart for code number descriptions.



Note: If there are no heater faults, the heater will go through a normal start cycle and regulate based on thermostat setting.

Fault Code	Fault Description	Causes / Repair
000	Normal Operation	
001	Warning - overvoltage	Check vehicle charging system.
002	Warning - undervoltage	Check batteries and connections.
004	Warning - short in blower signal	Check for short between pin 1 to blower relay. If no short exists replace control unit.
005	Warning - short circuit in anti-theft alarm output	Check for short between pin 2 and alarm relay.
009	TRS - shut down	Check for change of signal from (+) to (-) at pin 10 or a (+) signal at pin 12.
010	Overvoltage	Check voltage between terminals 5 and 11 on control unit. This must be less than 15.9 volts or [31.8] (15.2 [30.4] volts with glow plug on). Check vehicle charging system. *[24V systems]
011	Undervoltage shut down	Check voltage between control unit pins 5 and 11. This must be greater than 10.5 volts (9.5 volts with glow plug on). Check batteries and connections.
012	Overheat	Check for possible causes of overheat. Check overheat switch resistance values.(see component value chart).
013	Overheat at flame sensor	Flame sensor senses temperature above 340°C (resistance value above 2270). Check flame sensor resistance values and overheat switch resistance values (see component value chart).
015	Too many overheats	Control unit limits heater to 3 consecutive overheats (fault code12,13). Remove cause of over heat. Reset control unit using control unit tester or fault code retrieval device to unlock control unit.
020	Open circuit - glow plug	Check glow plug for break in coils. Check resistance across glow plug leads (1-2). Check for continuity between pins 6 and 9. If afore mentioned checks okay, replace control unit.
021	Short circuit - glow plug	24 volt equipment only. A 12V glow plug is fitted. test glow plug for short circuit or examine for carbon deposits on element. Change if necessary.

Fault Code	Fault Description	Causes / Repair
025	Diagnostics output short	Check for short between pin 4 and diagnostics output connection.
033	Burner motor speed deviation	Motor speed varies from specification by more than 10% for longer than 30 seconds. If too slow, check for restriction, and check for short in motor circuit or control unit. If none found, replace blower. If too fast, check for damage to magnetic sensor control on control unit. Replace blower motor if damaged. Replace control unit otherwise.
047	Short circuit - fuel metering pump	Check for short between pin 3 and fuel metering pump. Test fuel metering pump.
048	Open circuit - fuel metering pump	Check for open circuit between pins 3 at control unit and fuel metering pump.
050	Too many no start attempts	Control unit restricts heater to 10 start attempts (20 starts if no flame is detected during start attempts). Check fuel, glow plug, combustion air and exhaust flow. Use control unit tester or fault code retrieval device to unlock control unit.
051	Faulty flame recognition	Allow heater to cool 15 minutes then try restart. Resistance value at flame sensor > 57°C (1220) Check flame sensor resistance value.
052	No start safety time exceeded	No flame detected on start attempt. Temperature at flame sensor <100°C(1380). Check flame sensor resistance values. Check fuel, glow plug, combustion air and exhaust flows.
053	Flame cutout in boost mode	Heater has started successfully the flame has extinguished.
054	Flame cutout in high mode	Check fuel supply. Check combustion air and exhaust flow.
055	Flame cutout in medium mode	If combustion is O.K., check flame sensor resistance value
056	Flame cutout in low mode	check flame sensor, replace if necessary.
060	Open circuit - external temperature sensor	Temperature sensor detects a value beyond it's range. Check connections.
061	Short circuit - external temperature sensor	Check sensor resistance values between pins 8 &13. >2800 - open circuit <280 - short circuit
062	Open circuit - set point potentiometer (control switch)	Potentiometer values outside of range Check resistance between pins 7 and 13.
063	Short circuit - set point potentiometer (control switch)	>2800 - open <280 - short Normal range 1750 - 2080 (+/- 80).
064	Open circuit - flame sensor	Sensor is sensing value outside of range
065	Short circuit - flame sensor	>3200 - open <200 - short



Fault Code	Fault Description	Causes / Repair
071	Open circuit - overheat sensor	Overheating sensor signals values outside of range.
072	Short circuit - overheat sensor	Check connecting leads. >3200 - open circuit <200 - short circuit. See sensor values on next page
090	Control unit defect	Internal failure in microprocessor. Replace control unit.
091	External voltage disturbance	Check vehicle charging system.
092	Control unit defective	Internal failure in microprocessor. Replace control unit.
093	Control unit defective	RAM fault
094	Control unit defective	EEPROM fault
096	Control unit defective (internal temperature sensor)	Internal failure. Replace control unit or use external temperature sensor.
097	Control unit defective (power failure)	Internal failure. Replace control unit.

Fuel Quantity Test

The fuel quantity should be tested if the heater has difficulty starting or maintaining a flame:

Preparation

- Detach the fuel line from the heater.
- Insert the fuel line into a measuring glass (20 cm³ size).
- Switch the heater on and allow fuel system to bleed out air for approx. 25 seconds.
- Switch the heater off and empty the measuring glass.

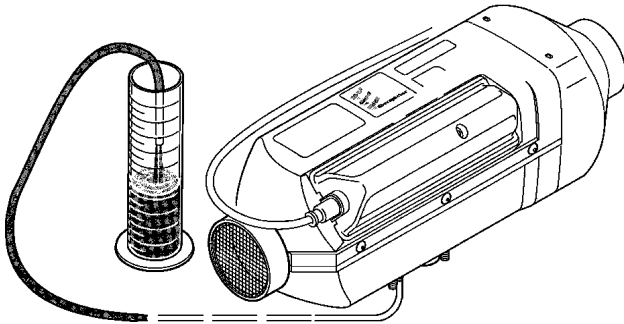

Measurement

- Switch heater on.
- Hold the fuel line in the measuring glass while fuel is being delivered. Hold the graduated measuring glass at glow plug height during measurement
- The pump will stop automatically after delivering fuel for 90 seconds.
- Once fuel pump stops, switch heater off. A restart will occur if heater is not shut off.

Evaluation

- Read the amount of fuel delivered.
- Fuel quantity should be between 7.1 cm³/90 seconds and 9.5 cm³/90 seconds
8.3 cm³/90 seconds is the nominal value
- If the fuel quantity is outside this range, check for and remove any restriction in fuel system or replace the fuel metering pump. (Check screen in suction side of pump)

Note: The fuel quantity is not affected by voltage variances.

Component Specification Chart

Component values given are reference numbers only (at room temperature). Actual component values may vary $\pm 10\%$.

Motor Speeds

Boost	4,200 RPM	
High	4,200 RPM	
Medium	2,200 RPM	
Low	3,000 RPM	
Recirculation	1,000 RPM	(when using internal temperature sensor)
	0 RPM	when using external temperature sensor)

Resistance Values

Metering pump 12V	approx. 10
Metering pump 24V	approx. 36
Glow Plug 12V	approx. 0.6
Glow Plug 24V	approx. 2
Operating control/setpoint pot.	1740-2180 (± 80)

Exhaust Gas

- CO₂ concentration in exhaust gas when heater is running in High heat mode 9-11%.
- Smoke test value from exhaust gas when heater is running in High heat mode <4.

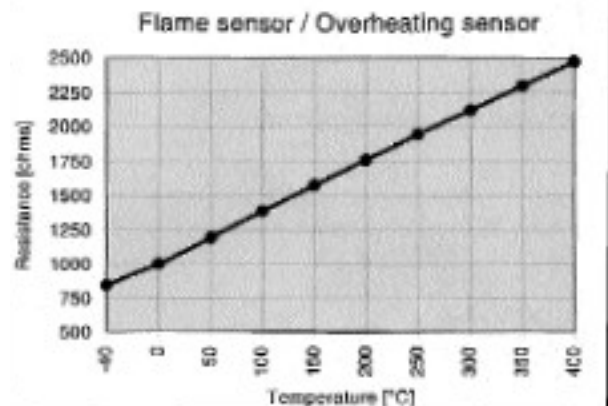
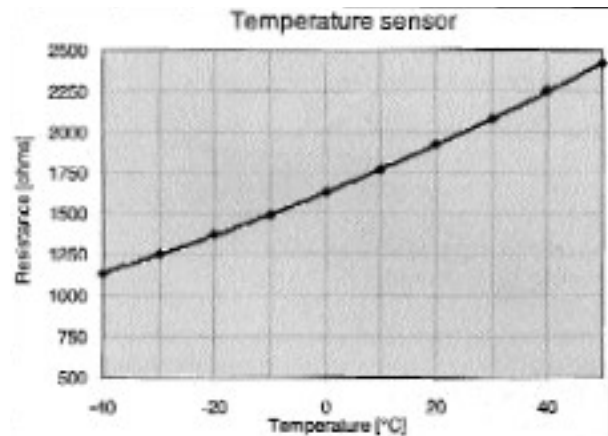



Repair Steps

Inspection, Removal and Replacement of the:-

Glow Plug

Atomizer Screen

Control Unit

Heater Casing Disassembly

Overheat Sensor

Flame Sensor

Blower Removal and Replacement

Heat Exchanger Cleaning

Glow Plug Removal, Inspection and Replacement

- Remove glow plug connector.
- Remove glow plug.
- Inspect coils for carbon build up, breaks or metal fatigue.
- Clean or replace if necessary.
- Re-install in reverse order using a new gasket.

Atomizer Screen Removal, Inspection and Replacement

- Remove atomizing screen using the metal tab and a pair of pliers.
- Clean screen using varsol, brass wire brush and compressed air.
- Inspect screen for deterioration and replace if necessary.
- Clean the glow plug chamber to remove carbon build up.
- Ensure air vent hole and fuel port are clear.
- Re-install fuel screen.

Note: Ensure seam of screen and tab do not block the air vent hole or fuel port.

Control Unit Removal and Replacement

- Unplug main harness and motor connectors. (1)
- To remove Control Unit, unlock and slide out. (2)
- Unplug overheat switch & flame sensor connectors. (3)
- Re-install in reverse order.



Caution: Remove power from the heater prior to any disassembly by unplugging main connection or removing main fuse.

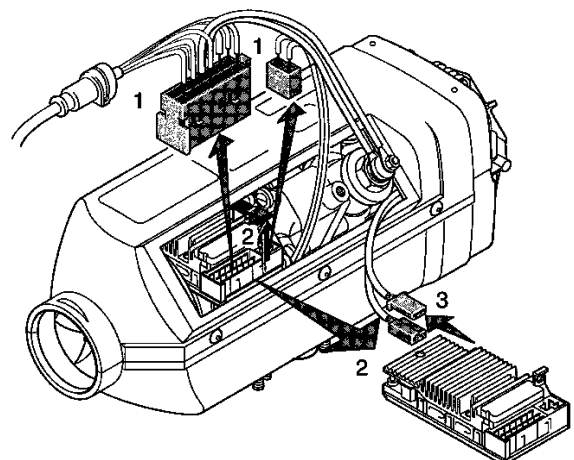
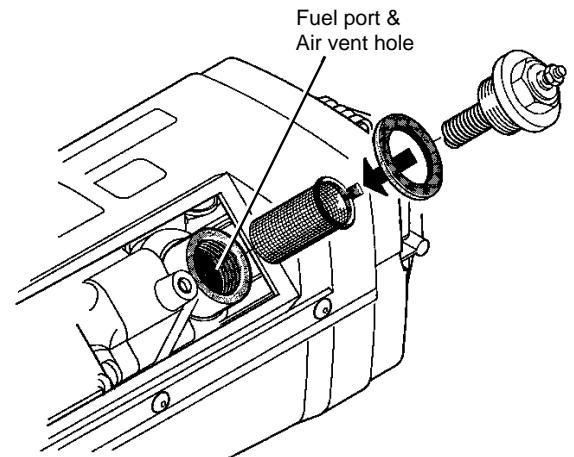
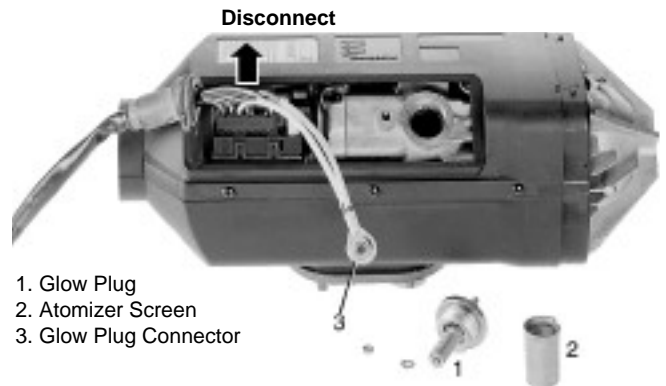

Heater Casing Disassembly

- Remove internal hex screw and cap.
- Pry off air outlet hood using a flat screw driver.
- Remove rivets by punching center pin through and prying out base.
- Remove rubber seal at base of heat exchanger.
- Separate outer casing.
- Re-assemble in reverse order using new rivets.



- 2. Air Outlet Hood
- 3. Cap with Internal Hex Screw

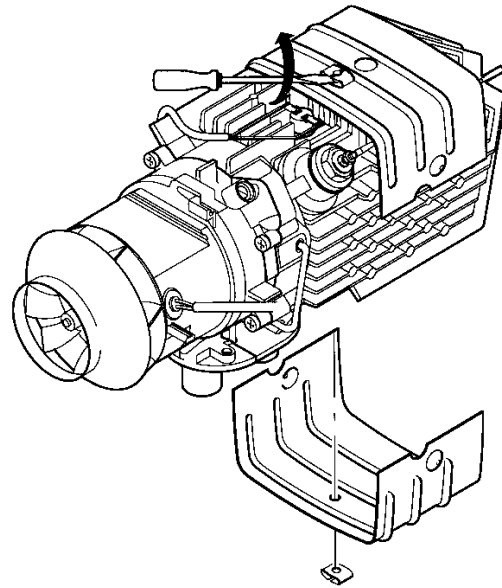
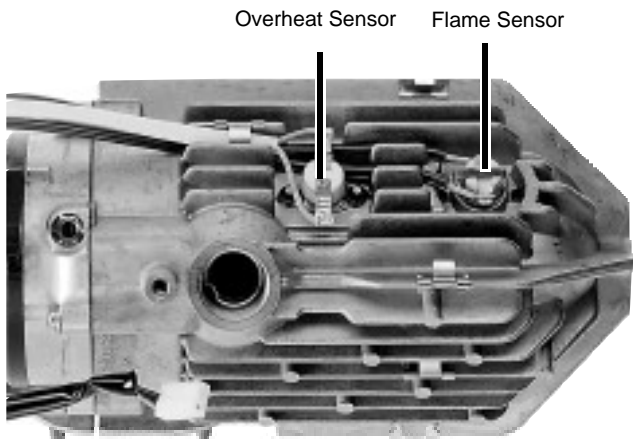
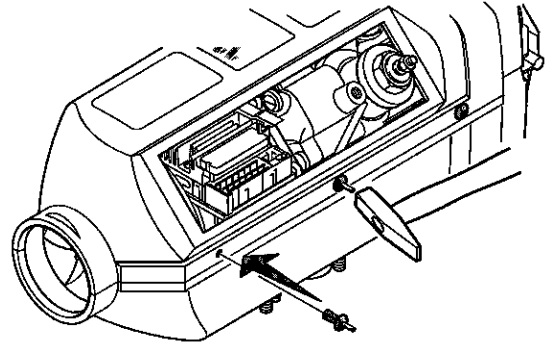
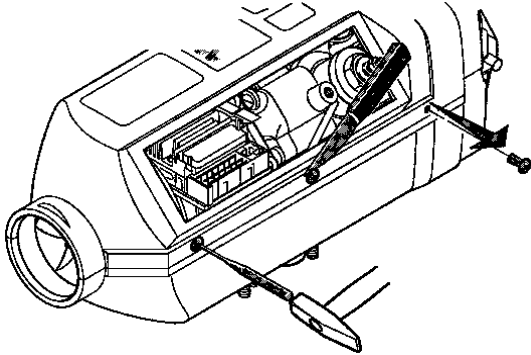

- Release Duo-Clip locking devices with a screw driver and detach insulating brackets.
- Use new locking devices when installing

Overheat Sensor Replacement

- Using a small flat screw driver, pry off holding clips.
- Lift sensor from mounting studs.
- Install replacement sensor using new holding clips.
- Ensure the sensor is securely mounted against heat exchanger.

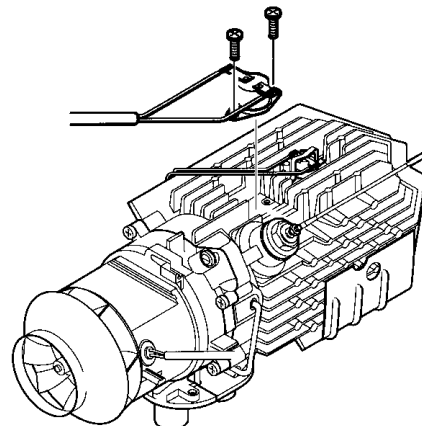



Flame Sensor Replacement

- Using a small flat screw driver, pry off holding spring.
- Remove spring and flame sensor.
- Install replacement sensor using a new mounting spring.
- Ensure the sensor is securely mounted against heat exchanger

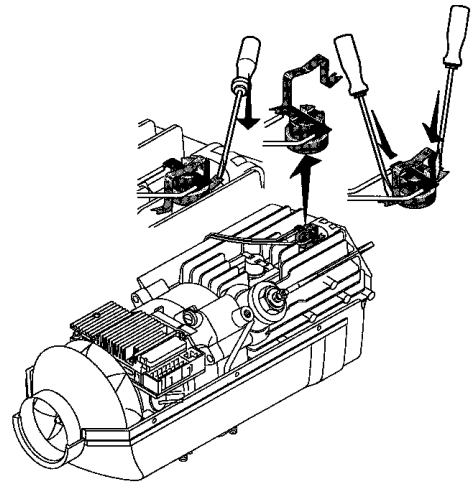

1. Blower
2. Heat Exchanger
3. Gasket

Air Blower

- Remove four mounting screws.
- Separate blower from heat exchanger.
- Re-assemble using new gasket.

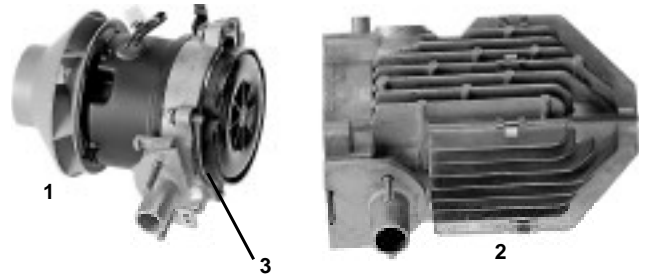

Heat Exchanger

- Remove two mounting screws and baffle plate.
- Remove and replace gasket.
- Clean excessive carbon from inside heat exchanger using a brass wire brush, varsol and compressed air.
- Inspect felt ring and replace if damaged.
- Re-assemble in reverse order using new gaskets.

1. Baffle Plate
2. Gasket
3. Seal Ring

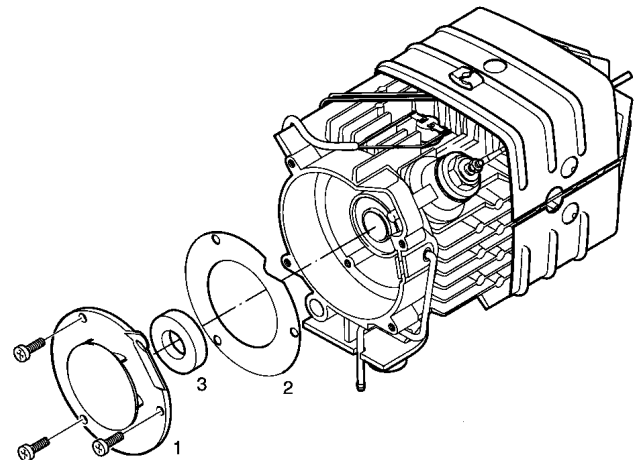
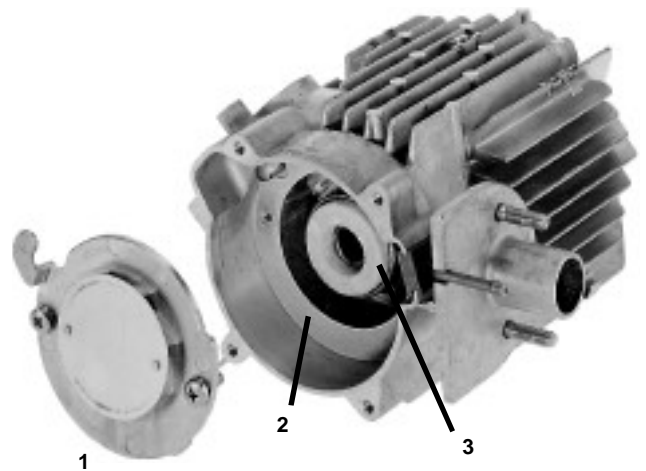

Parts Diagram
D3LCcompact

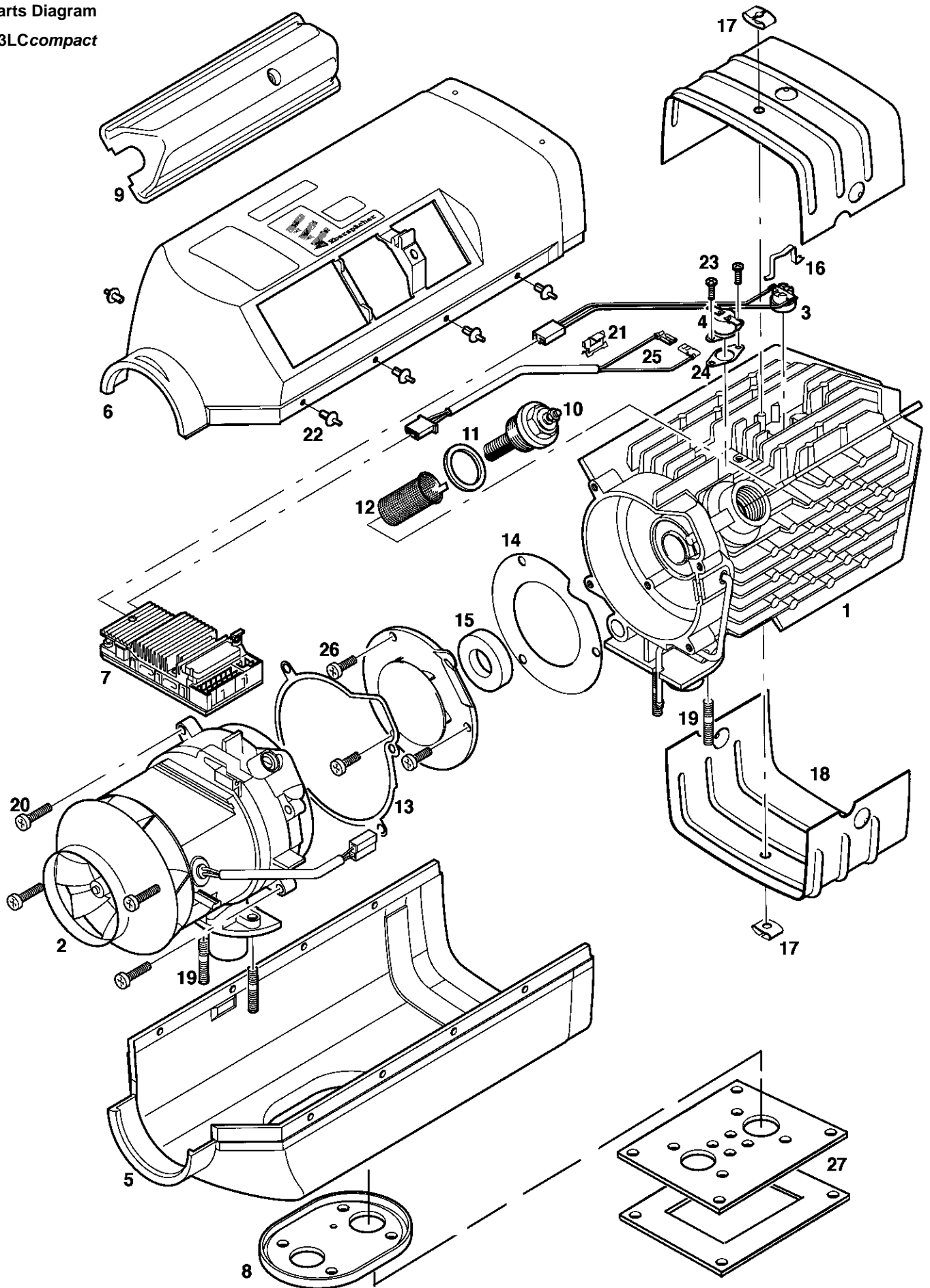

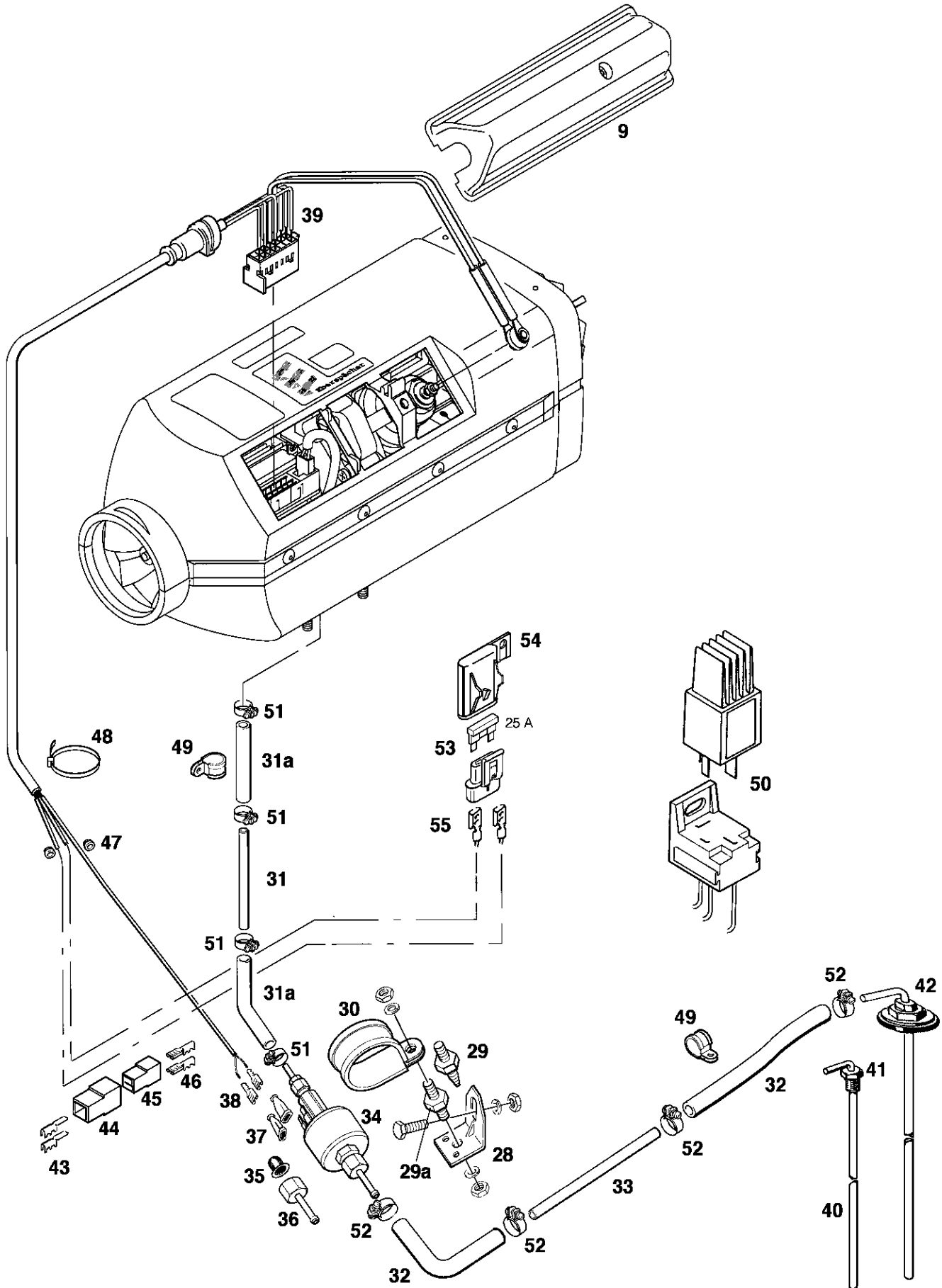

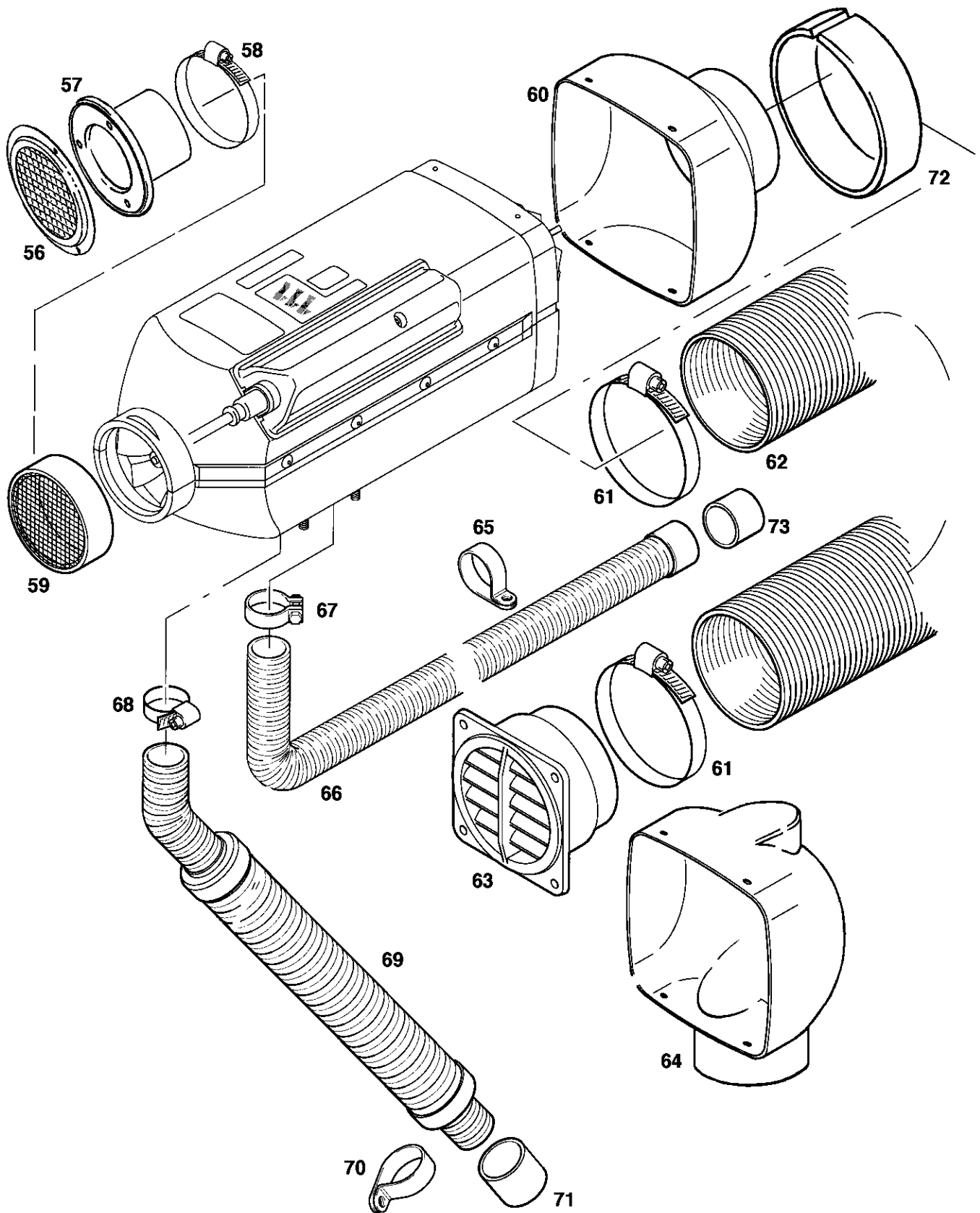

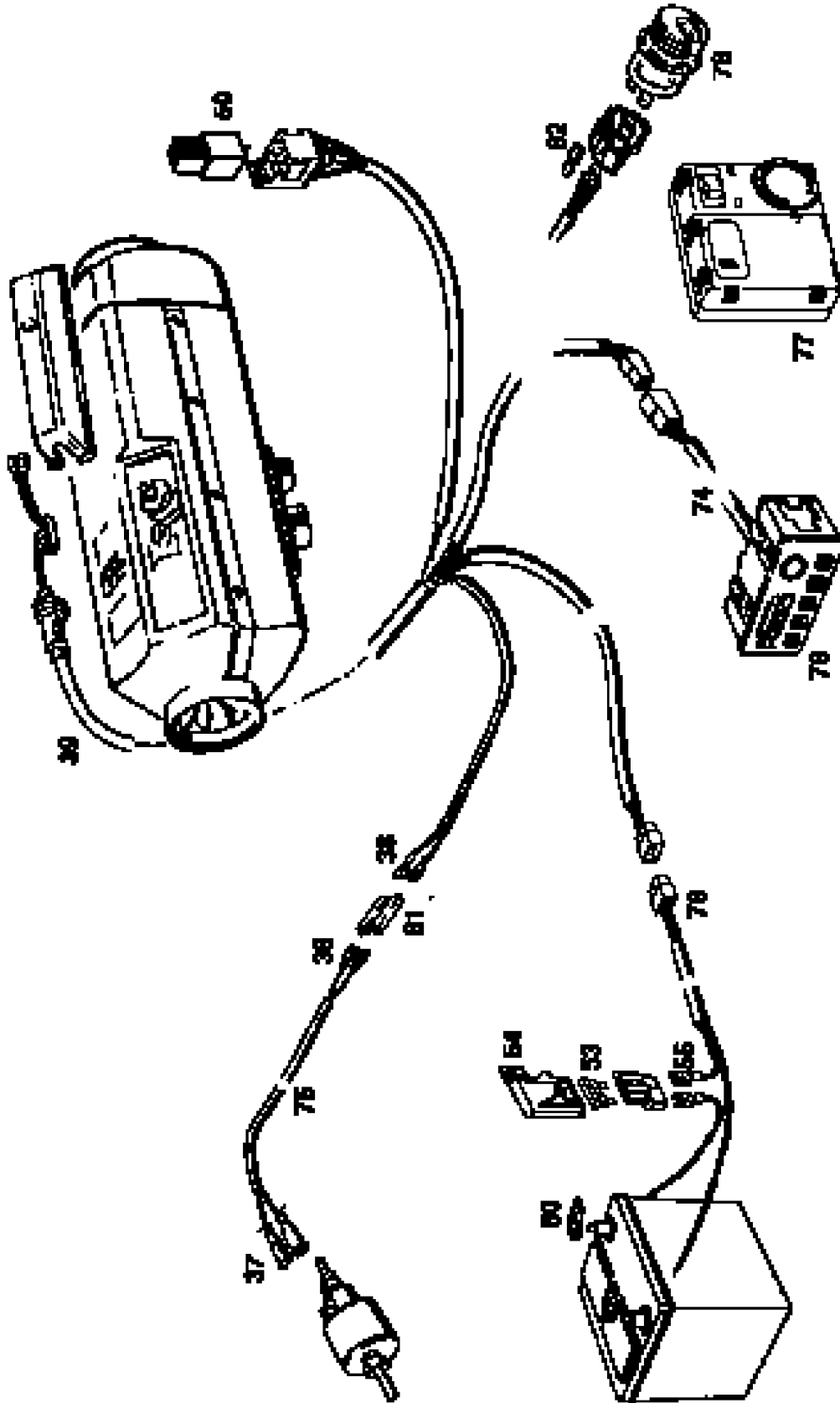

Parts List

D3LCcompact

Heater model

Ref.No.	Description	Part Number	Heater model					
			25 1906	25 1907	25 1967	25 1968	25 1980	25 1981
1	Heat exchanger	25 1882 06 00 00	•	•	•	•	•	•
2	Combustion air blower	12 Volt 25 1906 99 20 00	•	•	•	•	•	•
		24 Volt 25 1907 99 20 00		•		•		•
3	Flame sensor	25 1895 99 35 00	•	•	•	•	•	•
4	Safety thermal sensor *includes cable section	25 1895 41 00 00	•	•	•	•	•	•
5	Lower half of casing	25 1822 01 01 00	•	•	•	•	•	•
6	Upper half of casing	25 1906 01 06 00	•	•	•	•	•	•
7	Control unit	12 Volt 25 1895 50 00 03	•		•			
		24 Volt 25 1896 50 00 02		•		•		
		12 Volt 25 1976 51 00 03					•	
		24 Volt 25 1977 51 00 02						•
* If replacing the control unit on heater models 25 1906 and 25 1967 to the latest control unit 12 Volt 25 1976 51 00 03 you must replace the main heater harness with the p/n. CA1 60 120 harness or follow the conversion instructions provided with the control unit to modify the existing harness								
* If replacing the control unit on heater models 25 1907 and 25 1968 to the latest control unit 24 Volt 25 1977 51 00 02 you must replace the main heater harness with the p/n. CA1 60 120 harness or follow the conversion instructions provided with the control unit to modify the existing harness								
8	Flange seal	25 1822 01 00 02	•	•	•	•	•	•
9	Cable cover	25 1895 01 02 00	•	•	•	•	•	•
10	Glow plug	12 Volt 25 1830 01 01 00	•		•		•	
		24 Volt 25 1831 01 01 00		•		•		•
11	Seal ring	25 1830 01 01 01	•	•	•	•	•	•
12	Glow plug screen	25 1822 06 04 00	•	•	•	•	•	•
13	Gasket, blower	25 1822 01 00 03	•	•	•	•	•	•
14	Gasket, heat exchanger	25 1822 06 00 02	•	•	•	•	•	•
15	Seal ring, heat exchanger	25 1862 06 00 03	•	•	•	•	•	•
16	Spring, flame sensor	25 1895 01 00 03	•	•	•	•	•	•
17	Clip	171 42 082	•	•	•	•	•	•
18	Heater bracket	25 1822 01 00 04	•	•	•	•	•	•
19	Grub screw M6x20 DIN 835	106 10 022	•	•	•	•	•	•
20	Fillister head bolt M5x20	103 10 461	•	•	•	•	•	•
21	U-Clip	25 1688 01 00 03	•	•	•	•	•	•
22	Rivet, black plastic	131 31 051	•	•	•	•	•	•
23	Fillister head bolt M3x10	25 1822 01 00 05	•	•	•	•	•	•
24	Gasket	25 1822 80 09 01	•	•	•	•		
25	Cable connection	25 1895 01 03 00	•	•	•	•		
26	Tapit Screw M5x16	109 00 044	•	•	•	•	•	•
27	Mounting plate with hardware & seal	CA0 00 019	•	•	•	•	•	•
28	Angle bracket	20 1348 03 00 02	•	•	•	•	•	•
29	Rubber mount	20 1673 80 01 01	•	•	•	•	•	•
29a	Rubber mount 6mm	20 1185 00 00 01	•	•	•	•	•	•
30	Clamp for fuel metering pump	152 00 144	•	•	•	•	•	•
31	Plastic fuel line 1.5mm ID	090 31 118	•	•	•	•	•	•



Heater model

Ref.No.	Description	Part Number	Heater model					
			25 1906	25 1907	25 1967	25 1968	25 1980	25 1981
31a	Fuel hose	360 75 300	•	•	•	•	•	•
32	Fuel hose	360 75 350	•	•	•	•	•	•
33	Plastic fuel line 2mm ID	090 31 125	•	•	•	•	•	•
34	Fuel metering pump	25 1830 45 00 00 25 1831 45 00 00	•	•	•	•	•	•
35	Fuel screen	20 1312 00 00 06	•	•	•	•	•	•
36	Hose connection	20 1621 45 00 00	•	•	•	•	•	•
37	Rubber boots	320 31 120	•	•	•	•	•	•
38	Terminals 18 AWG - fuel metering pump	CA1 90 060	•	•	•	•	•	•
39	Main Harness	CA1 60 105 CA1 60 107 CA1 60 120	•	•	•	•	•	•
*40	Fuel pick up pipe (Compression fitting type)	CA0 12 042	•	•	•	•	•	•
*41	Compression fittings 1/4" NPT	CA0 12 044	•	•	•	•	•	•
	3/8" NPT	CA0 00 031	•	•	•	•	•	•
	1/2" NPT	CA0 12 005	•	•	•	•	•	•
42	Standard fuel pick up pipe 2mm	CA0 12 056	•	•	•	•	•	•
43	Flat plug connector	CA1 90 006	•	•	•	•	•	•
44	Connector housing	206 31 009	•	•	•	•	•	•
45	Socket housing	206 31 301	•	•	•	•	•	•
46	Socket connections	206 52 120	•	•	•	•	•	•
47	Grommet	20 1280 09 01 03	•	•	•	•	•	•
48	Tie clips 197mm	CA1 00 005	•	•	•	•	•	•
49	"C" Clamp 10mm	152 00 139	•	•	•	•	•	•
50	Current regulator	25 1966 30 01 00 25 1830 30 01 00	•	•	•	•	•	•
51	Clamp 9mm	10 2063 00 90 98	•	•	•	•	•	•
52	Clamp 11mm	10 2063 01 10 98	•	•	•	•	•	•
53	Blade Fuse (25amp)	204 00 089	•	•	•	•	•	•
54	Fuse holder with terminals	CA1 07 001	•	•	•	•	•	•
55	Terminals	CA1 90 043	•	•	•	•	•	•
*56	Plastic Screen 75mm	25 1729 89 00 05	•	•	•	•	•	•
*57	Flange for outlet grill	25 1226 89 00 12	•	•	•	•	•	•
*58	Clamp 52mm-82mm	CA1 10 041	•	•	•	•	•	•
59	Safety screen 75mm	25 1552 05 01 00	•	•	•	•	•	•
60	Outlet hood 75mm	25 1822 80 01 00	•	•	•	•	•	•
61	Clamp 3 inch(75mm)	CA1 10 041	•	•	•	•	•	•
	Clamp 4 inch(100mm)	CA1 10 042	•	•	•	•	•	•
62	Flexible air hose 75mm	10 2114 34 00 00	•	•	•	•	•	•
63	Deflector 75/100mm	22 1050 89 21 00	•	•	•	•	•	•
*64	90° Air outlet hood	22 1000 01 00 03	•	•	•	•	•	•
65	C clamp	152 10 051	•	•	•	•	•	•
66	Flexible exhaust hose	25 1774 80 01 00	•	•	•	•	•	•

Ref.No.	Description	Part Number	Heater model					
			25 1906	25 1907	25 1967	25 1968	25 1980	25 1981
67	Clamp 26mm	152 61 102	•	•	•	•	•	•
68	Clamp	10 2064 02 00 32	•	•	•	•	•	•
69	Air intake silencer	20 1451 01 01 00	•	•	•	•	•	•
70	C clamp	152 10 047	•	•	•	•	•	•
71	End sleeve with cross bar	25 1729 89 00 02	•	•	•	•	•	•
*72	Fibre ring adapter 90mm- 4" (Wooden)	CA2 02 002	•	•	•	•	•	•
	90-100mm (Plastic)	20 1602 80 00 01	•	•	•	•	•	•
73	End sleeve with cross bar	25 1729 80 06 00	•	•	•	•	•	•
74	Switch/ Thermostat harness (15')	CA1 70 111	•	•	•	•	•	•
75	Fuel metering pump harness (20')	CA1 75 015	•	•	•	•	•	•
76	Power harness (13')	CA1 65 106	•	•	•	•	•	•
77	Thermostat	12 Volt 301 00 154	•		•		•	
		24 Volt 301 00 153		•		•		•
*78	Operating switch (rotary)	12 Volt 25 1895 71 00 00	•		•		•	
		24 Volt 25 1896 71 00 00		•		•		•
*79	7 day timer	22 1000 30 40 00	•	•	•	•	•	•
80	3/8" Ring terminal 10-12G	CA1 90 014	•	•	•	•	•	•
81	Plug and socket connector	206 00 040	•	•	•	•	•	•
82	Terminals	CA1 900 21	•	•	•	•	•	•
83	D3LCc North American manual (not shown)	610 102 1298	•	•	•	•	•	•
*84	Fault code retrieval device (shown pg. 20)	CA1 05 020	•	•	•	•	•	•
*	indicates optional features							

1st. Printing - November 1998

Printed in Canada

P/N: 610-102-1298



www.espar.com
inquiries@espar.com

Espar Products, Inc.

6435 Kestrel Road
Mississauga, Ontario
Canada L5T 1Z8

17672 N. Laurel Park Drive
Suite 400E
Livonia, Michigan
United States
48152-3984

Canada (Tel):	905-670-0960
	800-668-5676
Fax:	905-670-0728
U.S. (Tel):	800-387-4800