

Scope of Application

- Heating truck sleeper cab
- Heating crane cab
- Heating van or minibus interior
- Heating motorhomes
- Heating boats up to 10 metres – special installation kits available

Product Advantages

- A very compact design with integral ECU and simple rheostat control for easy operation
- Standard industry footprint – floorplates available
- Low current consumption
- Glow pin technology
- Very low fuel consumption with vari-heat technology
- Self-diagnostic function via flashing light on control panel
- Remote control available
- Telephone SMS module available



Working Principle

The heater uses the diesel direct from the vehicle fuel tank via its own fuel pump to provide hot air to the interior of the vehicle.

The products of combustion are exhausted externally via the heater's own exhaust system underneath the vehicle.

The heater controls are simple and fully automatic giving a controlled variable output from 0.9kw - 2.0kw. Powerful, quiet and economical, the MV Airo 2kw is a masterpiece of engineering to give you years of low cost, clean blown air heat whilst stationary or on the move.

Technical Specification:

Thermal Power	0.9 - 2.0kw	
Fuel	Petrol	Diesel
Rated Voltage	12 / 24V	12 / 24V
Fuel Consumption (l/h)	0.14 - 0.27	0.12 - 0.24
Rated Power	14 - 29	
Lowest Working Temp	-40°C – +20°C	
Weight (kg)	2.6	
Dimensions	323 x 120 x 121	



Standard – Rheostat Control

The standard control for easy operation and heat regulation. Has built-in LED for diagnostics function.



Mobile Phone – Remote Control

SMS Control: put a SIM card in and send the heater a text to switch on and off from anywhere in the world. You will receive a reply to say 'on' or 'off'. Brilliant and simple! Note: you will need to provide a SIM card.



Remote Control

Fix it to your key fob – simple operation; the remote has 3 keys: 15 mins, 30 mins and 45 mins – press one button to run the heater for this period of time. The display on the remote control has a time remaining indicator. Works up to a distance of 500m with no obstacles.

Dimensions:

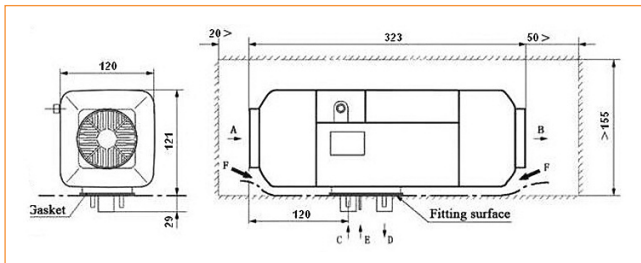

Parts:

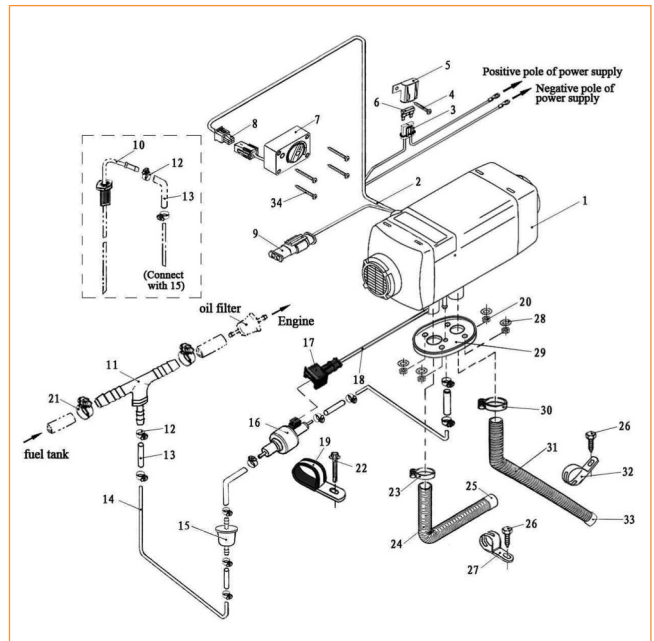

MV Heating (UK) Limited

Unit 6 & 7, Second Avenue Business Park, Millbrook, Southampton, Hants SO15 0LP
Telephone: 023 8052 2345 Fax: 023 8052 8808 Email: sales@mvheating.com

www.mvheating.com